

12/30/2011 11:47:44 AM rd960rh C:\projects\standards\structures\current\ready\release\2012book_draft\06100-1of2.dgn

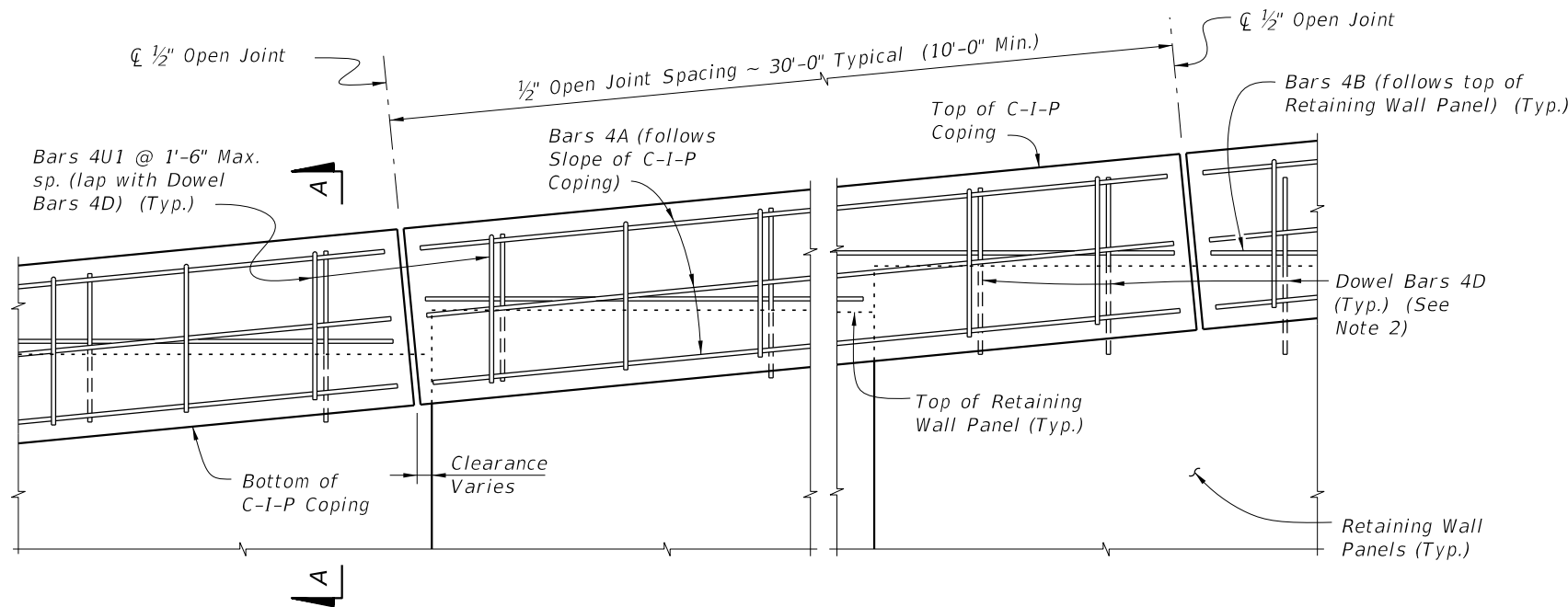

C-I-P COPING - PARTIAL ELEVATION VIEW

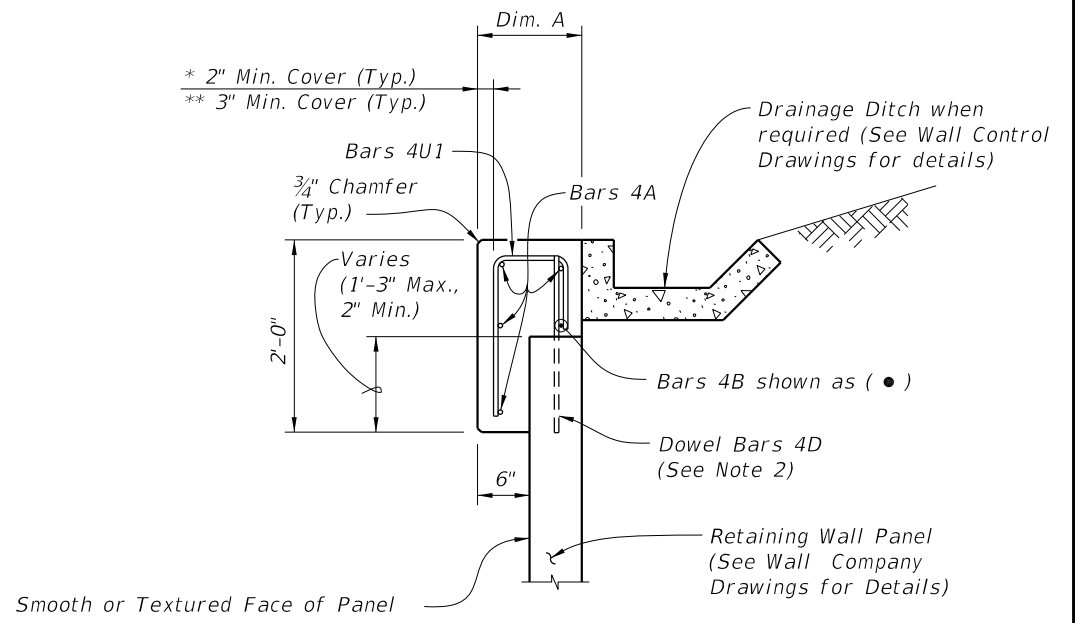

SECTION A-A C-I-P COPING

Dim. A	Panel width + 6"
Dim. B	Panel width + 1'-0" Min.

- PRECAST AND C-I-P COPING NOTES:**
1. Provide Class II concrete for slightly aggressive environments or Class IV for moderately or extremely aggressive environments.
 2. Dowel Bars 4D extend 1'-0" above the top of retaining wall panel. Field cut as necessary to maintain 2" minimum cover. See Wall Company Drawings for number and spacing of Dowel Bars 4D.
 3. Payment for Dowel Bars 4D, Buildup Concrete and Coping will be made under Retaining Wall System (Permanent).

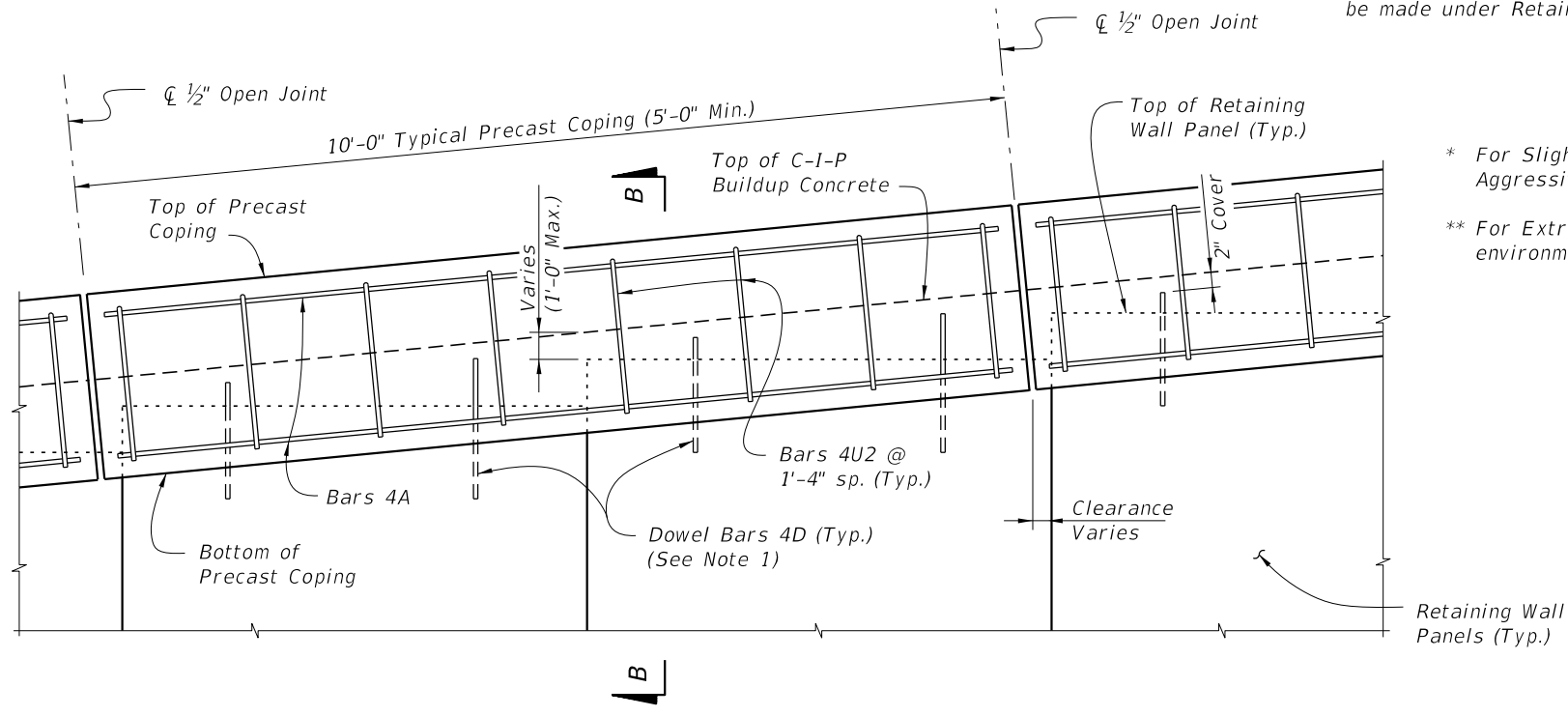

PRECAST COPING - PARTIAL ELEVATION VIEW

- * For Slightly and Moderately Aggressive environments
- ** For Extremely Aggressive environments.

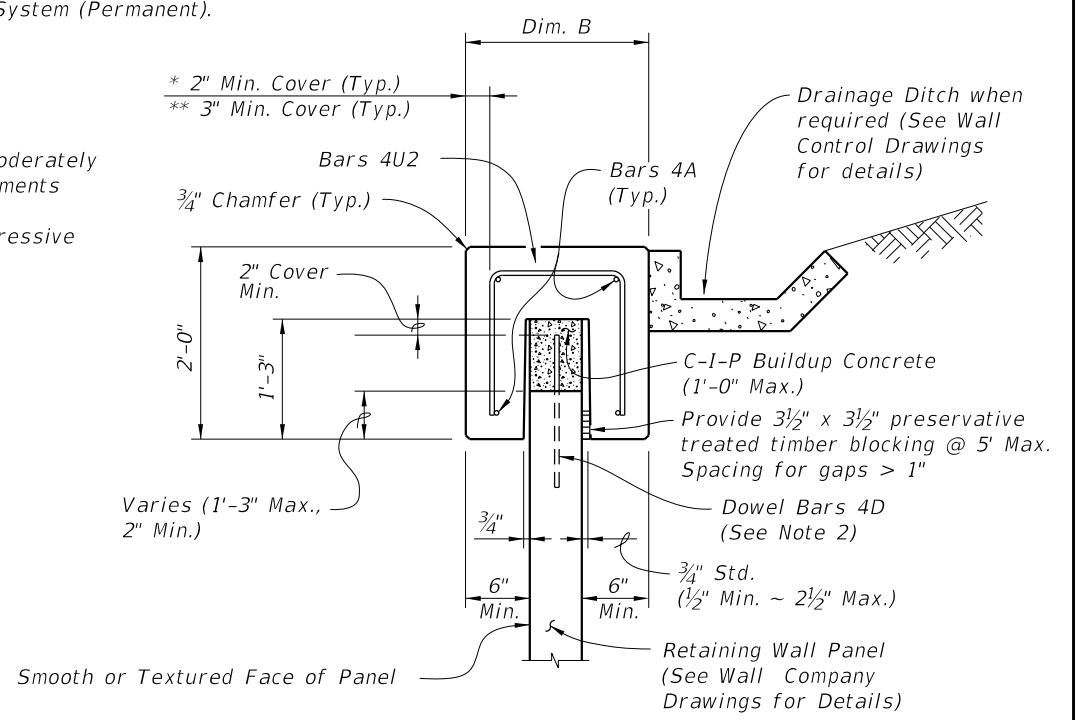

SECTION B-B PRECAST COPING

LAST REVISION	01/01/12	DESCRIPTION:		FDOT DESIGN STANDARDS FY 2012/2013	MSE WALL COPING (PRECAST OR C-I-P)	INDEX NO.	6100	SHEET NO.	1
---------------	----------	--------------	---------------------------------------------------------------------------------------	-----------------------------------------------------	-------------------------------------------	-----------	------	-----------	---

REINFORCING STEEL BENDING DIAGRAMS - PRECAST AND C-I-P COPINGS

BILL OF REINFORCING STEEL

MARK	SIZE	LENGTH * S or M	LENGTH * E
A	4	AS REQD.	AS REQD.
B	4	AS REQD.	AS REQD.
D	4	2'-0"	2'-0"
U1	4	Panel width + 4"	Panel width + 3"
U2	4	Panel width + 8"	Panel width + 6"
U3	4	Panel width + 4"	Panel width + 3"

REINFORCING STEEL NOTES:

- All bar dimensions in the bending diagrams are out to out.
- All reinforcing steel at the open joints will have a 2" minimum cover.
- Bars 4A may be continuous or spliced at the construction joints. Lap splices for Bars 4A will be a minimum of 1'-8".
- The Contractor may use Welded Wire Reinforcement when approved by the Engineer. Welded Wire Reinforcement will conform to ASTM A 497.

* S = Slightly Aggressive
 M = Moderately Aggressive
 E = Extremely Aggressive

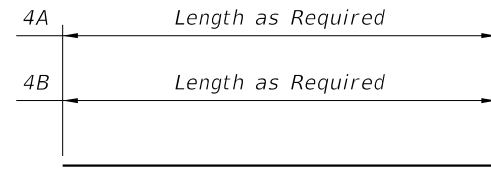

BARS 4A & 4B

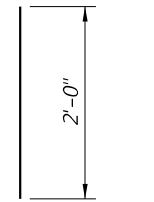

DOWEL BAR 4D

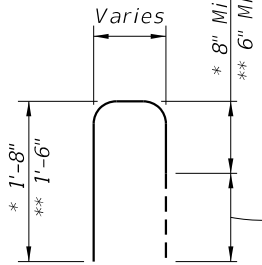

BAR 4U1

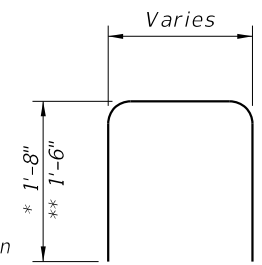

BAR 4U2

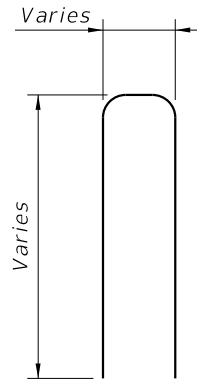

BAR 4U3

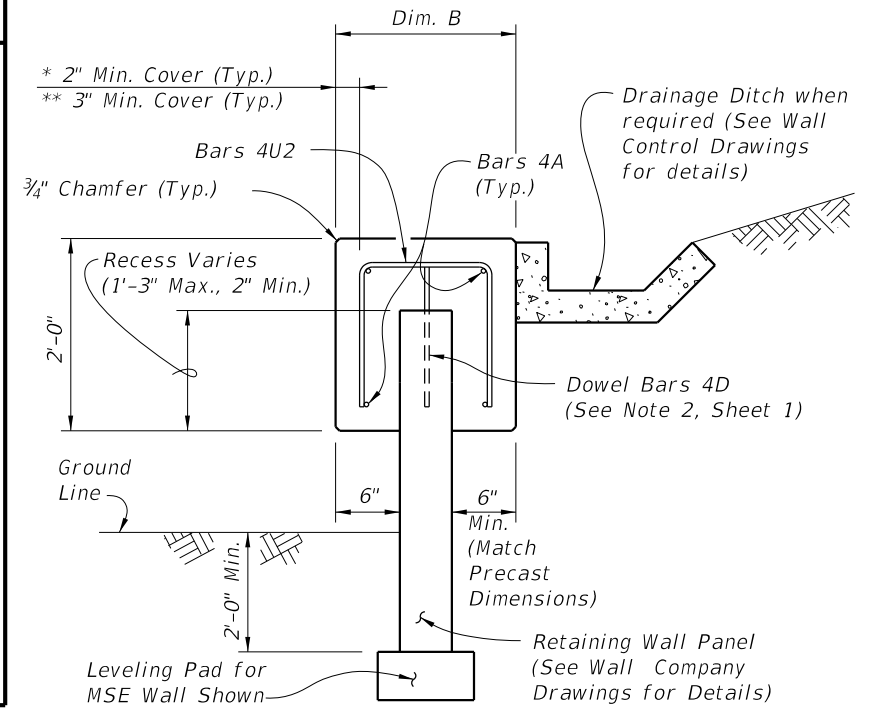

C-I-P COPING USED WITH PRECAST COPING

Note: When precast coping units do not fit the entire length of the retaining wall, use this similar C-I-P coping for short portions between precast coping units. This C-I-P coping may also be used for vertical copings.

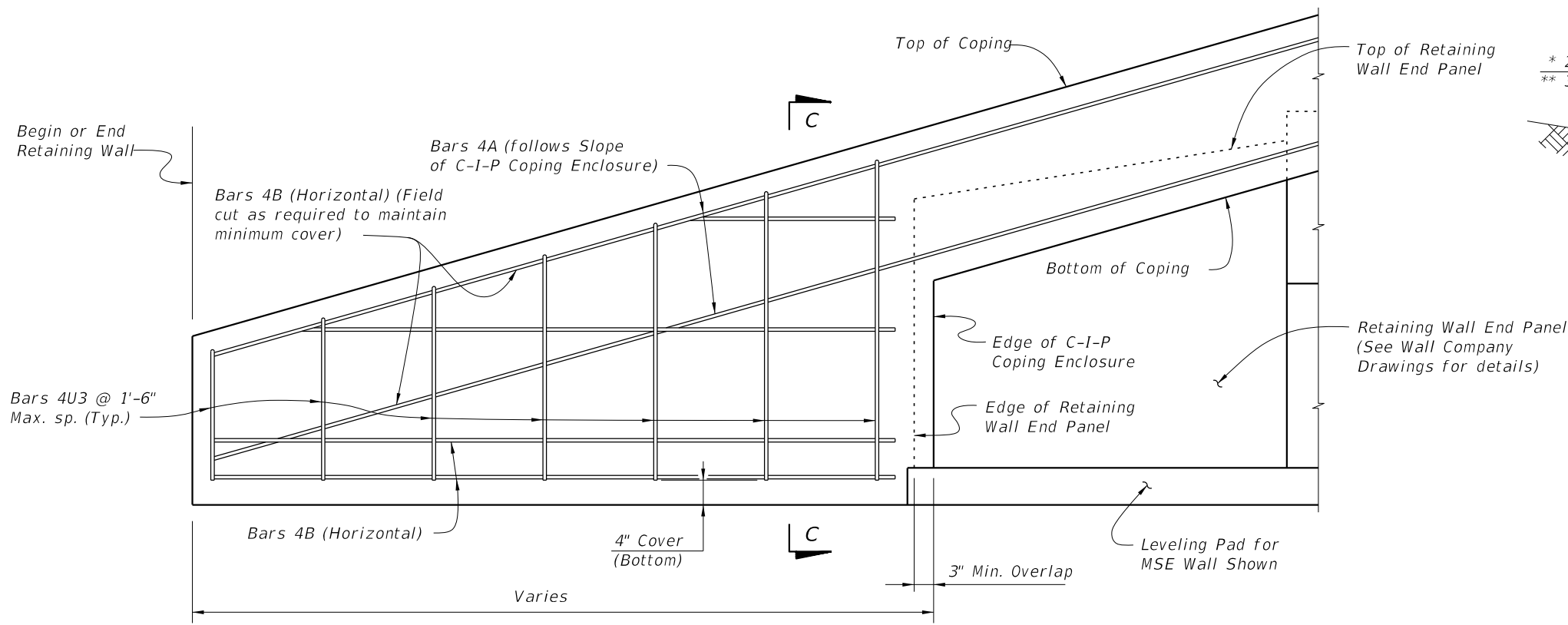

C-I-P COPING ENCLOSURE DETAIL

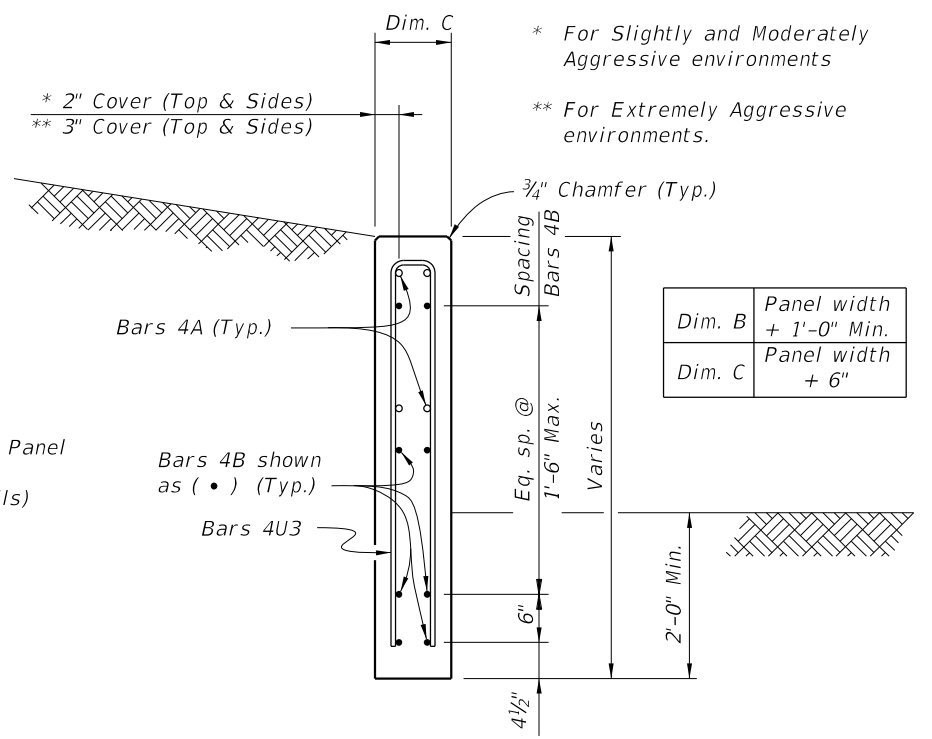

SECTION C-C

C:\projects\standards\structures\current\ready\4release\2012book_draft\06100-2of2.dgn
 rd960/h
 11:47:44 AM
 12/30/2011