

NOTES

SPECIFICATIONS:

1. General Specifications:
The Florida Department of Transportation "Standard Specifications for Road and Bridge Construction", Current Edition and Supplements as Amended.
2. Design Specifications:
 - a. Florida Department of Transportation (FDOT) "Structures Design Guidelines", Current Edition.
 - b. American Association of State Highway and Transportation Officials (AASHTO) "LRFD Bridge Design Specifications", Current Edition.
 - c. AASHTO-AGC-ARTBA Task Force 27 (Ground Modification Techniques), "Insitu Soil Improvement Techniques", January 1990.

DESIGN CRITERIA:

1. Design is based on the assumption that the material contained within the reinforced soil volume, methods of construction and quality of prefabricated materials are in accordance with Specification Section 548 and FDOT Structures Design Guidelines Section 3.13.2.
2. It is the responsibility of the Engineer to determine that the factored bearing pressure shown for the wall does not exceed the factored bearing resistance of the foundation for that specific wall location.
3. The Wall Company is responsible for internal stability of the wall. External stability design, including foundation and slope stability, is the responsibility of the Engineer.
4. If present, consider in design and analysis and locate manholes and drop inlets as shown on wall elevations.

SOIL PARAMETERS:

1. See wall control drawings for soil characteristics of foundation material to be used in the design of the wall system. The Contractor must provide soil design parameters for backfill material based on the actual soil characteristics utilized at the site. Provide the values of unit weight, cohesion and internal friction angle in the Shop Drawings.

MATERIALS:

1. Provide soil reinforcement in accordance with Specification Section 548.
2. For additional material notes, see Wall Company General Notes.

CONSTRUCTION:

1. Walls must be constructed in accordance with Specification Section 548 and the Wall Company's instructions.
2. For location and alignment of retaining walls, see Wall Control Drawings.
3. Refer to Plan and Elevation sheets of individual walls for minimum reinforcement strip/mesh length, factored bearing resistance's, minimum wall embedment and anticipated long term and differential settlements.
4. If existing or future structures, pipes, foundations or guardrail posts within the reinforced soil volume interfere with the normal placement of soil reinforcement and specific directions have not been provided on the plans, the Contractor must notify the Engineer to determine what course of action should be taken.
5. The Contractor is responsible for gradually deflecting upper layer(s) of soil reinforcement downward (15° maximum from horizontal) to avoid cutting soil reinforcement and conflicts with paving and subgrade preparation. The Contractor's attention is directed especially to situations where roadway superelevation and/or soil mixing are anticipated.

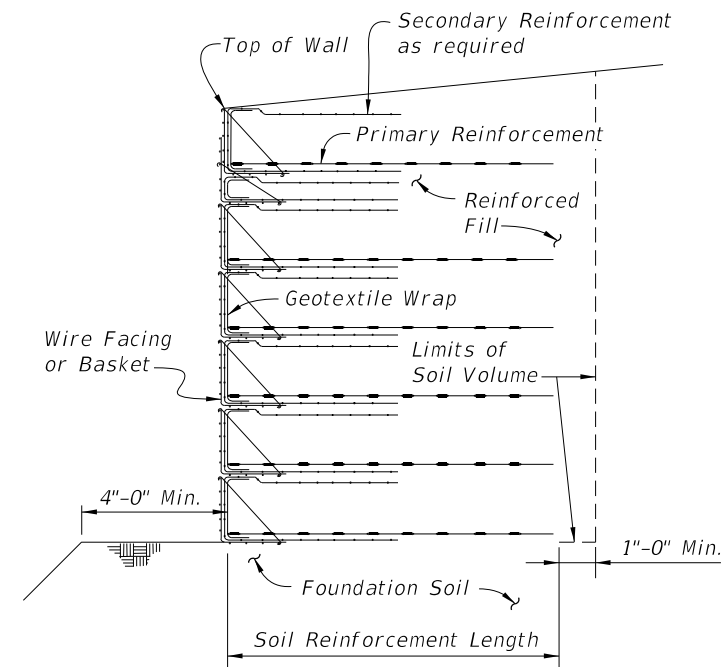

**TYPICAL RETAINING WALL SECTION
(Showing Limits of the Reinforced Soil Volume)**

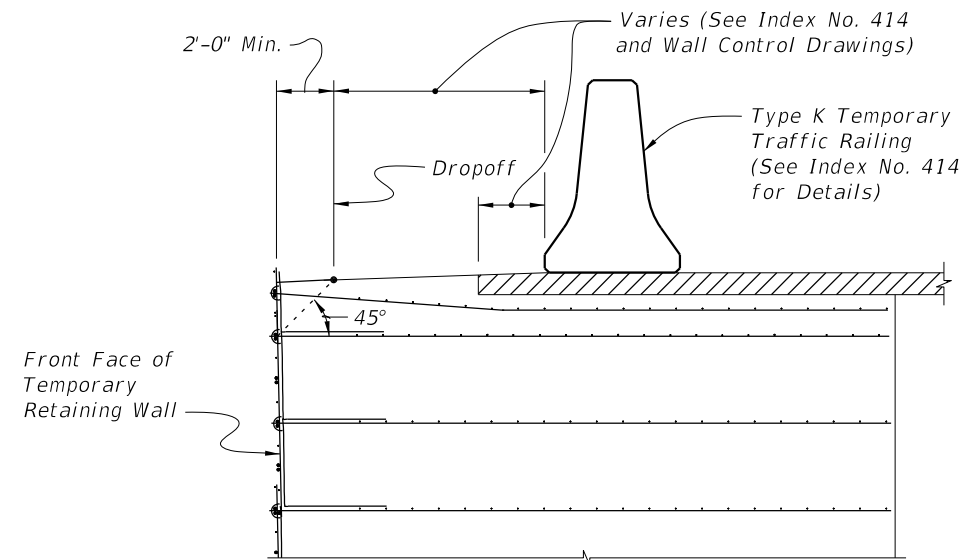

**TEMPORARY TRAFFIC RAILING
PLACEMENT DETAIL**

GENERAL NOTES AND DETAILS

C:\projects\standards\structures\current\ready\4release\2012book_draft\06030-1of1.dgn 12/30/2011 11:47:39 AM rd960rh

LAST REVISION	01/01/11	DESCRIPTION:	 FDOT DESIGN STANDARDS FY 2012/2013	TEMPORARY MSE RETAINING WALL SYSTEMS	INDEX NO.	SHEET NO.
					6030	1