

C:\projects\standards\structures\current\read\4release\2012book_draft\06011-1of1.dgn 11:47:36 AM r0960rh 12/30/2011

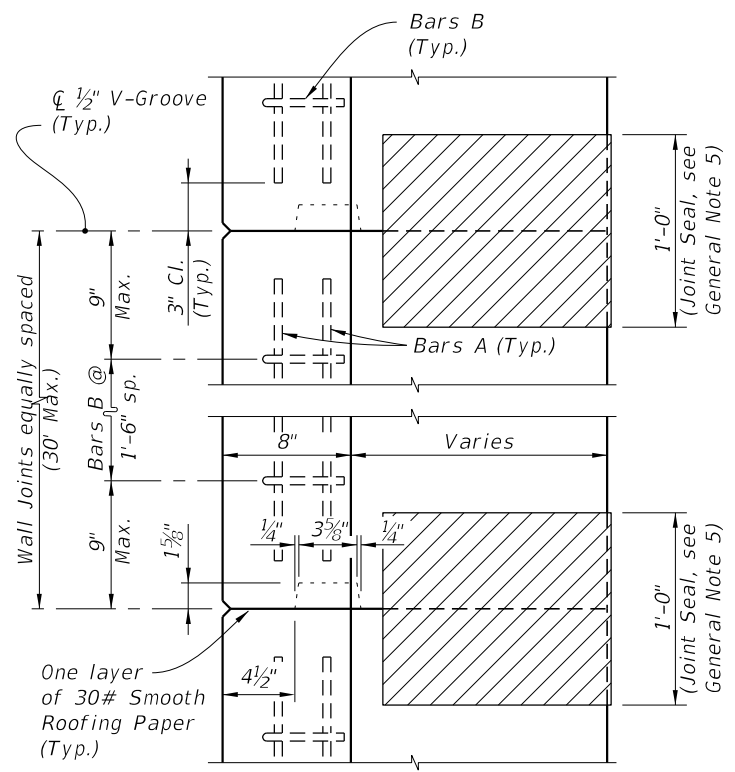

KEYWAY & WALL JOINT DETAIL (TOP VIEW)

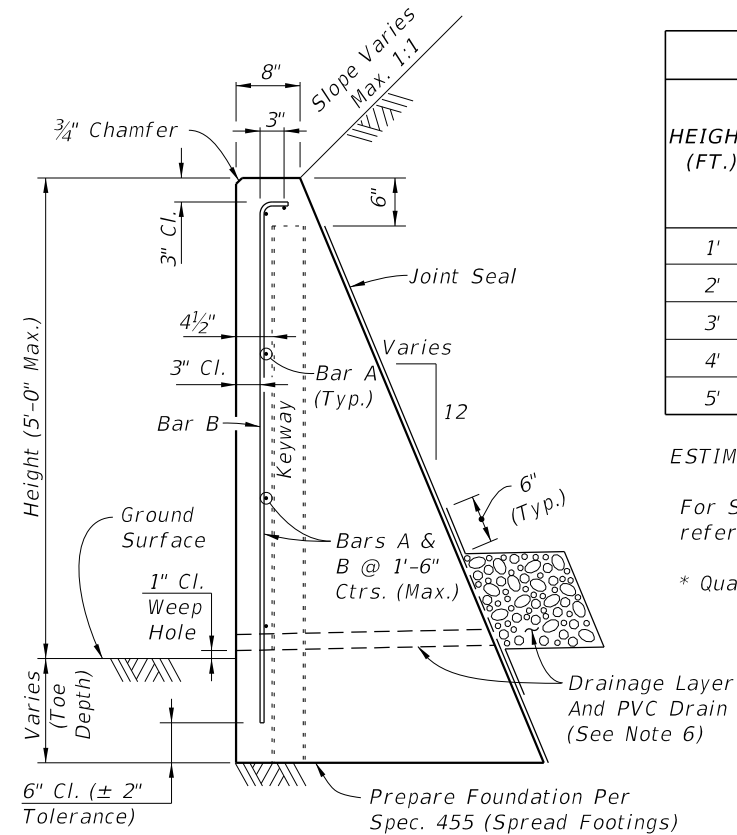

TYPICAL SECTION

HEIGHT (FT.)	PER LINEAR FOOT OF WALL			REINF. STEEL (LB.)	WEEP HOLES & DRAIN REEQD.
	CLASS NS CONCRETE (CY)				
	SCHEME 1	SCHEME 2	SCHEME 3		
1'	0.08	0.11 (0.20*)	0.03	3 (4*)	No
2'	0.14	0.20 (0.32*)	0.09	4 (5*)	No
3'	0.22	0.32 (0.47*)	0.29	5 (6*)	Yes
4'	0.32	0.47 (0.65*)	0.43	6 (7*)	Yes
5'	0.43	0.65 (0.85*)	0.60	7 (8*)	Yes

ESTIMATED QUANTITIES NOTES:

For Scheme 3 Junction Slab and Traffic Railing see the referenced Design Standards for estimated quantities.

* Quantity for 2'-0" Toe Depth in Scheme 2.

GENERAL NOTES

- Gravity walls constructed as extensions of reinforced concrete retaining walls, except walls of proprietary designs, shall have the same face texture and finish as the reinforced concrete retaining wall.
- Concrete for Gravity Wall shall be Class NS per Section 347. Concrete for Scheme 3 Junction Slab and Traffic Railing shall be Class II per Section 346, unless otherwise specified in the plans.
- Reinforcing steel shall be ASTM A615, Grade 40 or 60 provided at the max. spacings shown. ASTM A185 Smooth or ASTM A497 Deformed Welded Wire Reinforcement (WWR) may be substituted on an equal area basis. Do not increase bar/wire spacing for Grade 60 reinforcing steel or WWR.
- When required, for adjunct guiderail see the plans, Index No. 870 or 880 as appropriate. For adjunct Type B fence see Index No. 802.
- Joint seal to be two layers of 30# smooth roofing paper or Type D-5 geotextile fabric in accordance with Index No. 199. Mop all contact surfaces of concrete and roofing paper or geotextile fabric with cut-back asphalt. Stop roofing paper or geotextile fabric 6" below top of wall.
- Provide a continuous 1'x1' clean gravel or crushed rock drain for wall heights 3 ft. and higher. Wrap drainage layer as shown, with Type D-3 geotextile fabric in accordance with Index No. 199. Provide 8"x8" galvanized mesh with 1/4" openings, at the inside end of the PVC Drain Pipe. Provide 2" Ø PVC Drain Pipe (Sch. 40) at 10 ft. max. spacing (When Drainage Layer required). Locate minimum 2'-0" clear of wall joints.
- Cost of reinforcing steel, face texture, finish, joint seal, drain pipes, drainage layer, galvanized mesh and geotextile fabric to be included in the Contract Unit Price for Concrete Class NS, Gravity Wall. Cost of concrete for Junction Slab in Scheme 3, to be included in Contract Unit Price for Concrete Traffic Railing Barrier With Junction Slab. Adjunct railings or fences to be paid for separately.

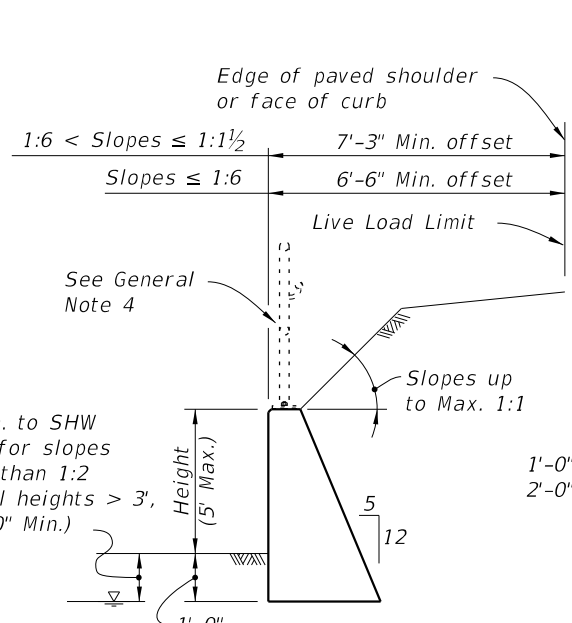

SCHEME 1 (No Traffic Loading Effects)

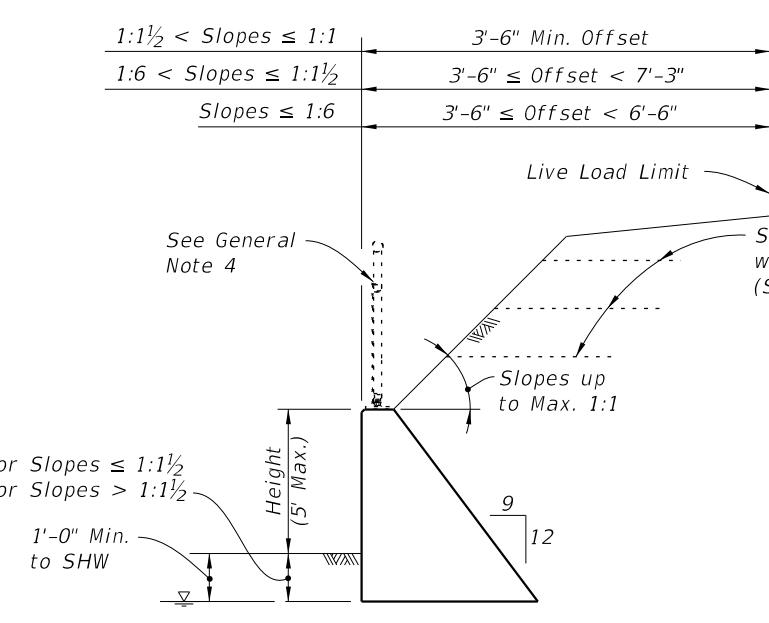

SCHEME 2 (With Traffic Loading or Slopes > 1:1 1/2)

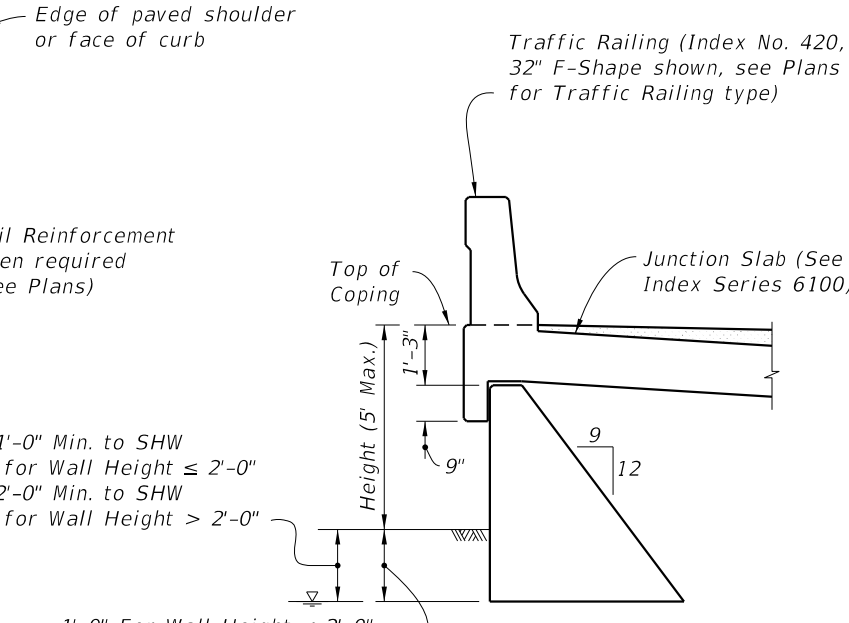

SCHEME 3 (With Traffic Railing)

BILL OF REINFORCING STEEL		
MARK	SIZE	LENGTH
A	4	As Reqd.
B	4	As Reqd.

BAR BENDING DIAGRAM

Bar bending diagram showing dimensions for Bar A and Bar B. Bar A has a wall joint spacing of 4" (29'-8" Max.). Bar B has a height + toe depth of 9" and a height + toe depth of 2'-0".

NOTES:

- All bar dimensions are out to out.
- Lap splices for Bars A must be a minimum of 1'-6".