

METAL OR PLASTIC CAPS FOR DOWEL BARS

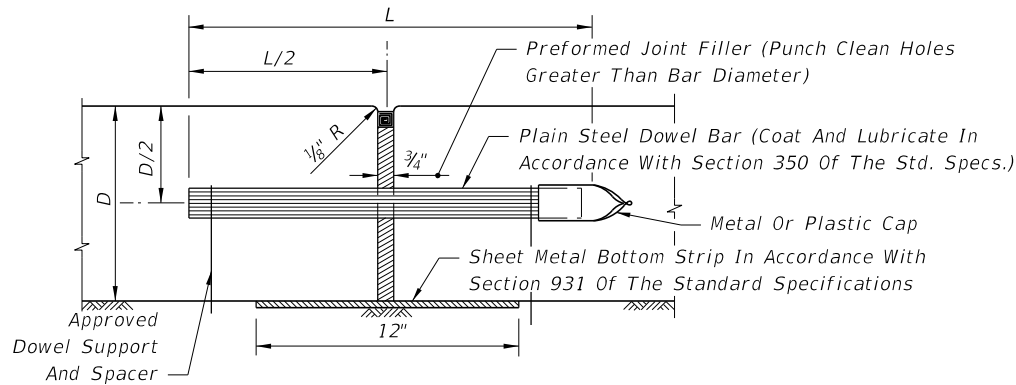

Note: Expansion joints to be placed on approaches to bridges, at street intersections and other locations indicated in detail plans.

TRANSVERSE EXPANSION JOINT

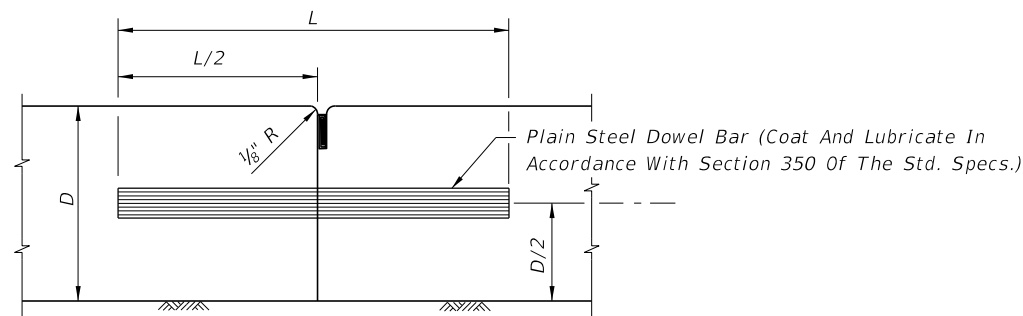

BUTT CONSTRUCTION JOINT TO BE USED AT DISCONTINUANCES OF WORK

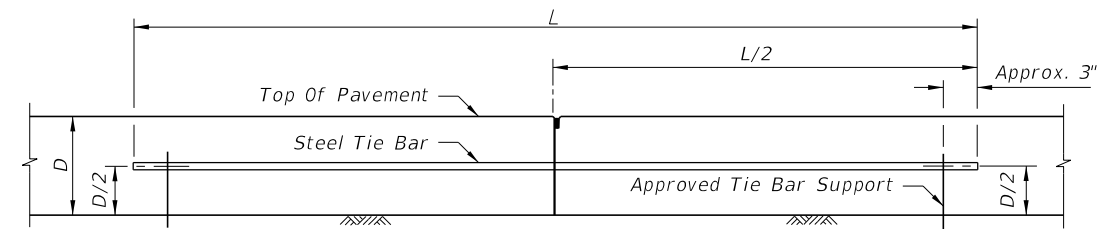

Note: Tie bar spacing shall not exceed 24" at these joints.

LONGITUDINAL BUTT CONSTRUCTION JOINT

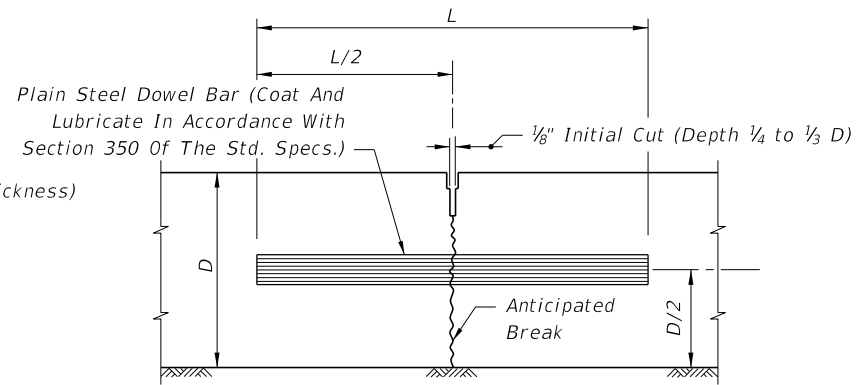
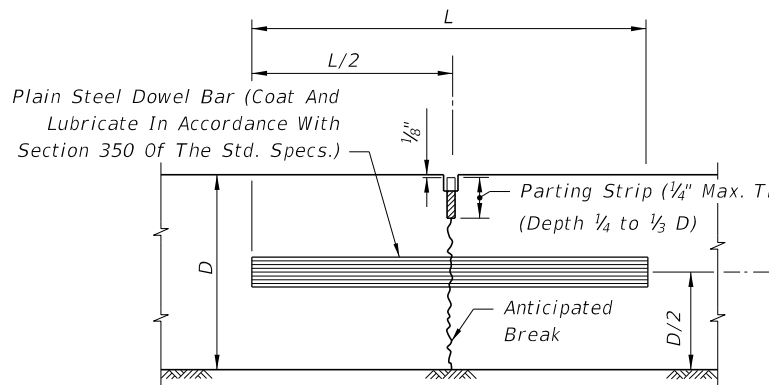

TRANSVERSE CONTRACTION JOINT, VIBRO CAST METHOD TRANSVERSE CONTRACTION JOINT, SAWED METHOD

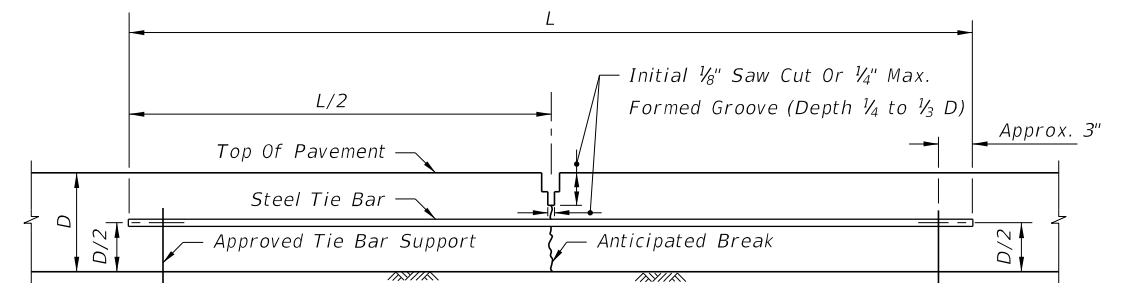

Note: Slabs poured simultaneously. Tie bars may be inserted in the plastic concrete by means approved by the Engineer.

LONGITUDINAL LANE-TIE JOINT

Tie bars are deformed #4 or #5 reinforcing steel bars meeting the requirements of Section 931 of the Standard Specifications.

Provide a standard load transfer tied joint with #4 bars 25" in length at 24" or #5 bars 30" in length at 38" spacing.

LONGITUDINAL JOINTS

Note: For joint seal dimensions see Sheet 2.

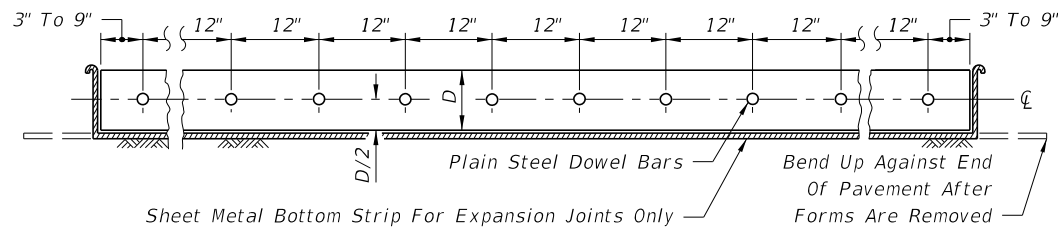

DOWEL BAR LAYOUT

TRANSVERSE JOINTS ARE TO BE SPACED AT A MAXIMUM OF 15'. DOWELS ARE REQUIRED AT ALL TRANSVERSE JOINTS UNLESS OTHERWISE NOTED IN PLANS.

TRANSVERSE JOINTS

DOWELS (LENGTH 18")	
Pavement Thickness "D"	Diameter
6"-6 1/2"	3/4"
7"-8 1/2"	1"
9"-10 1/2"	1 1/4"
≥ 11"	1 1/2"

C:\projects\standards\roadway\0300-s\0305-01.dgn 11:41:05 AM r1960/h 12/30/2011

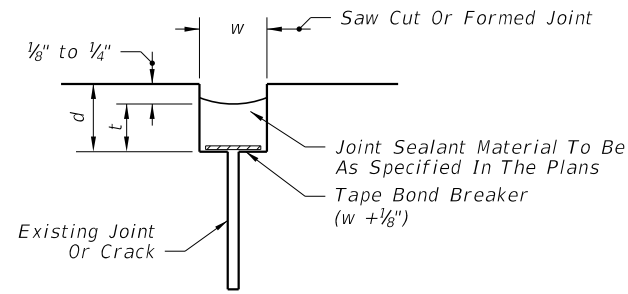

Note: Dimension w will be shown in the plans or established by the Engineer based on field conditions. Dimension d will be constructed so that the shape factor w/t has a maximum value of 2.0 and a minimum value of 1.0.

FOR REHABILITATION PROJECTS
TAPE BOND BREAKER

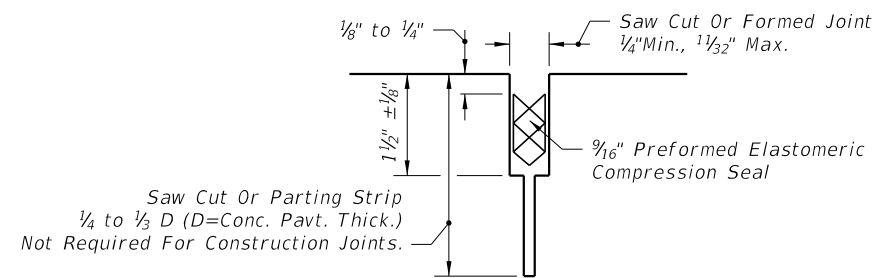

FOR NEW PROJECTS
PREFORMED ELASTOMERIC COMPRESSION SEAL

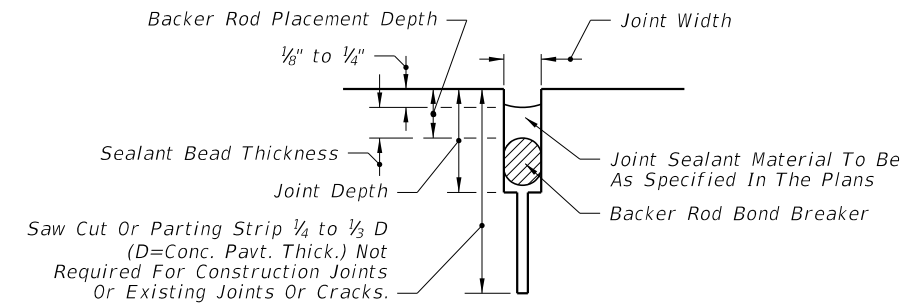

FOR NEW AND REHABILITATION PROJECTS
BACKER ROD BOND BREAKER

CONCRETE-CONCRETE JOINTS

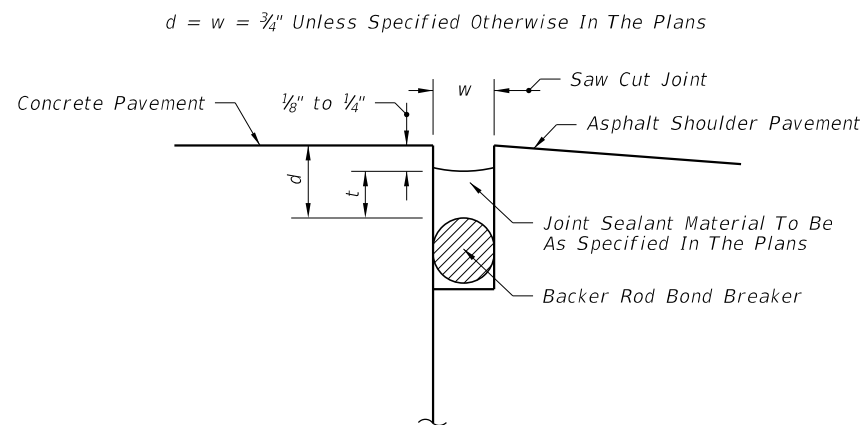

BACKER ROD BOND BREAKER

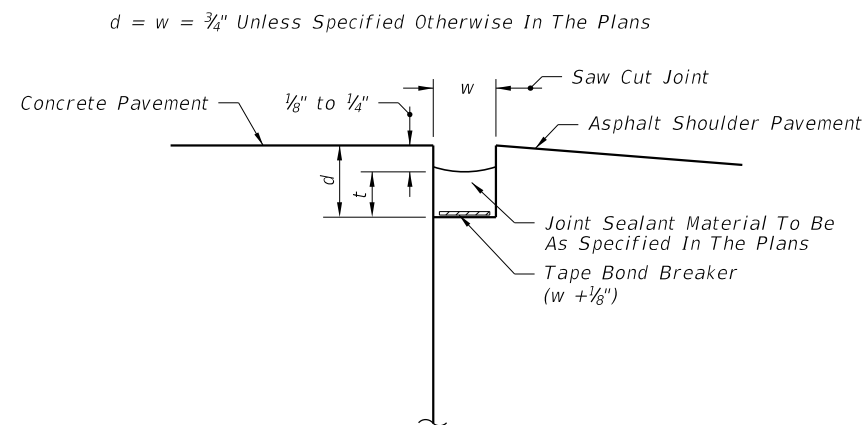

TAPE BOND BREAKER

FOR NEW AND REHABILITATION PROJECTS;
EITHER TAPE OR BACKER ROD BOND BREAKER REQUIRED;
SHOULDER MUST BE REPAIRED IF PROPER JOINT SHAPE
CAN NOT BE ATTAINED

CONCRETE-ASPHALT SHOULDER JOINTS

JOINT SEAL DIMENSIONS

BACKER ROD BOND BREAKER (CONCRETE-CONCRETE JOINTS)

JOINT DIMENSIONS (INCHES)

JOINT WIDTH	SEALANT BEAD THICKNESS	BACKER ROD DIA.	MINIMUM JOINT DEPTH	BACKER ROD PLACEMENT DEPTH
1/4	1/4	3/8	1	1/2
3/8	1/4	1/2	1 1/4	1/2
1/2	1/4	3/8	1 1/4	1/2
3/8	3/16	3/4	1 1/2	3/16
3/4	3/8	1	1 3/4	3/8
7/8	7/16	1 1/8	1 3/4	1 1/16
1	1/2	1 1/4	2	3/4
>1	1/2	1 1/4+	2+	3/4

Unless otherwise indicated on the plans the joint width for new construction will be 1/4" for construction joints, 3/8" for all other joints.

For rehabilitation projects the joint width will be shown on the plans or established by the Engineer based on field conditions.

C:\projects\standards\roadway\03300-s\03305-02.dgn

r1960/h

11:41:06 AM

12/30/2011

LAST REVISION 00	REVISION	DESCRIPTION:	 FDOT DESIGN STANDARDS FY 2012/2013	CONCRETE PAVEMENT JOINTS	INDEX NO. 305	SHEET NO. 2
---------------------	----------	--------------	---	--------------------------	------------------	----------------

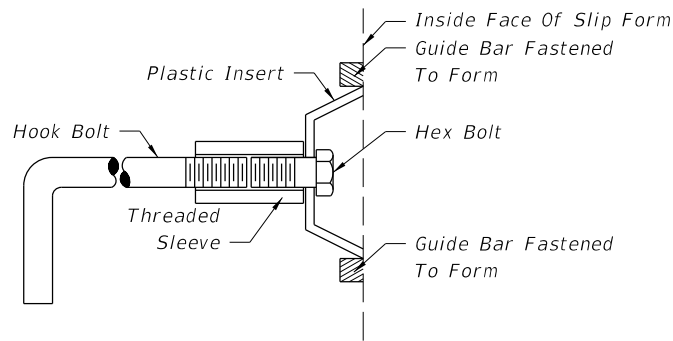

Note: After the concrete has set to the extent that the keyway will retain its shape, the hex bolt and plastic insert shall be removed. The remaining portion of the hook bolt assembly shall be installed immediately prior to placing of concrete in the adjacent lane.

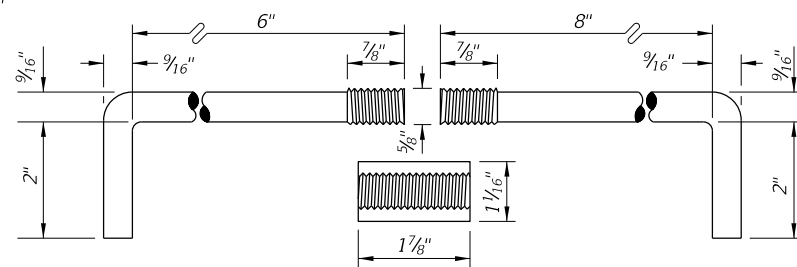

Anchor bolts shall be Grade C in accordance with ASTM A 307.

Threaded sleeves shall develop the full strength of the bolt and meet the material and thread requirements of ASTM A 563.

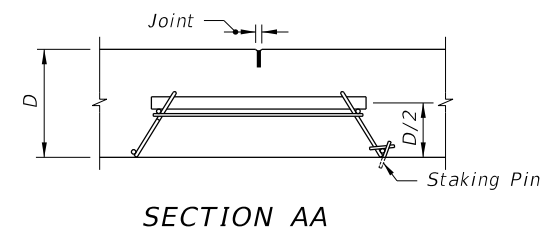

SECTION AA

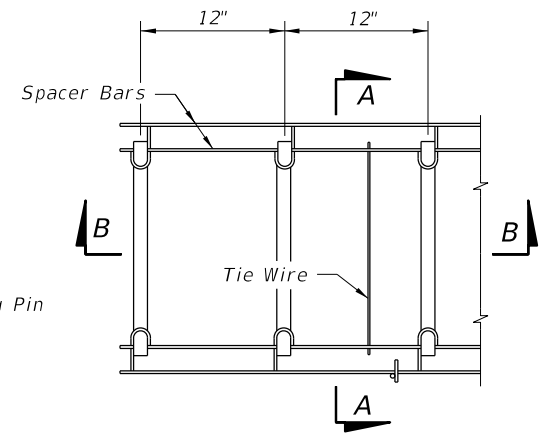

TOP VIEW

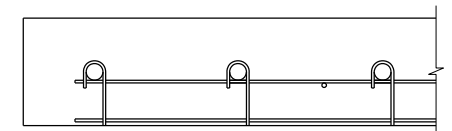

SECTION BB

CONTRACTION ASSEMBLY

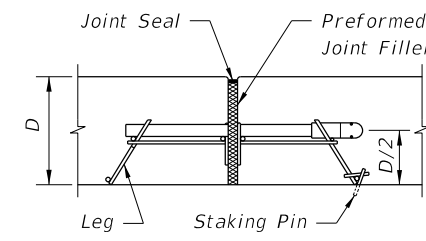

SECTION CC

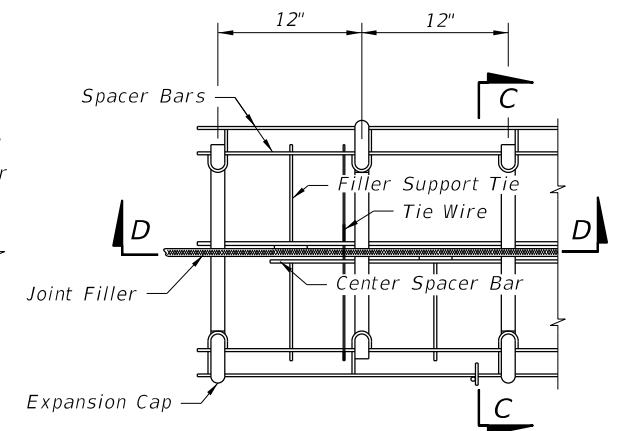

TOP VIEW

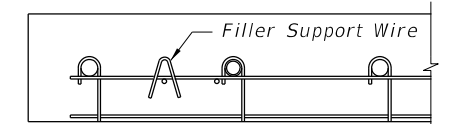

SECTION DD

EXPANSION ASSEMBLY

Note: Proprietary contraction and expansion assemblies may be used. Products shall be introduced to the State Construction Office in accordance with section (C) of the Product Evaluation Procedure.

ALTERNATE KEYWAY AND HOOK BOLT

STEEL HOOK BOLT ASSEMBLY

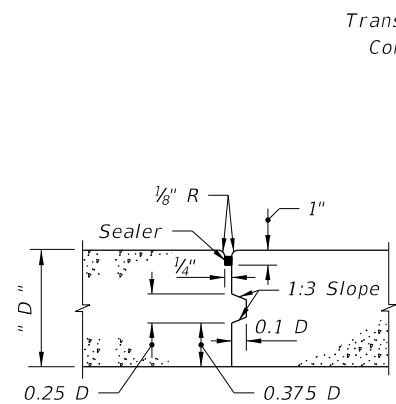

KEYED JOINT

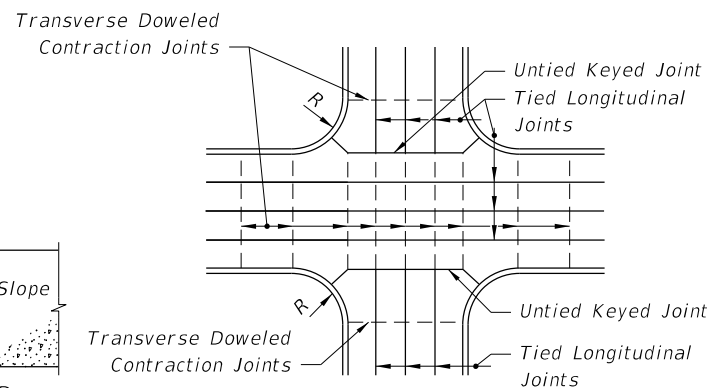

JOINT LAYOUT AT THRU INTERSECTION

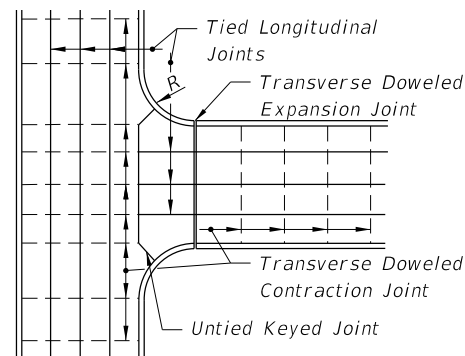

JOINT LAYOUT AT 'T' INTERSECTIONS

JOINT ARRANGEMENT

NOTES

1. Longitudinal joints will not be required for single lane pavement 14' or less in width. For entrance and exit ramp joint details, see Sheet 4.
2. Arrangement of longitudinal joints are to be as directed by the Engineer.
3. All manholes, meter boxes and other projections into the pavement shall be boxed-in with 1/2" preformed expansion joint material.

C:\projects\standards\roadway\00300-s\00305-03.dgn 11:41:06 AM r19960/h 12/30/2011

LAST REVISION	00	DESCRIPTION:	 FDOT DESIGN STANDARDS FY 2012/2013	CONCRETE PAVEMENT JOINTS	INDEX NO.	SHEET NO.
					305	3

C:\projects\standards\roadway\0300-s\0305-04.dgn
 r19960/h
 11:41:07 AM
 12/30/2011

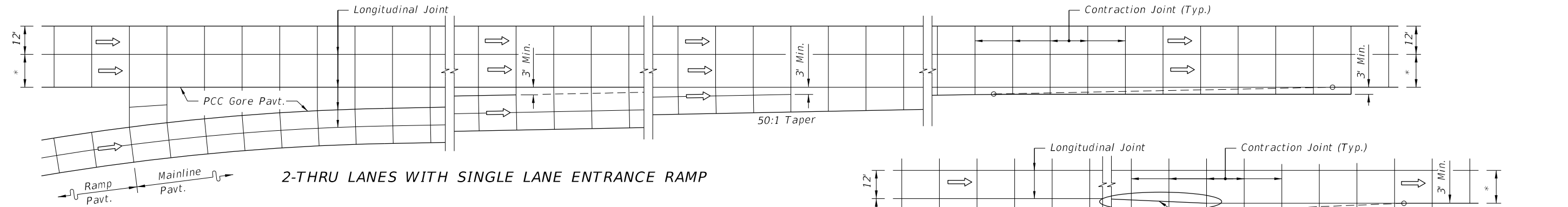

2-THRU LANES WITH SINGLE LANE ENTRANCE RAMP

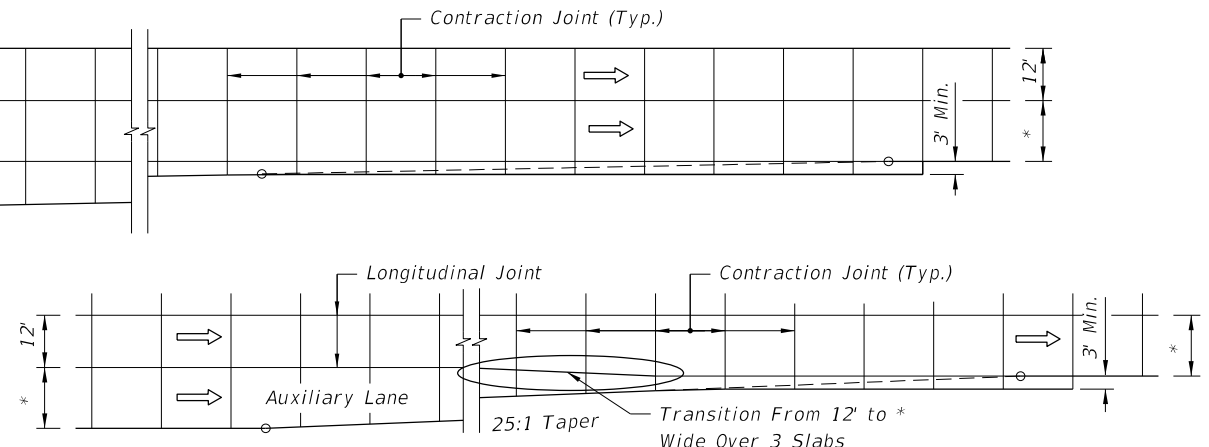

ENTRANCE TAPER WITH AUXILIARY LANE

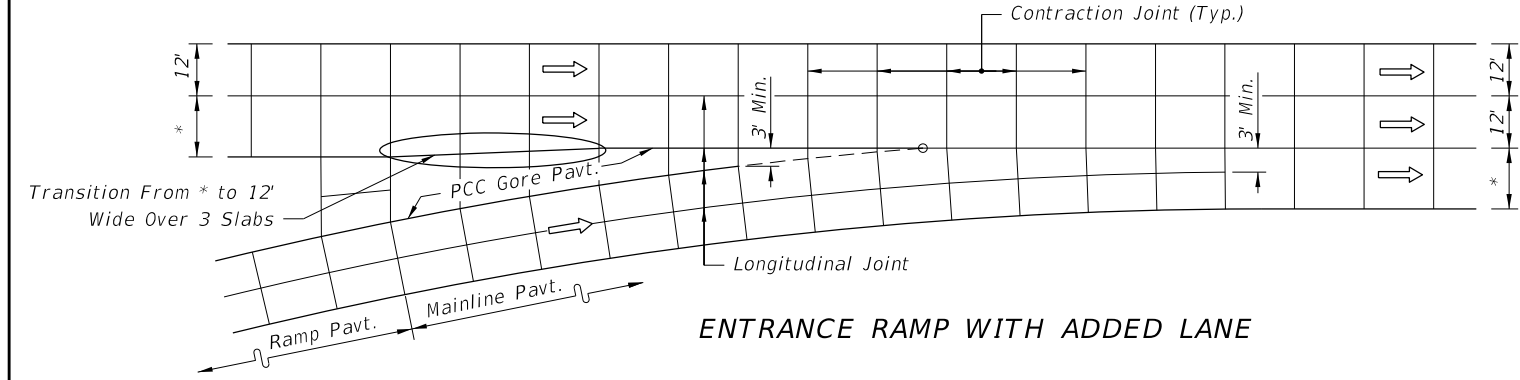

ENTRANCE RAMP WITH ADDED LANE

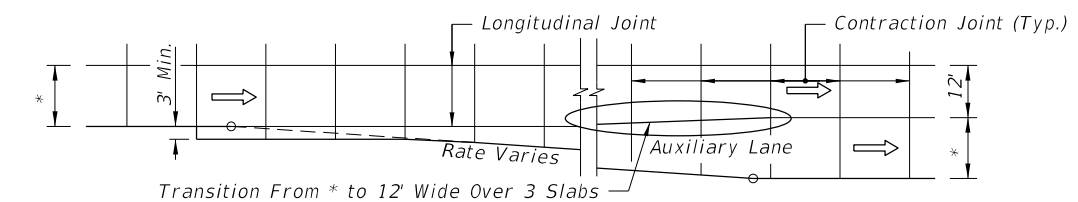

EXIT TAPER WITH AUXILIARY LANE

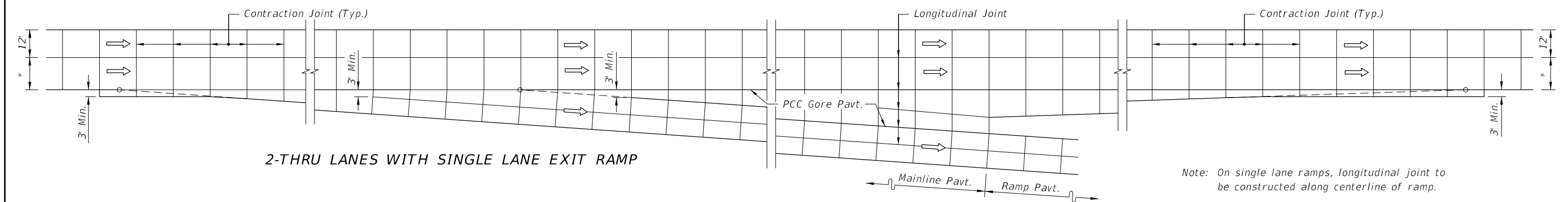

2-THRU LANES WITH SINGLE LANE EXIT RAMP

Note: On single lane ramps, longitudinal joint to be constructed along centerline of ramp.

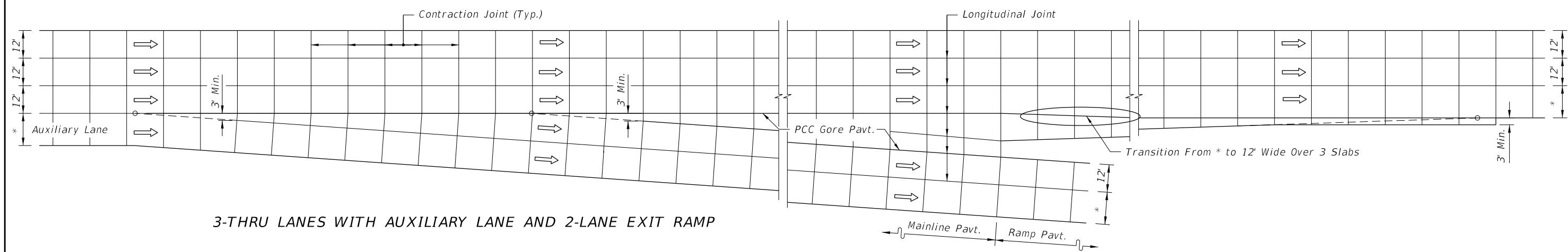

3-THRU LANES WITH AUXILIARY LANE AND 2-LANE EXIT RAMP

JOINT LAYOUT AT ENTRANCE AND EXIT RAMP TERMINALS

* 13' with tied Concrete Shoulders or 14' with Asphalt Shoulders.

LAST REVISION	DESCRIPTION:	 FDOT DESIGN STANDARDS FY 2012/2013	CONCRETE PAVEMENT JOINTS		INDEX NO.	SHEET NO.
07/01/09					305	4