

Pipe Size	Grate Bars Req'd.	Grate LB.
15"	2	28.93

Bars to be evenly spaced across dimension 'D'.
All bars 1/2" x 2"

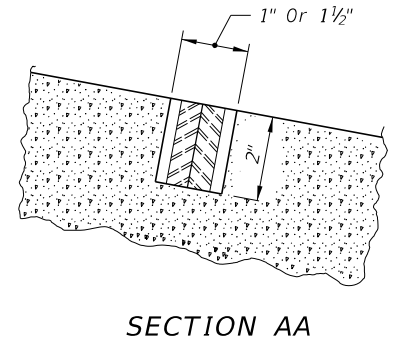

SECTION AA

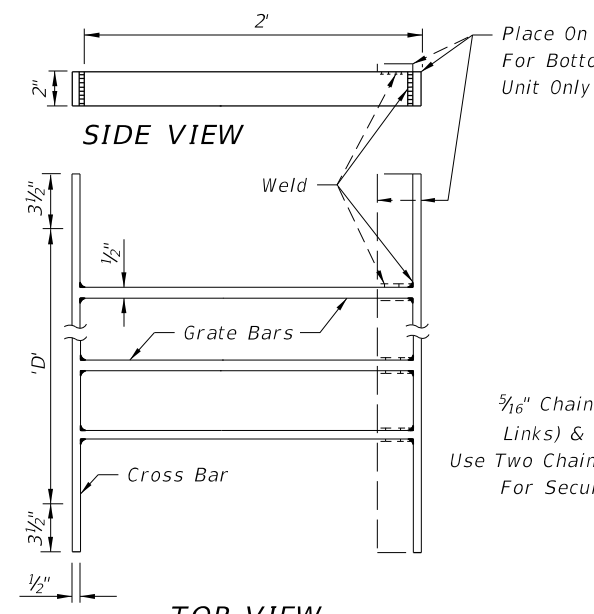

Pipe Size	Grate Bars Req'd.	Grate LB.
18"	3	33.69
24"	4	43.63
30"	5	53.55

Bars to be evenly spaced across dimension 'D'.
All bars 1/2" x 2"

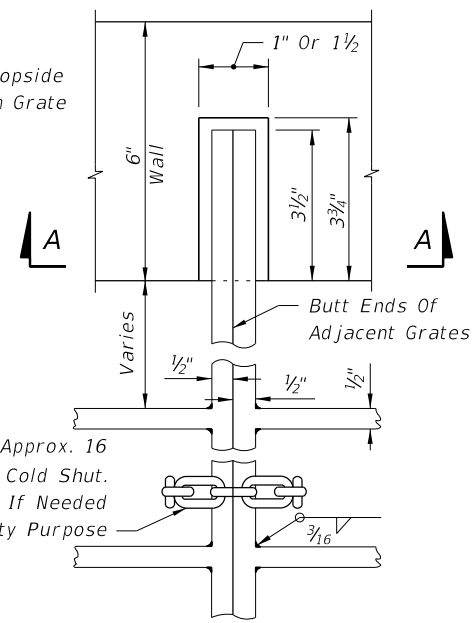

TOP VIEW
GRATE, SEAT,
WELD & CHAIN DETAIL

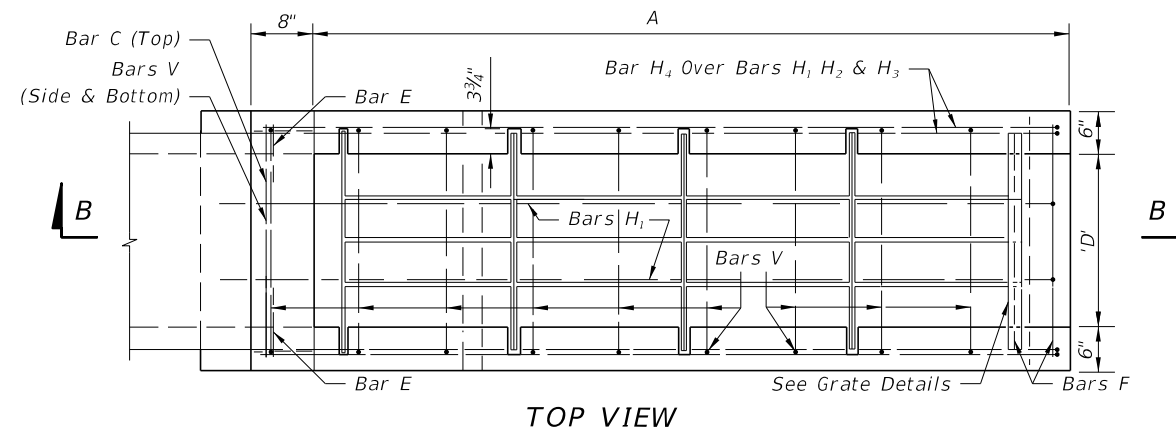
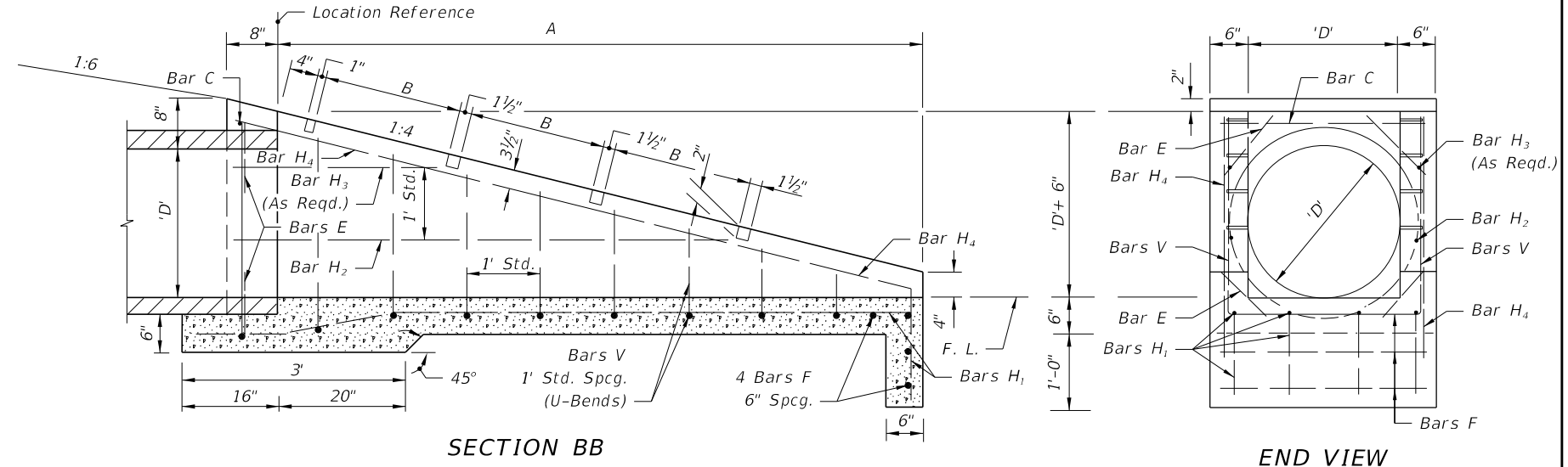

Slope	TABLE OF DIMENSIONS AND QUANTITIES										
	Pipe Size D	A	B	Class I Conc. (CY)	Reinf. Steel (Lbs.)	Number Of Grates Req'd.		Total Grate Wt. (Lbs.)	Sodding (SY)	Slope Transition	
						Type No. 1	Type No. 2			Offset	L
1:4	15"	5.67'	2.38'	0.85	56	2	0	57.86	15	4.2'	42'
	18"	6.67'	1.875'	1.01	73	0	3	101.08	16	4.8'	48'
	24"	8.67'	1.875'	1.65	97	0	4	174.52	19	5.8'	58'
	30"	10.67'	1.875'	2.33	129	0	5	267.75	21	6.9'	69'

GENERAL NOTES

- This endwall is to be used only in the clear zone for the drainage of medians and other areas having low design velocities and negligible debris.
- Reinforcing steel: All bars are size #4. Spacings shown are center to center. Laps to be 12" minimum. Clearance is 2" except as noted. Square welded wire fabric (two cages max.) having an equivalent cross sectional area (0.20 sq. in.) may be substituted for bar reinforcement.
- Grates shall be ASTM A242/A242M, A572/A572M or ASTM A5888/A588M, Grade 50 steel. When "Alt. G" grates are specified in the plans, grates shall be galvanized in accordance with Section 975 and 425.3.2 of the Standard Specifications.
- Endwall to be paid for under the contract unit price for U-Endwall, Each. Payment shall include cost of concrete, reinforcing steel, grate, and accessories. Quantities shown are for estimating purposes only.
- Sod slopes 5' each side and above endwall. Sodding to be paid for under contract unit price for Performance Turf, SY.
- Precasting of this endwall will be permitted. Precast units shall conform to the dimensions shown or in accordance with approved shop drawings. Request for shop drawing approval shall be directed to the State Drainage Engineer. Use Index No. 201 for opening and grouting details.
- Concrete shall be Class I except ASTM C478 (4000 psi) concrete may be substituted for precast items manufactured in plants meeting the requirements of Section 449 of the Specifications.

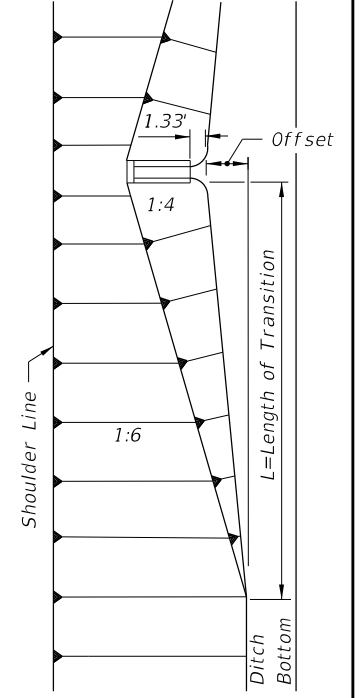

FRONT SLOPE
TRANSITION AT ENDWALL

C:\projects\standards\roadway\0200-s\02060-01.dgn 11:39:52 AM r0960rh 12/30/2011