

C:\projects\standards\roadway\0200-s\020232-01.dgn  
 r0960rh  
 11:39:28 AM  
 12/30/2011

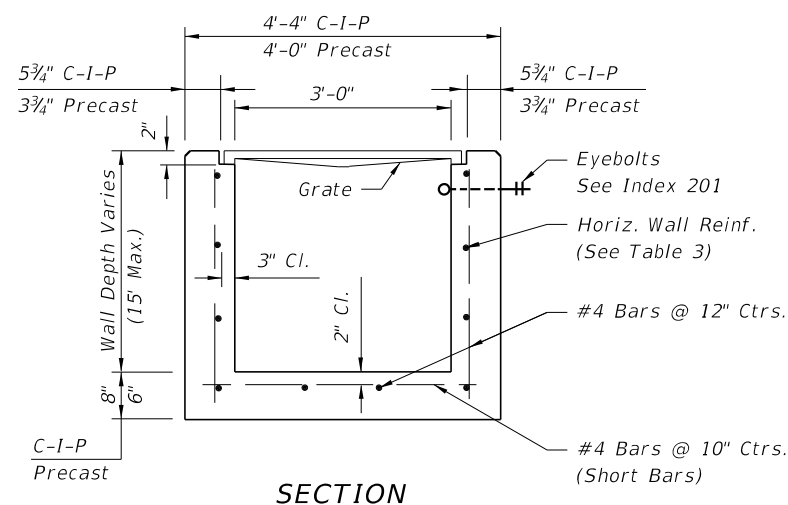
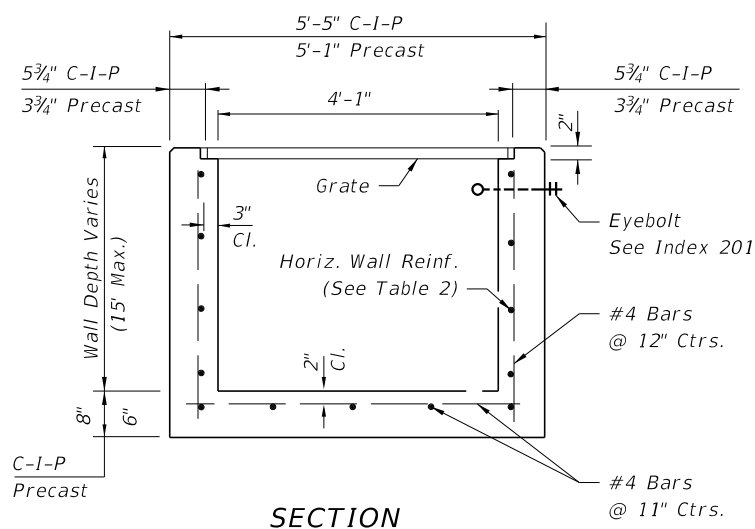
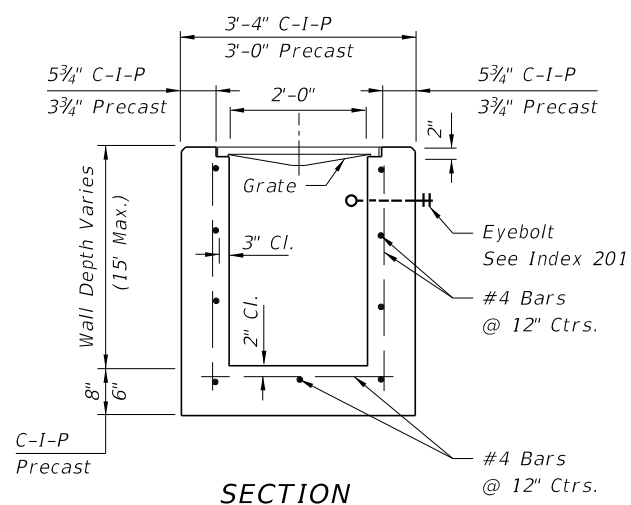
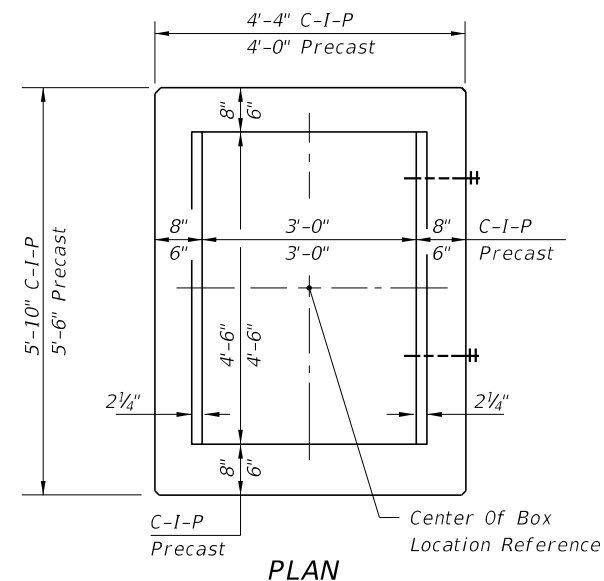
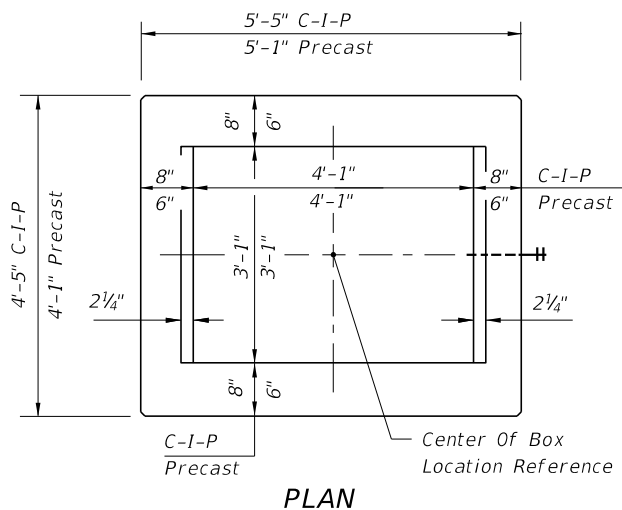
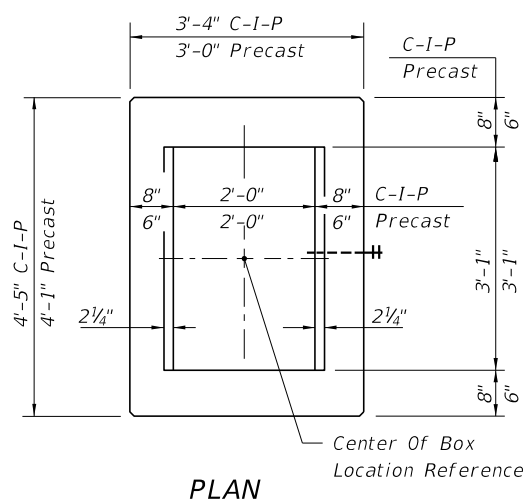

HORIZONTAL WALL REINFORCING SCHEDULES (TABLE 1)

WALL DEPTH	SCHEDULE	AREA (in. <sup>2</sup> /ft.)	MAX. SPACING	
			BARS	WWF
0'-15'	A12	0.20	12"	8"

**TYPE C**

Recommended Maximum Pipe Size:

- 2'-0" Wall - 18" Pipe
- 3'-1" Wall - 24" Pipe (18" where an 18" pipe enters a 2'-0" wall)

HORIZONTAL WALL REINFORCING SCHEDULES (TABLE 2)

WALL DEPTH	SCHEDULE	AREA (in. <sup>2</sup> /ft.)	MAX. SPACING	
			BARS	WWF
0'-6'	A12	0.20	12"	8"
6'-10'	A6	0.20	6"	5"
10'-13'	A4	0.20	4"	3"
10'-15'	B5.5	0.24	5 1/2"	5"

**TYPE D**

Recommended Maximum Pipe Size:

- 3'-1" Wall - 24" Pipe
- 4'-1" Wall - 36" Pipe

HORIZONTAL WALL REINFORCING SCHEDULES (TABLE 3)

WALL DEPTH	SCHEDULE	AREA (in. <sup>2</sup> /ft.)	MAX. SPACING	
			BARS	WWF
0'-5'	A12	0.20	12"	8"
0'-7.5'	A6	0.20	6"	5"
7.5'-10'	B5.5	0.24	5 1/2"	5"
10'-15'	C6.5	0.37	6 1/2"	6"

**TYPE E**

Recommended Maximum Pipe Size:

- 3'-0" Wall - 24" Pipe
- 4'-6" Wall - 36" Pipe

LAST REVISION	DESCRIPTION:
07/01/05	



FDOT DESIGN STANDARDS  
FY 2012/2013

DITCH BOTTOM INLET TYPES C, D, E AND H

INDEX NO.	SHEET NO.
232	1

12/30/2011 11:39:29 AM r1960/h C:\projects\standards\roadway\0200-s\02032-02.dgn

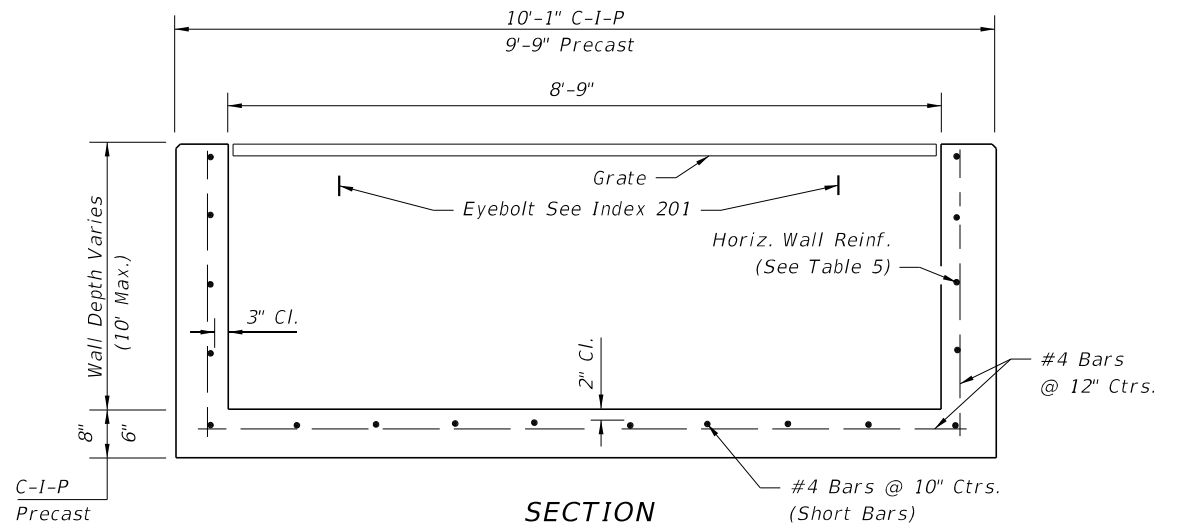
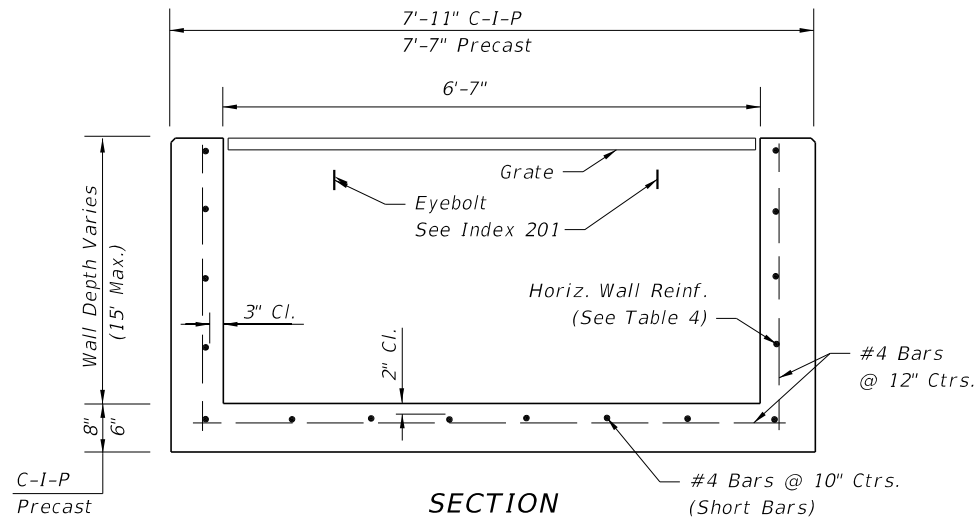
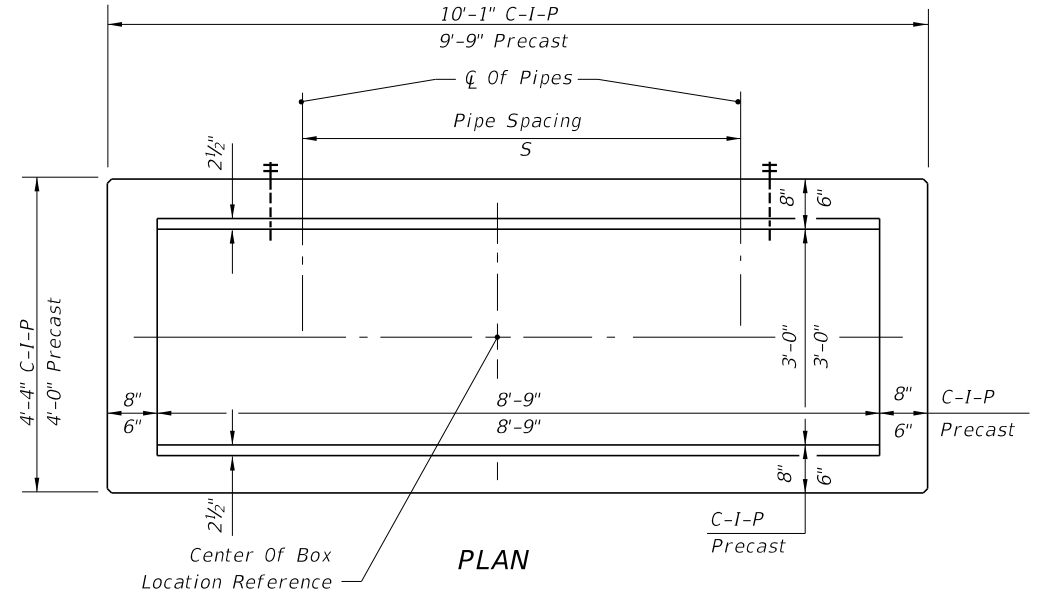
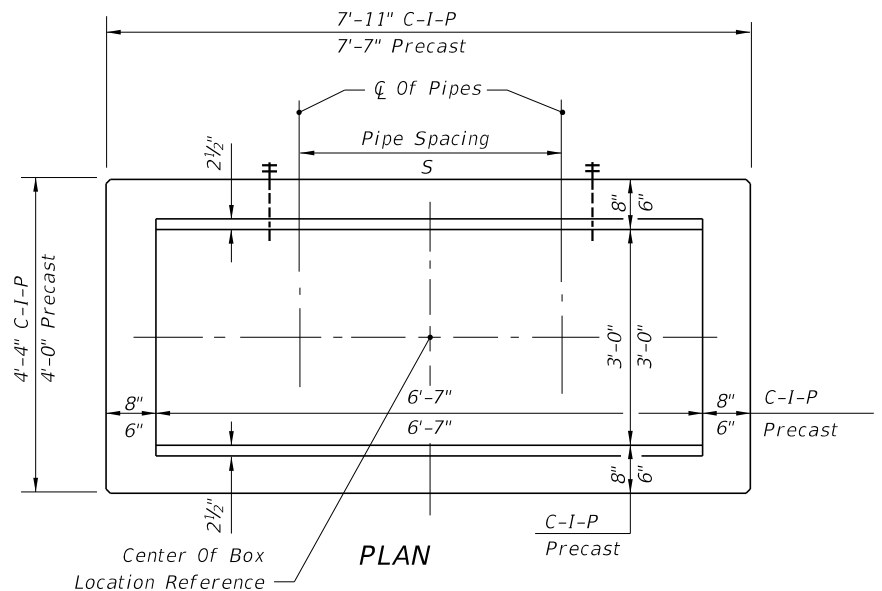

**HORIZONTAL WALL REINFORCING SCHEDULES (TABLE 4)**

WALL DEPTH	SCHEDULE	AREA (in. <sup>2</sup> /ft.)	MAX. SPACING	
			BARS	WWF
0'-5'	B5.5	0.24	5 1/2"	5"
5'-7'	C6.5	0.37	6 1/2"	6"
7'-15'	D4.5	0.53	4 1/2"	4"

**HORIZONTAL WALL REINFORCING SCHEDULES (TABLE 5)**

WALL DEPTH	SCHEDULE	AREA (in. <sup>2</sup> /ft.)	MAX. SPACING	
			BARS	WWF
0'-5'	C3.5	0.37	3 1/2"	3"
5'-10'	D4.5	0.53	4 1/2"	4"

**TYPE H (2 & 3-GRATE INLET)**

Recommended Maximum Pipe Size:  
 3'-0" Wall - 24" Pipe  
 6'-7" Wall - 1-60" Pipe  
 Or 2-24" Pipe (S=3'-5")

**TYPE H (4-GRATE INLET)**

Recommended Maximum Pipe Size:  
 3'-0" Wall - 24" Pipe  
 8'-9" Wall - 1-78" Pipe  
 Or 2-30" Pipe (S=4'-3")

**GENERAL NOTES**  
 See Sheet 3 of 7.

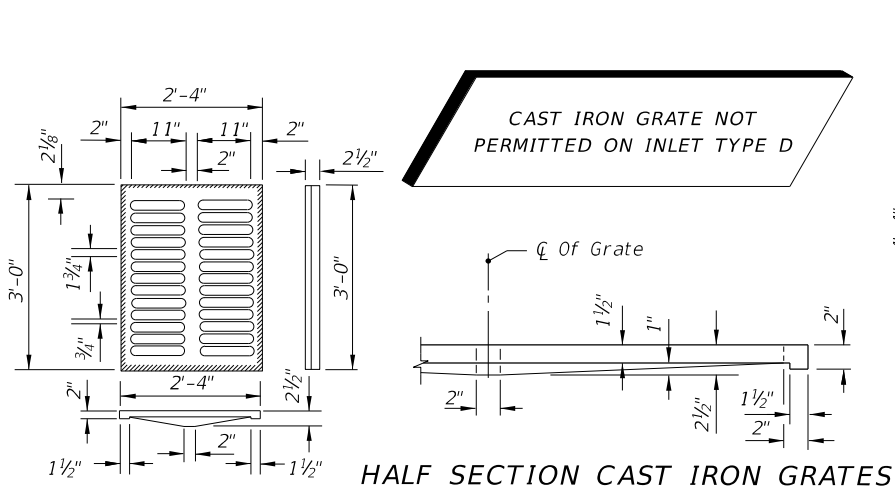

HALF SECTION CAST IRON GRATES

**TYPE C**  
Approx. Weight 235 Lbs.

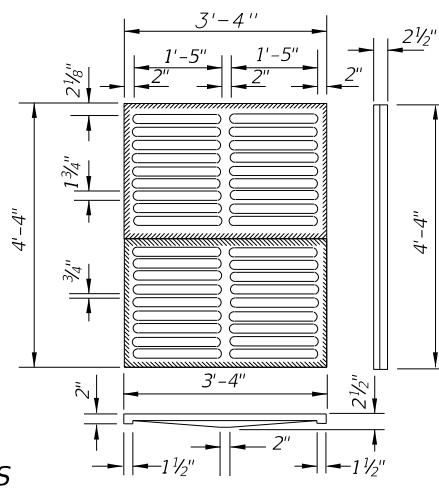

**TYPE E**  
Approx. Weight 465 Lbs.

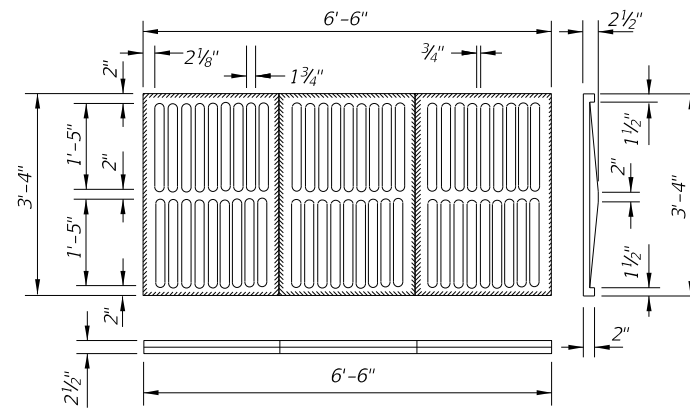

**TYPE H (3-GRATE INLET)**  
Approx. Weight 725 Lbs.

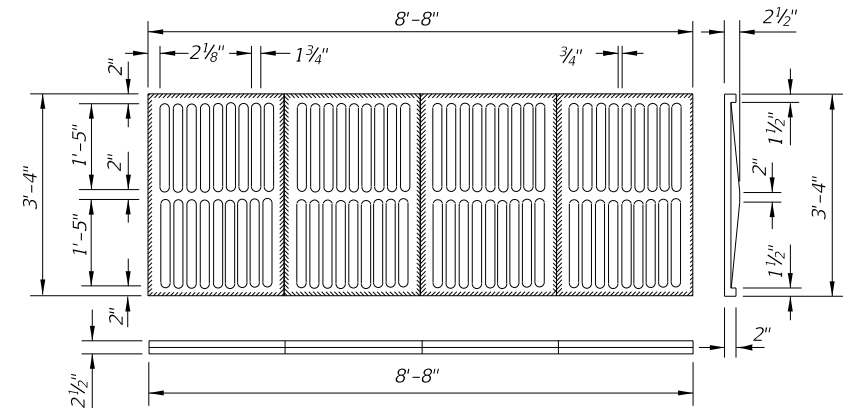

**TYPE H (4-GRATE INLET)**  
Approx. Weight 967 Lbs.

**CAST IRON GRATES**

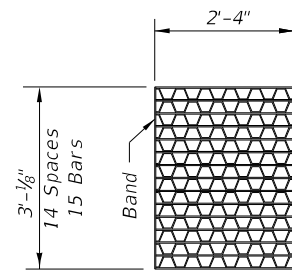

**TYPE C**

Straight Bars 2" x 1/4"  
Reticuline Bars 1 1/4" x 3/16"  
Bands 2" x 1/4"  
Approx. Weight 104 Lbs.

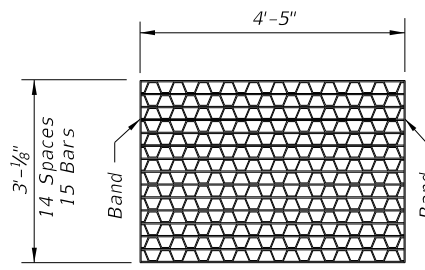

**TYPE D**

Straight Bars 2" x 1/4"  
Reticuline Bars 1 1/4" x 3/16"  
Bands 2" x 1/4"  
Approx. Weight 190 Lbs.

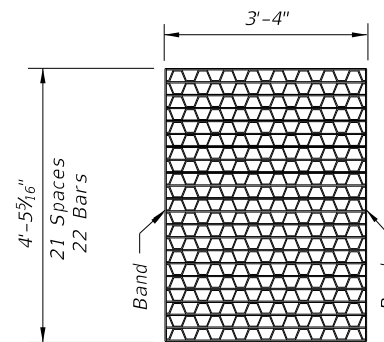

**TYPE E**

Straight Bars 2" x 1/4"  
Reticuline Bars 1 1/4" x 3/16"  
Bands 2" x 1/4"  
Approx. Weight 215 Lbs.

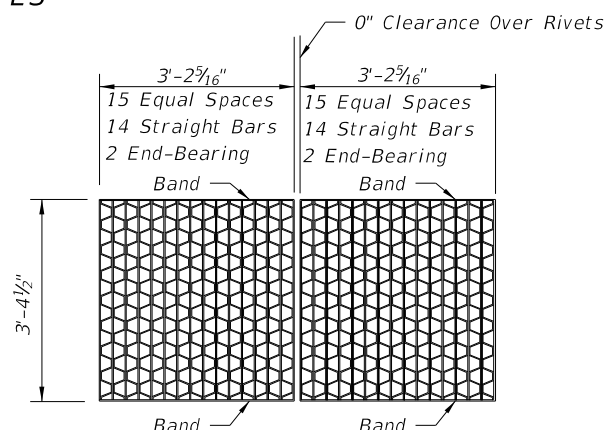

**TYPE H (2-GRATE INLET)**

Straight End-Bearing Bars 2" x 3/8"      Banding Bars 2" x 1/4"  
Straight Bearing Bars 2" x 1/4"      Approx. Total Weight 310 Lbs.  
Reticuline Bars 1 1/4" x 3/16"

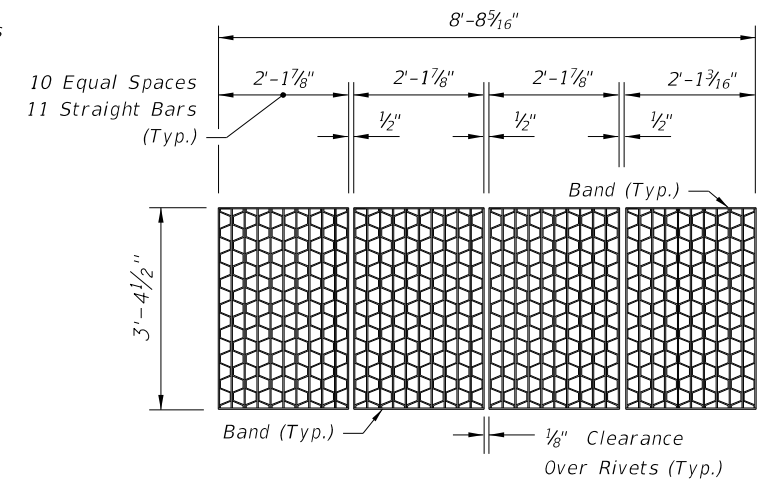

**TYPE H (4-GRATE INLET)**

Straight End-Bearing Bars 2" x 1/4"  
Reticuline Bars 1 1/4" x 3/16"  
Banding Bars 2" x 3/16"  
Approx. Total Weight 388 Lbs.

**STEEL GRATES**

NOTE: Steel Grates Are Required On Inlets With Traversable Slots And On Inlets where Bicycle Traffic Is Anticipated.

**GENERAL NOTES**

- These inlets are suitable for bicycle traffic and are to be used in ditches, medians and other areas subject to infrequent traffic loadings but are not to be placed in areas subject to any heavy wheel loads. These inlets may be placed in areas subject to occasional pedestrian traffic such as landscaped areas and pavement areas where pedestrians can walk around the inlet.
- Inlets subject to minimal debris should be constructed without slots. Where debris is a problem inlets should be constructed with slots. Slotted inlets located within roadway clear zones and areas subject to pedestrians shall have traversable slots. The traversable slot modification is not adaptable to inlet Type H. Slots may be constructed at either or both ends as shown on plans. Traversable slots shall not be used in areas subject to occasional bicycle traffic.
- Steel grates are to be used on all inlets where bicycle traffic is anticipated. Steel grates are to be used on all inlets with traversable slots. Either cast iron or steel grates may be used on inlets without slots where bicycle traffic is not anticipated. Either cast iron or steel grates may be used on all inlets with non-traversable slots. Subject to the selection described above, when Alternate G grate is specified in the plans, either the steel grate, hot dip galvanized after fabrication, or the cast iron grate may be used, unless the plans stipulate the particular type.
- Recommended maximum pipe sizes shown are for concrete pipe. Size for other types of pipe must be checked for fit.
- All exposed edges and corners shall be 3/4" chamfer or tooled to 1/4" radius.
- Concrete inlet pavement to be used on inlets without slots and inlets with non-traversable slots only when called for in the plans; but required on all traversable slot inlets. Cost to be included in contract unit price for inlets. Quantities shown are for information only.
- Traversable slots constructed in existing inlets shall be paid for as inlets partial. For conversion work and method of payment see 'TRAVERSABLE SLOT INLETS (PARTIAL) FOR EXISTING INLETS'.
- Sodding to be used on all inlets not located in paved areas and paid for under contract unit price for Performance Turf, SY.
- For supplementary details see Index No. 201.
- All reinforcing is Grade 60 bars with 2" min. cover unless otherwise noted. Bars to be cut or bent for 1 1/2" clearance around pipe opening. Provide one additional #4 bar above and at each side of pipe opening.

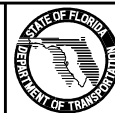

**FDOT DESIGN STANDARDS**  
FY 2012/2013

**DITCH BOTTOM INLET TYPES C, D, E AND H**

LAST REVISION  
07/01/10

REVISION  
DESCRIPTION:

INDEX NO.  
232  
SHEET NO.  
3

12/30/2011 11:39:29 AM r10960/h C:\projects\standards\roadway\0200-s\02032-03.dgn

C:\projects\standards\roadway\0200-s\020232-04.dgn  
 r1960rh  
 11:39:30 AM  
 12/30/2011

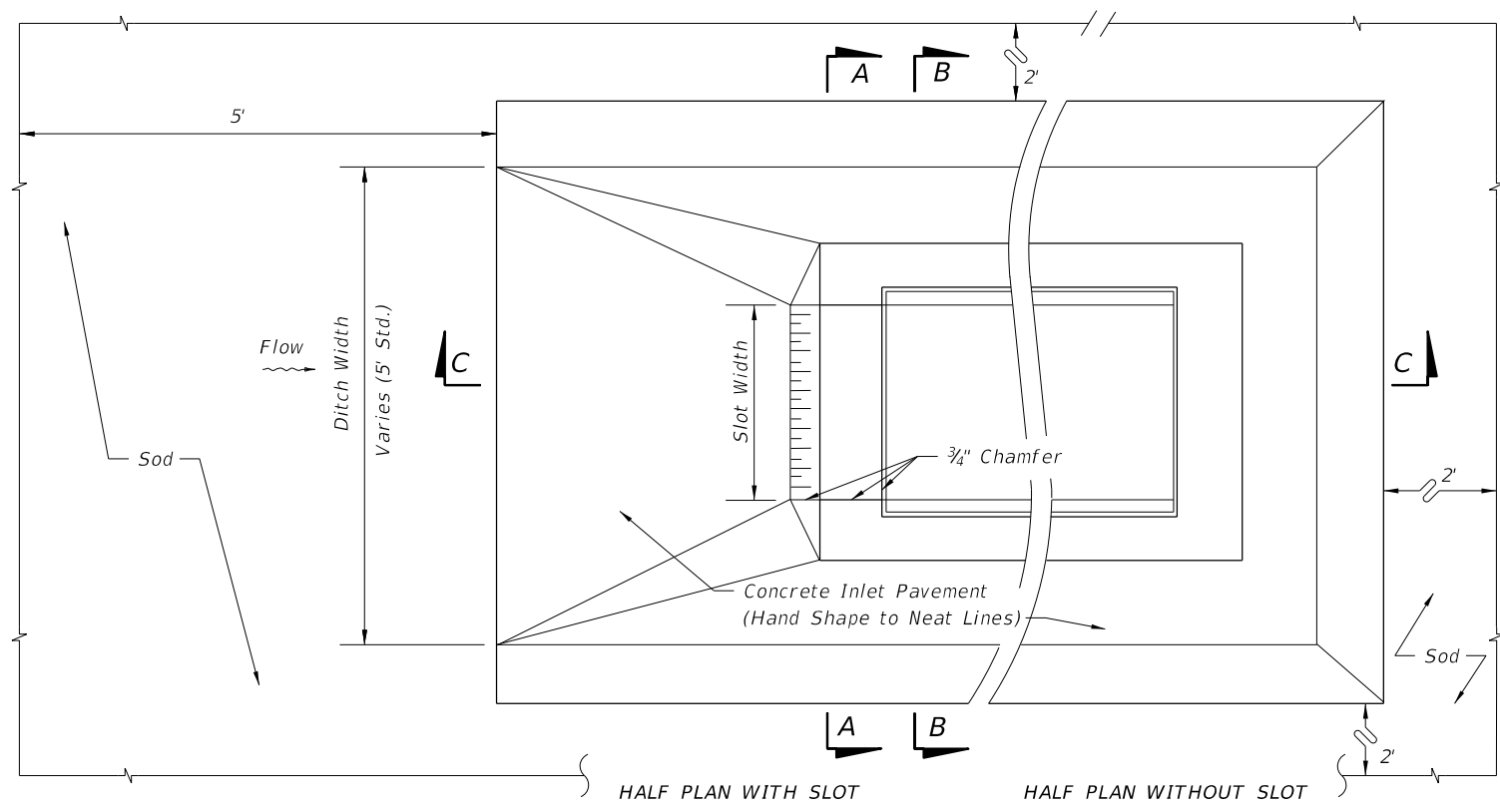

PLAN VIEW

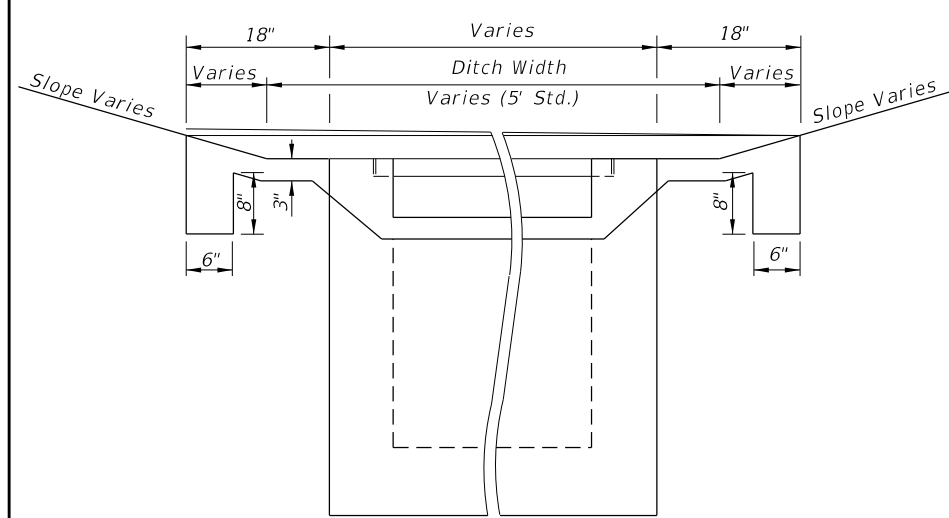

SECTION AA

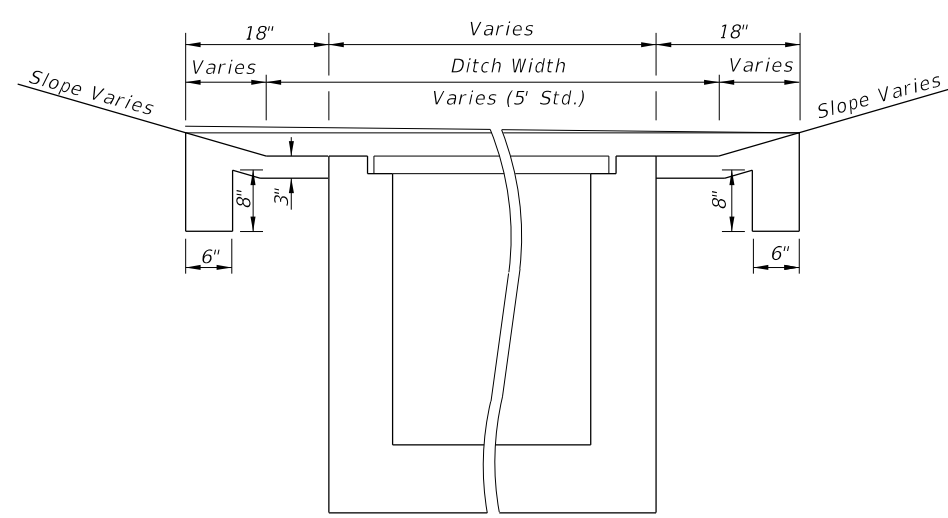

SECTION BB

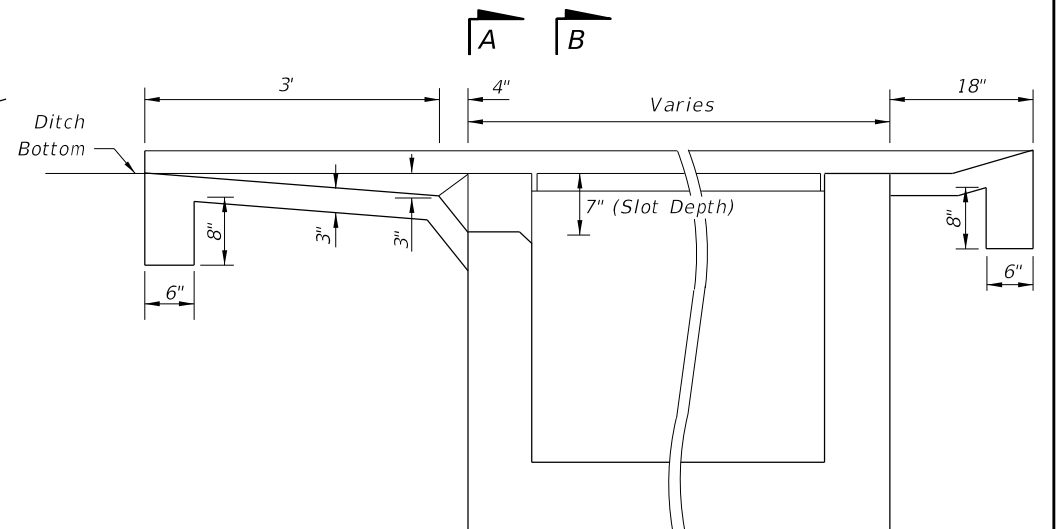

SECTION CC

PAVEMENT AND SODDING QUANTITIES FOR TRAVERSABLE SLOTS					
Inlet	Pavement		Sod		
	Single Slot	Double Slot	Single Slot	Double Slot	
	SY	CY	SY	CY	SY
C	4.87	0.77	6.16	0.93	12
D	5.99	0.91	7.70	1.10	14
E	5.88	0.91	7.37	1.08	18

TRAVERSABLE SLOTS

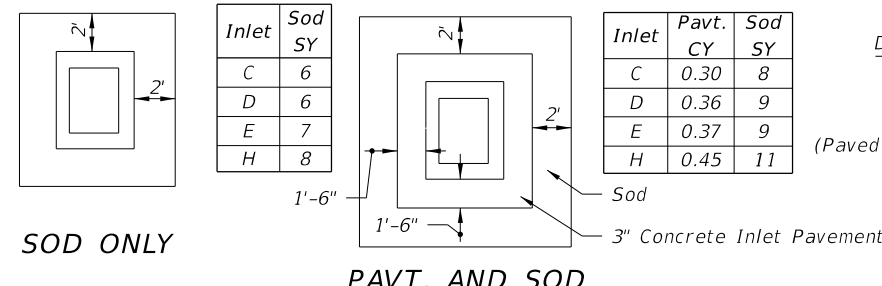
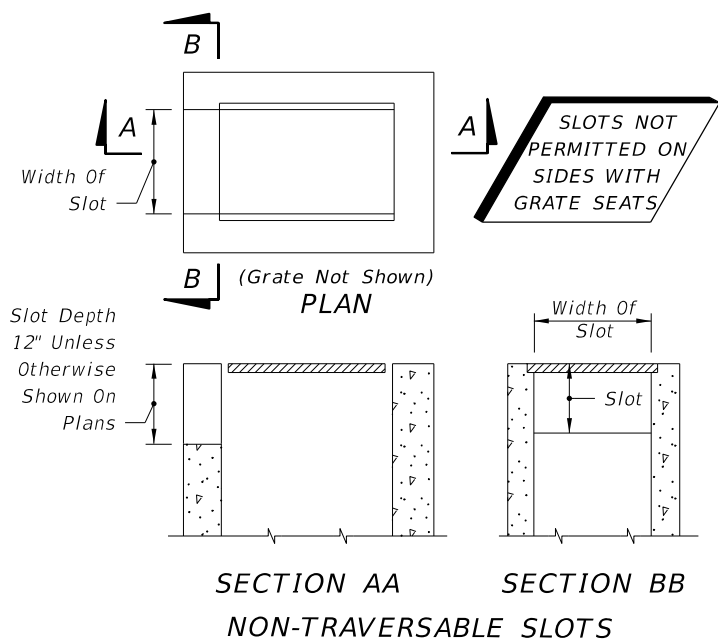

NOTE: See General Notes Nos. 6 and 7, Sheet 3 of 7.  
**SODDING AND PAVEMENT FOR INLETS WITHOUT SLOTS AND INLETS WITH NON-TRAVERSABLE SLOTS**

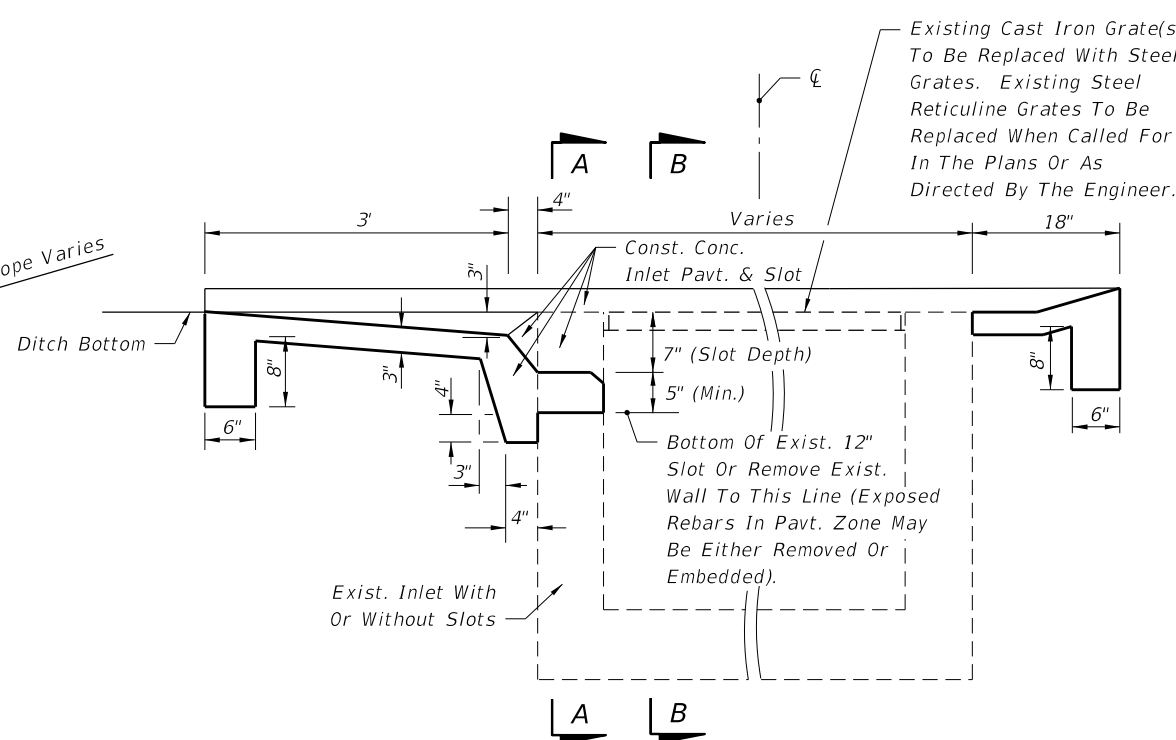
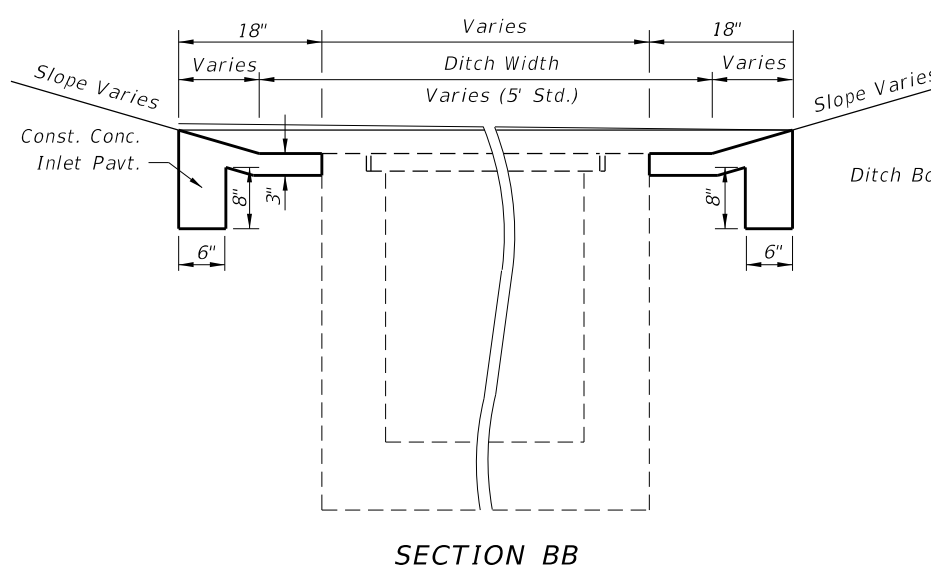
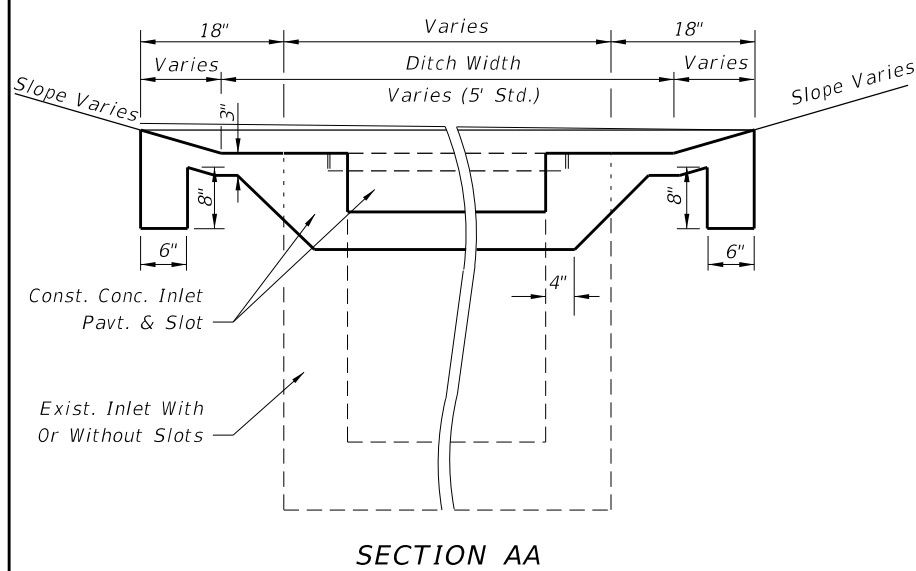
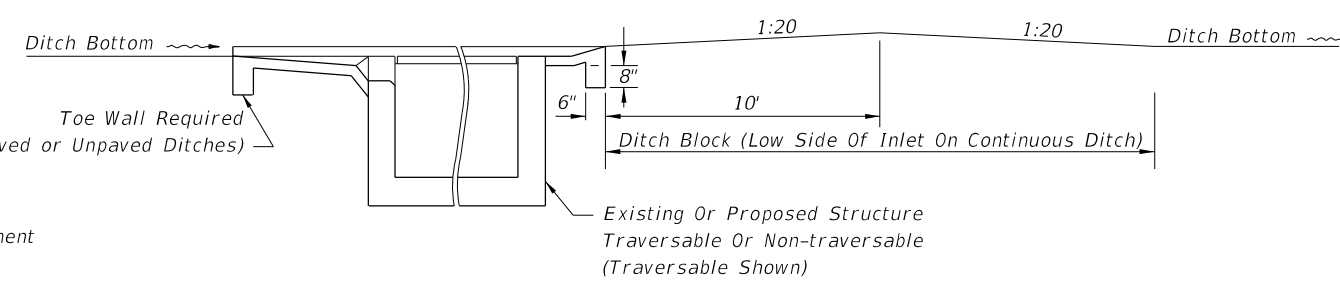

**SINGLE SLOT SHOWN (DOUBLE SLOTS SYMMETRICAL ABOUT CENTERLINE)**  
**SECTION CC (CASE I)**

Inlet	Pavement				Sod	
	Single Slot		Double Slot		Single Slot	Double Slot
	SY	CY	SY	CY	SY	SY
C	4.87	0.83	6.16	1.05	12	16
D	5.99	1.01	7.70	1.30	14	19
E	5.88	0.99	7.37	1.24	14	18

NOTE: For plan view and additional details see Sheet 4 of 7.  
 For payment see General Notes Nos. 6 and 7, Sheet 3 of 7.  
**TRAVERSABLE SLOTS FOR EXISTING INLETS**

C:\projects\standards\roadway\0200-s\020232-05.dgn  
 11:39:31 AM  
 r1960rh  
 12/30/2011

**DESIGN NOTES FOR TRAVERSABLE SLOT INLETS (PARTIAL) FOR EXISTING INLETS**

1. The general purpose of these conversions is to remove the hazard of the protruding inlet top, while not creating a hazard by depressing the top too deeply.
2. The corrective procedure depends on the approach ditch grade and hydraulic requirements of the site. The selection of the appropriate case depends on the relationship between inlet top and ditch elevation, and, on the vertical clearance between the top of the uppermost pipe(s) and the grate. The purpose for the Case 1 conversion is to add the traversable slot to an existing inlet where top removal, change in grate elevation and ditch transitions are not required. Case 2 will normally be applicable to ditches with flatter grades adjoining the inlet. Case 3 will normally be applicable to ditches with steeper grades adjoining the inlet where build up of the existing ditch is acceptable.
3. The designer shall stipulate in the plans which case is to be constructed at each individual inlet location.

Where the existing inlet top is above the existing ditch (Case 2) but borrow material will be required to adjust the ditch (Case 3), and vertical clearance or other conditions do not prevent removal of the inlet top, the designer should call for Case 2. The designer shall determine if ditch reconstruction is required more than 35 feet beyond any traversable slot side and shall include separate pay items in the plans to cover the cost for that portion of required ditch reconstruction exceeding the 35 foot limit. The designer shall also determine whether ditch pavement is required for ditch restoration within the 35 foot limit and include that pavement under a pay item separate from the inlets partial.

When the detention ditch concept is to be used with Case 3, the designer shall stipulate 'Case 3 (Detention)' in the plans.

The designer shall determine whether tight soil or other conditions at each individual inlet indicates the need for underdrain in Case 3 conversions and shall call for Underdrain, Type 1 in the plans.

**METHOD OF PAYMENT FOR TRAVERSABLE SLOT INLETS (PARTIAL) FOR EXISTING INLETS**

1. Existing inlets converted to traversable slot tops under Cases 1, 2 and 3 shall be paid for as inlets partial, each. Case shall not be included in the pay item description.
2. All ditch reconstruction work within 35 feet of each traversable slot conversion, whether required by these details or as a direct result of the conversion, shall be included as a part of the partial cost. Reconstruction work shall include excavation and removal of surplus materials or borrow materials in place, grading, compaction, shaping and restoration of disturbed turf. Sodding, ditch pavement and underdrain are not included as part of the inlet partial cost and are to be paid for separately.
3. Concrete inlet pavement and sodding shall be in accordance with the sections on this detail and with the Plan on Sheet 4 and Sections AA, BB and CC (as Case 1) and tabular quantities on Sheet 5.
4. Unit price and payment shall constitute full compensation for inlet conversion (including concrete inlet paving and replacement grate(s)), ditch reconstruction, restoration of disturbed turf, and shall be paid for under the contract price for Inlets (DT Bot) (Type \_\_) (Partial), each.

Sodding shall be paid for under the contract unit price for Performance Turf, SY.

Ditch pavement shall be paid for separate from the inlet by pavement type(s) and unit(s) as called for in the plans.

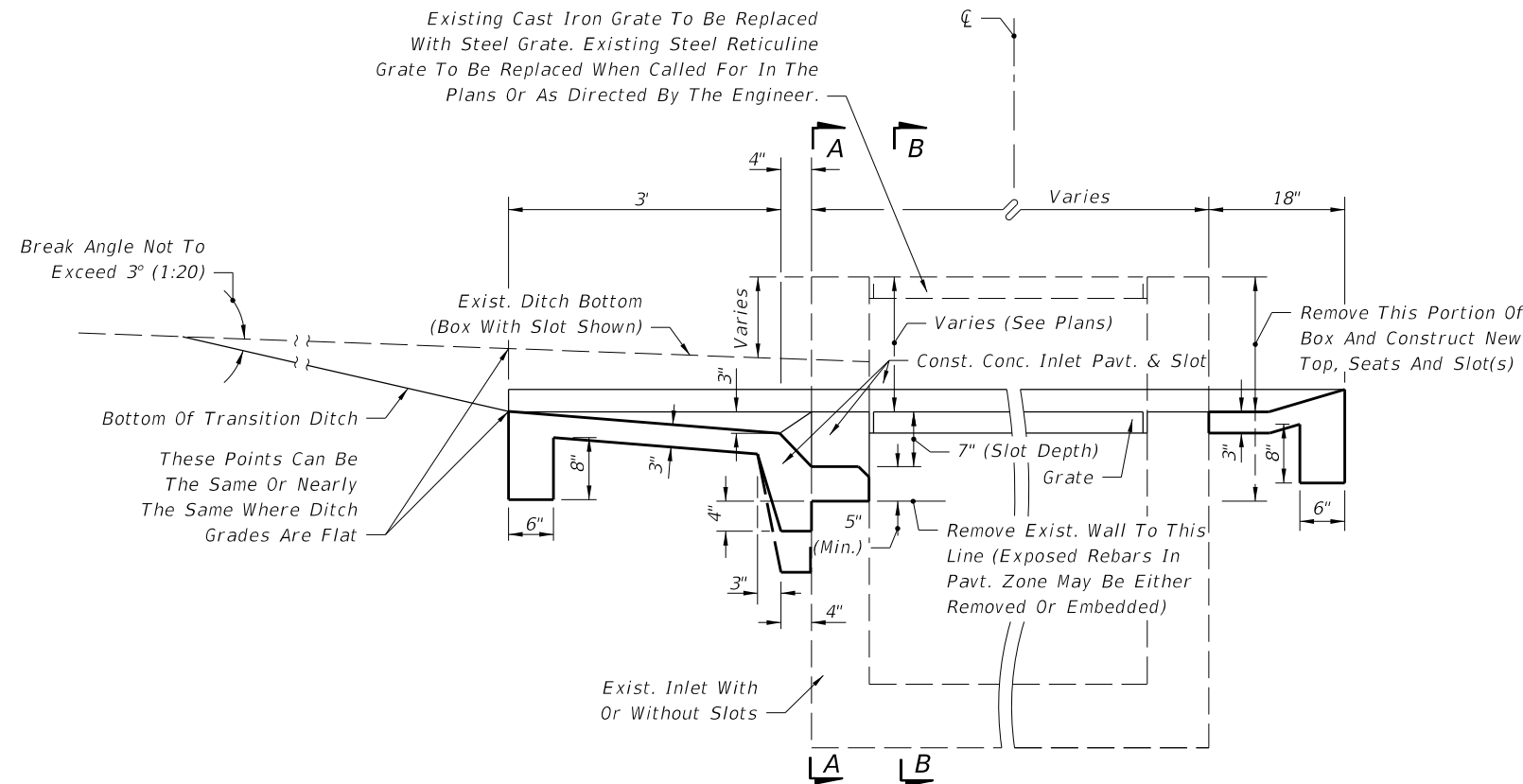

**SINGLE SLOT SHOWN (DOUBLE SLOTS SYMMETRICAL ABOUT CENTERLINE) SECTION CC (CASE 2)**

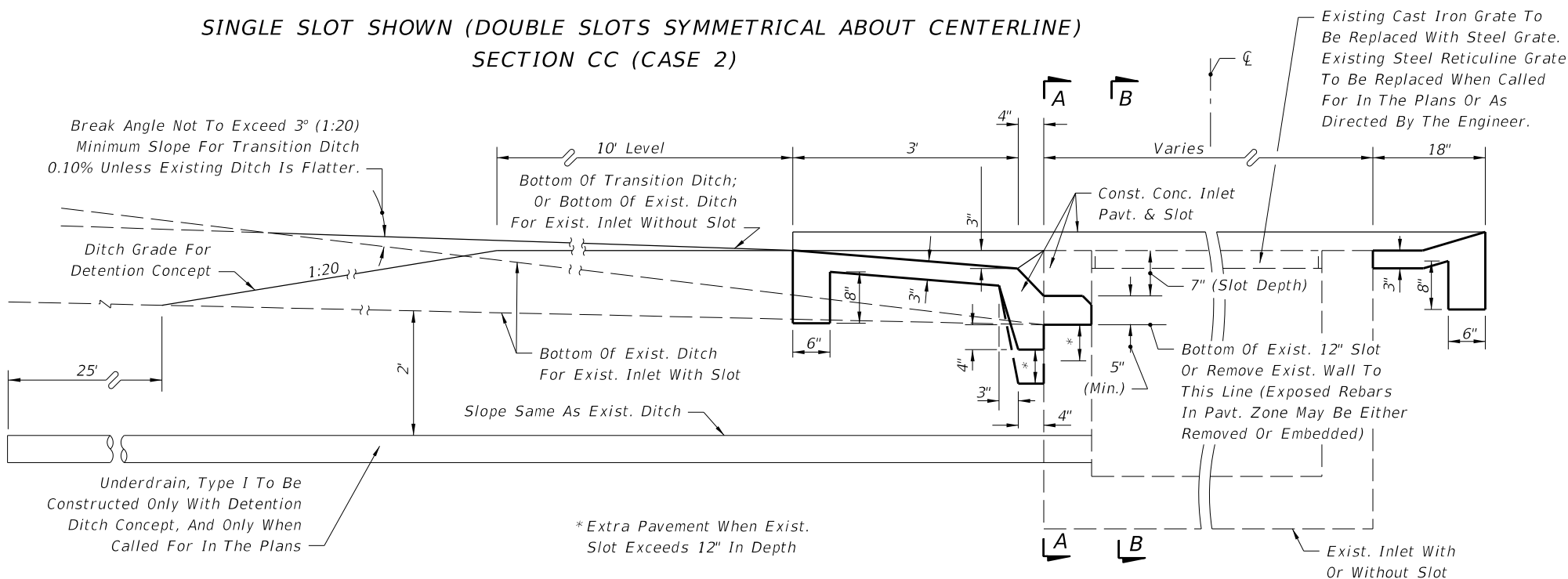

**SINGLE SLOT SHOWN (DOUBLE SLOTS SYMMETRICAL ABOUT CENTERLINE) SECTION CC (CASE 3)**

**TRAVERSABLE SLOT INLETS (PARTIAL) FOR EXISTING INLETS**

C:\projects\standards\roadway\0200-s\020232-06.dgn 11:39:32 AM 12/30/2011

LAST REVISION	DESCRIPTION:	 <b>FDOT DESIGN STANDARDS</b> FY 2012/2013	<b>DITCH BOTTOM INLET TYPES C, D, E AND H</b>	INDEX NO. <b>232</b>	SHEET NO. <b>6</b>
07/01/07					

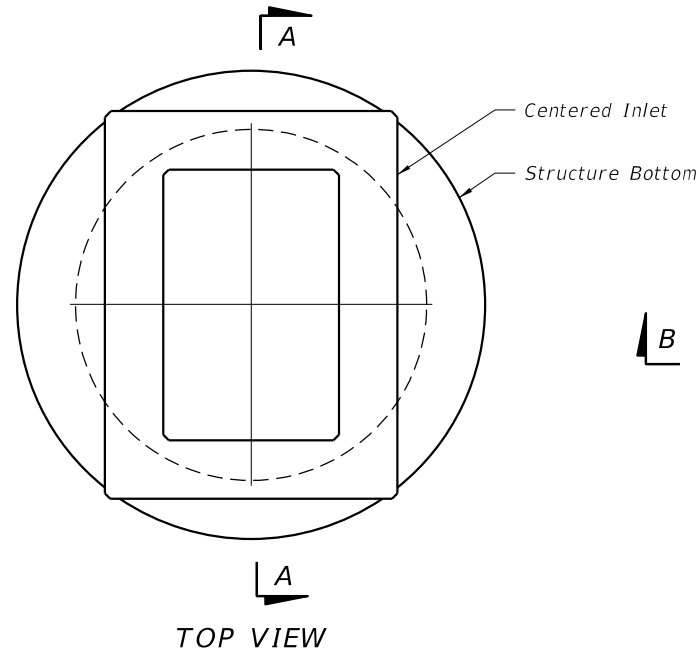

TOP VIEW

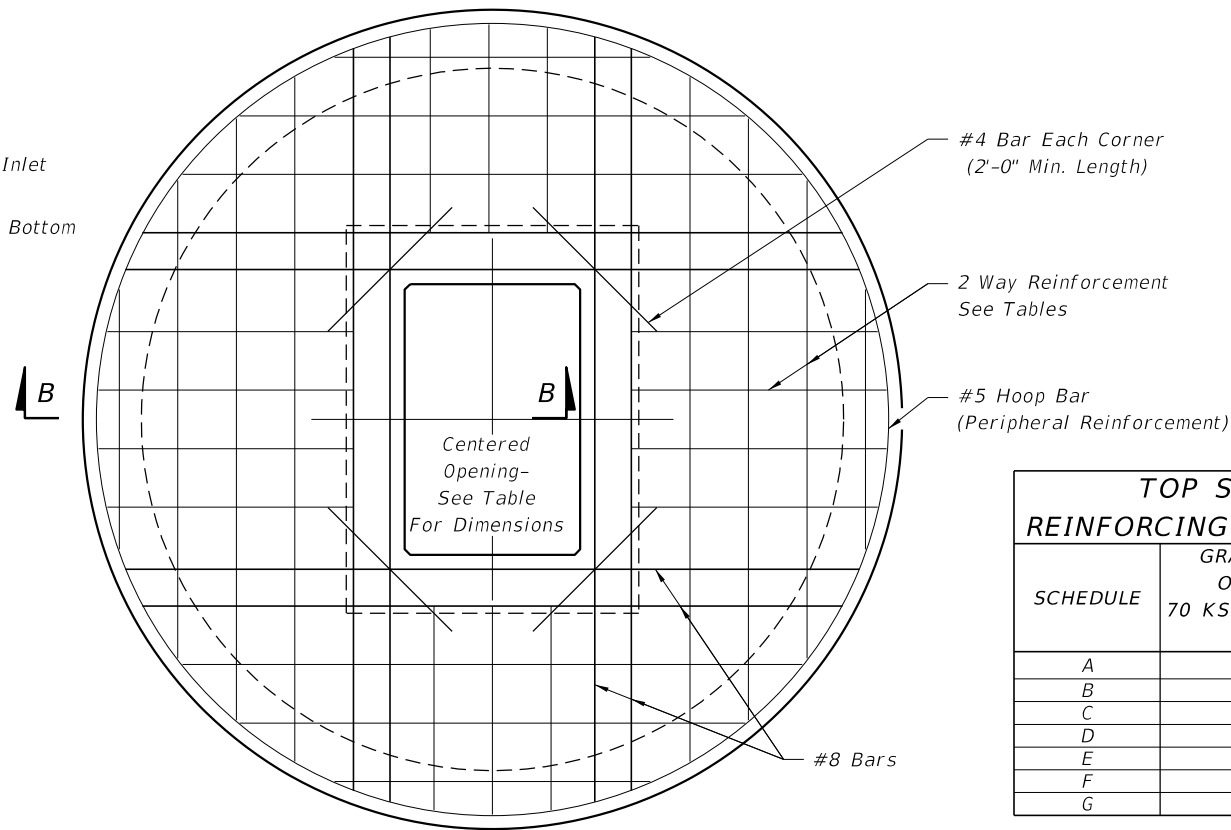

TOP SLAB REINFORCING DIAGRAM

TOP SLAB OPENINGS		
DIAMETER	OPENING SIZE	
	MIN.	MAX.
4'-0"	2'-0" x 3'-1"	2'-0" x 3'-1"
5'-0"	2'-0" x 3'-1"	3'-1" x 4'-1"
6'-0"	2'-0" x 3'-1"	3'-0" x 4'-6"
8'-0"	2'-0" x 3'-1"	3'-0" x 4'-6"

TOP SLAB REINFORCING SCHEDULE	
SCHEDULE	GRADE 60 (BAR) OR 65 KSI & 70 KSI (WIRE FABRIC) In. <sup>2</sup> /ft.
A	0.20
B	0.24
C	0.37
D	0.53
E	0.73
F	1.06
G	1.45

TOP SLAB WITH CENTERED OPENING		
SLAB DEPTH	SLAB THICKNESS	REINFORCING (2 WAYS) SCHEDULE
SIZE: 4'-0"		
≥0.5'-40'	9½"	C
SIZE: 5'-0"		
≥0.5' < 30'	9½"	C
30'-40'	9½"	D
SIZE: 6'-0"		
0.5' < 8'	9½"	B
8' < 18'	9½"	C
18' < 30'	9½"	D
30' < 37'	9½"	E
37'-40'	9½"	G
SIZE: 8'-0"		
≥0.5' < 9'	11½"	C
9' < 15'	11½"	D
15' < 23'	11½"	E
23' < 33'	11½"	E
33'-40'	11½"	G

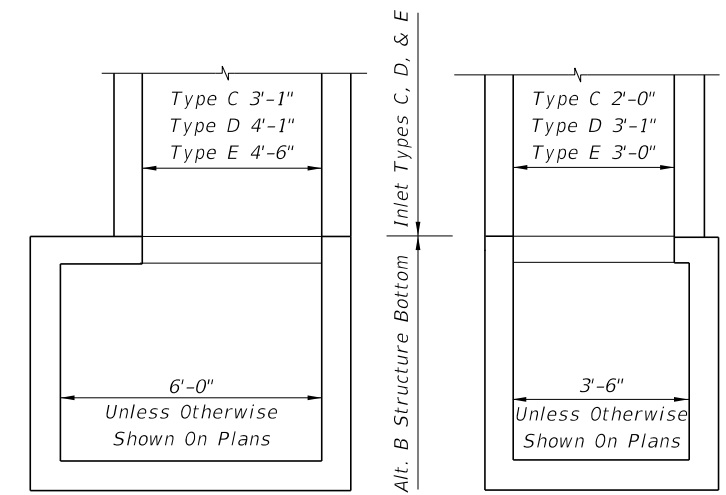

See Index No. 200 for structure bottom details and hole reinforcement.

ALT. B STRUCTURE BOTTOM FOR INLETS TYPE C, D & E

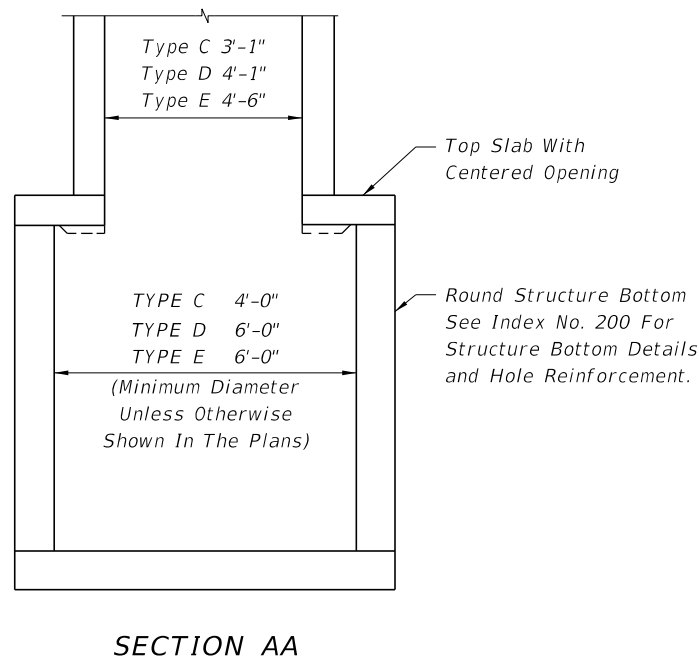

SECTION AA

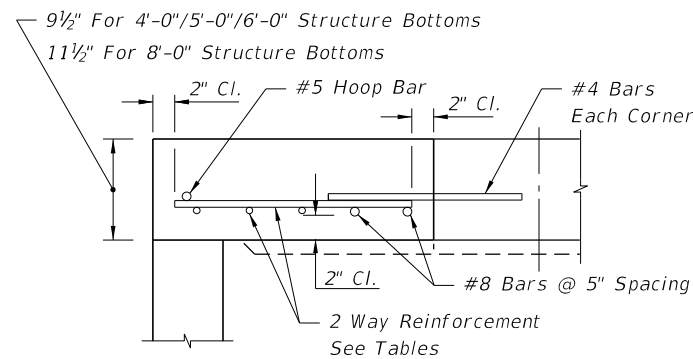

SECTION BB

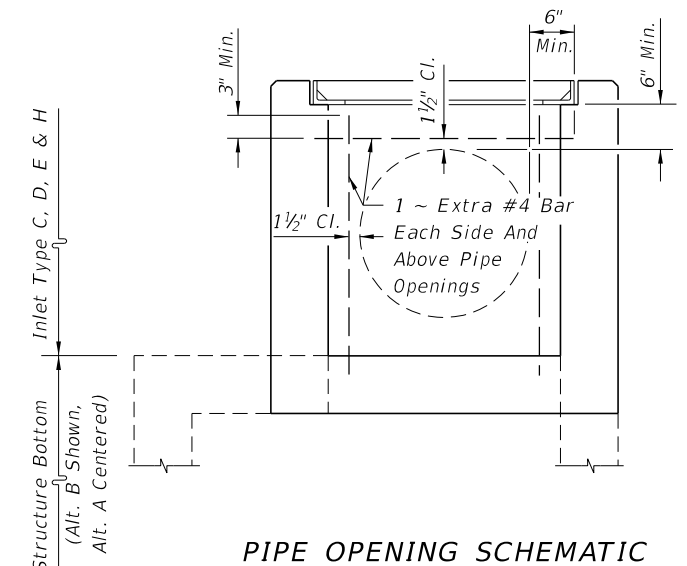

PIPE OPENING SCHEMATIC

ALT. A STRUCTURE BOTTOM FOR INLETS TYPE C, D AND E

12/30/2011 11:39:32 AM r0960/h C:\projects\standards\roadway\0200-s\020232-07.dgn

LAST REVISION 07/01/05	DESCRIPTION:	 <b>FDOT DESIGN STANDARDS</b> FY 2012/2013	DITCH BOTTOM INLET TYPES C, D, E AND H		INDEX NO. 232	SHEET NO. 7
REVISION						