

NOTE: Alt. B Structure Bottom Only. See Index No. 200 for structure bottom details and hole reinforcement.  
(For Pipes 30" Dia. And Larger)  
**INLET WITH STRUCTURE BOTTOM**

**RECOMMENDED MAXIMUM PIPE SIZES**

Inlet Inside Width	Pipe Size
2'-11" Or 3'-3"	24"
4'-0" Or 3'-10"	30"

Note: Recommended sizes are for concrete pipe. Sizes for other types of pipe must be verified for fit in accordance with Index No. 201. For larger pipe see bottom detail above and Index No. 200.

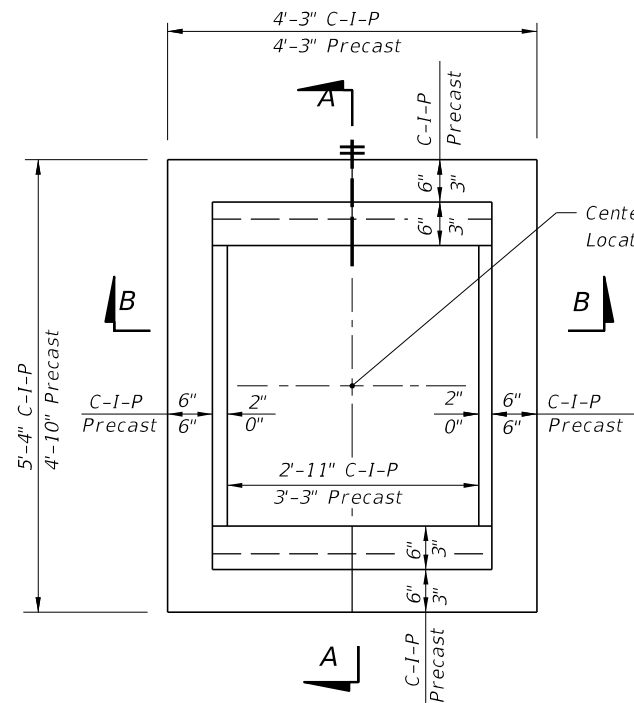

**PLAN**  
(CAST-IN-PLACE INLET SHOWN WITHOUT GRATE; PRECAST INLET SIMILAR)

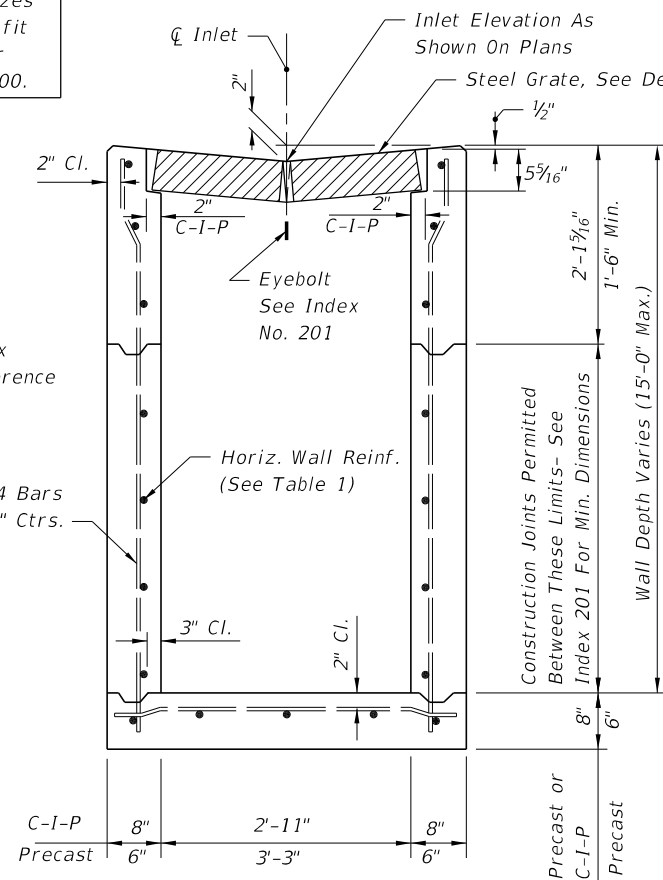

**SECTION BB**  
(CAST-IN-PLACE INLET SHOWN PRECAST INLET SIMILAR)

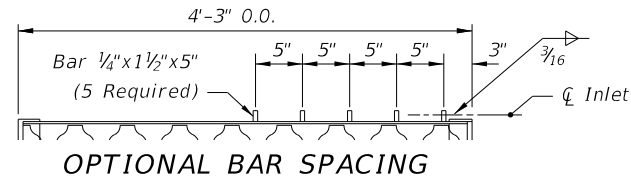

**OPTIONAL BAR SPACING**

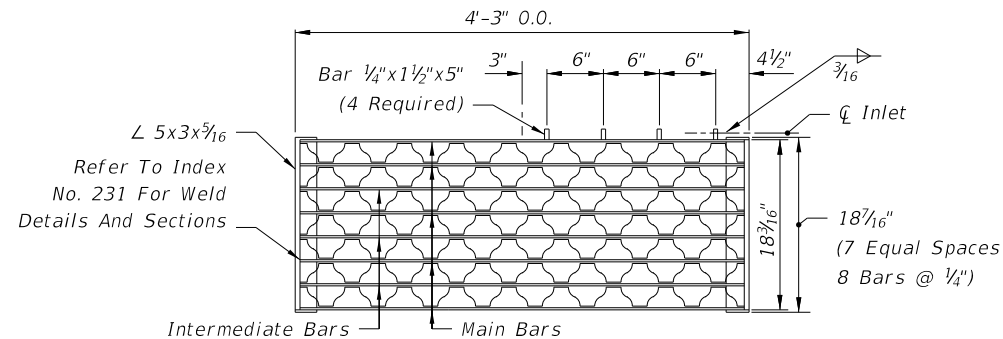

**TWO REQUIRED PER INLET**

5" Steel Grate: Main Bars 5"x1/4"  
Intermediate Bars 1 1/2"x1/4"  
Reticuline Bars 1 1/4"x3/16"

Steel Grate: Manufactured By Borden, Florida Steel, U.S.  
Foundry Irving, Reliance, Greulich (Or Equal).

**STEEL GRATE**

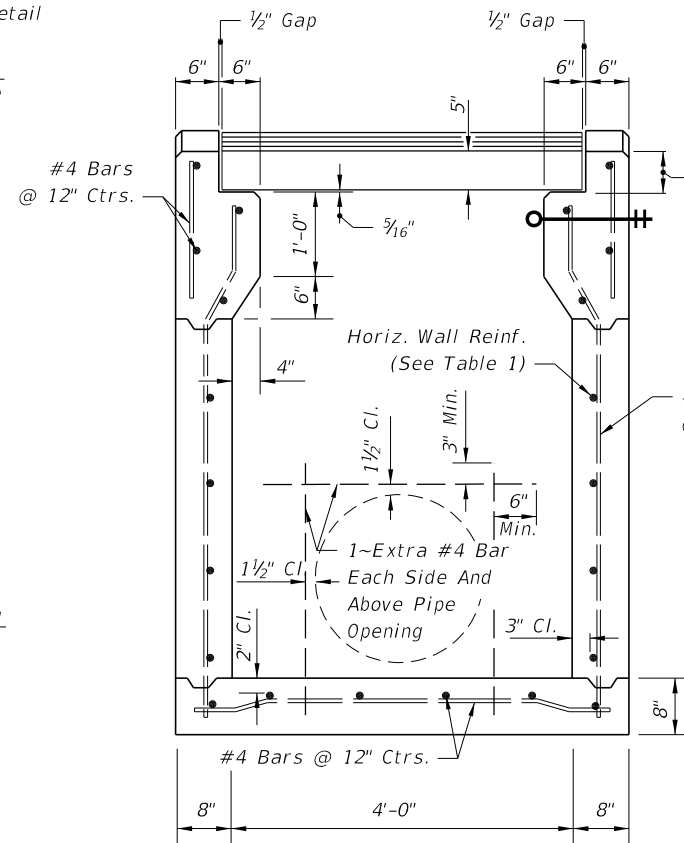

**SECTION AA**  
(CAST-IN-PLACE INLET)

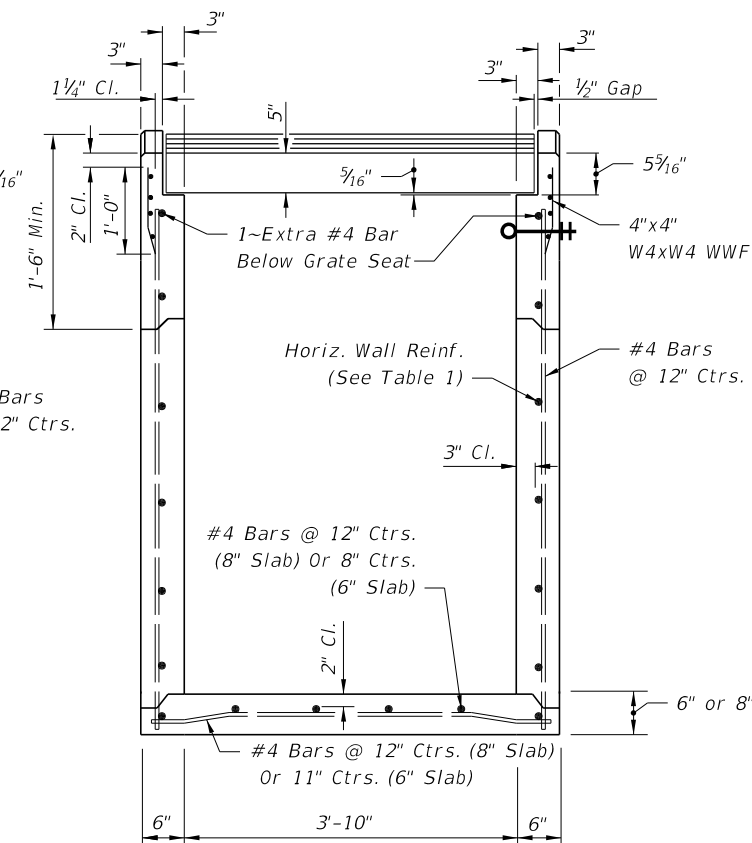

**SECTION AA**  
(PRECAST INLET)

**GENERAL NOTES**

1. This inlet is suitable for village swales, ditches, or other areas subject to heavy wheel loads, minimum debris. This inlet may be placed in areas subject to occasional pedestrian traffic such as landscaped areas and pavement areas where pedestrians can walk around the inlet. This inlet is not for use in a bicycle way.
2. When alternate "G" grate is specified in plans, the grate is to be hot dip galvanized after fabrication.
3. All reinforcing is Grade 60 bars with 2" min. cover unless otherwise noted. See Index No. 201 for equivalent area of welded wire fabric. Cut or bend bars out of way of pipe to clear pipe 1 1/2".
4. All exposed edges and corners shall be 3/4" chamfer or tooled to 1/4" radius.
5. All dimensions are for both precast and cast-in-place inlets unless otherwise noted.
6. For supplementary details see Index No. 201.
7. Inlet to be paid for under the contract unit price for Inlets (Gutter Type V), EA

**HORIZONTAL WALL REINFORCING SCHEDULE (TABLE 1)**

WALL DEPTH	SCHEDULE	AREA (in. <sup>2</sup> /ft.)	MAX. SPACING	
			BARS	WWF
0' - 5'	A12	0.20	12"	8"
5' - 9'	A6	0.20	6"	5"
9' - 12'	A4	0.20	4"	3"
9' - 15'	B5.5	0.24	5 1/2"	5"

C:\projects\standards\roadway\0200-s\0221-01.dgn  
r0960/h  
11:39:24 AM  
12/30/2011

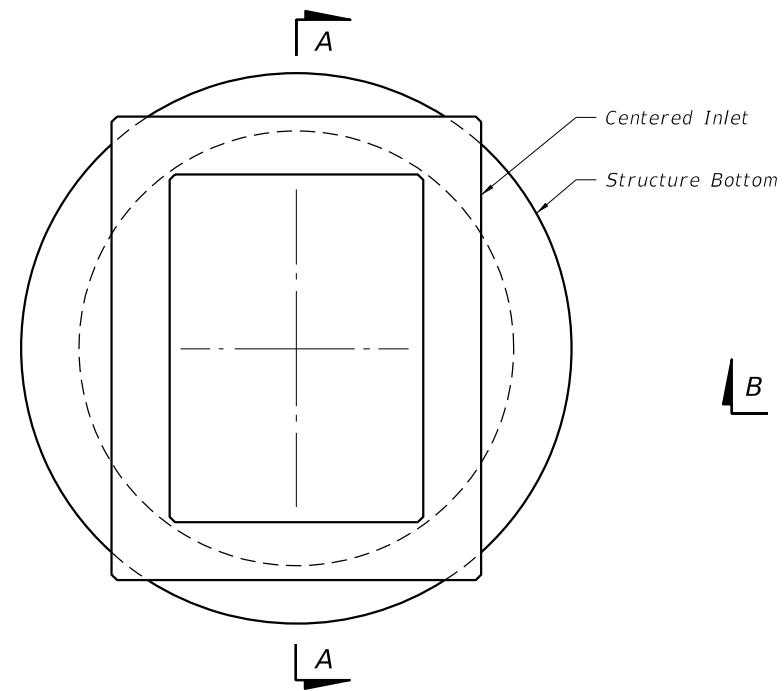

TOP SLAB OPENINGS		
DIAMETER	OPENING SIZE	
	MIN.	MAX.
5'-0" To 8'-0"	2'-11" x 4'-0"	3'-3" x 3'-10"

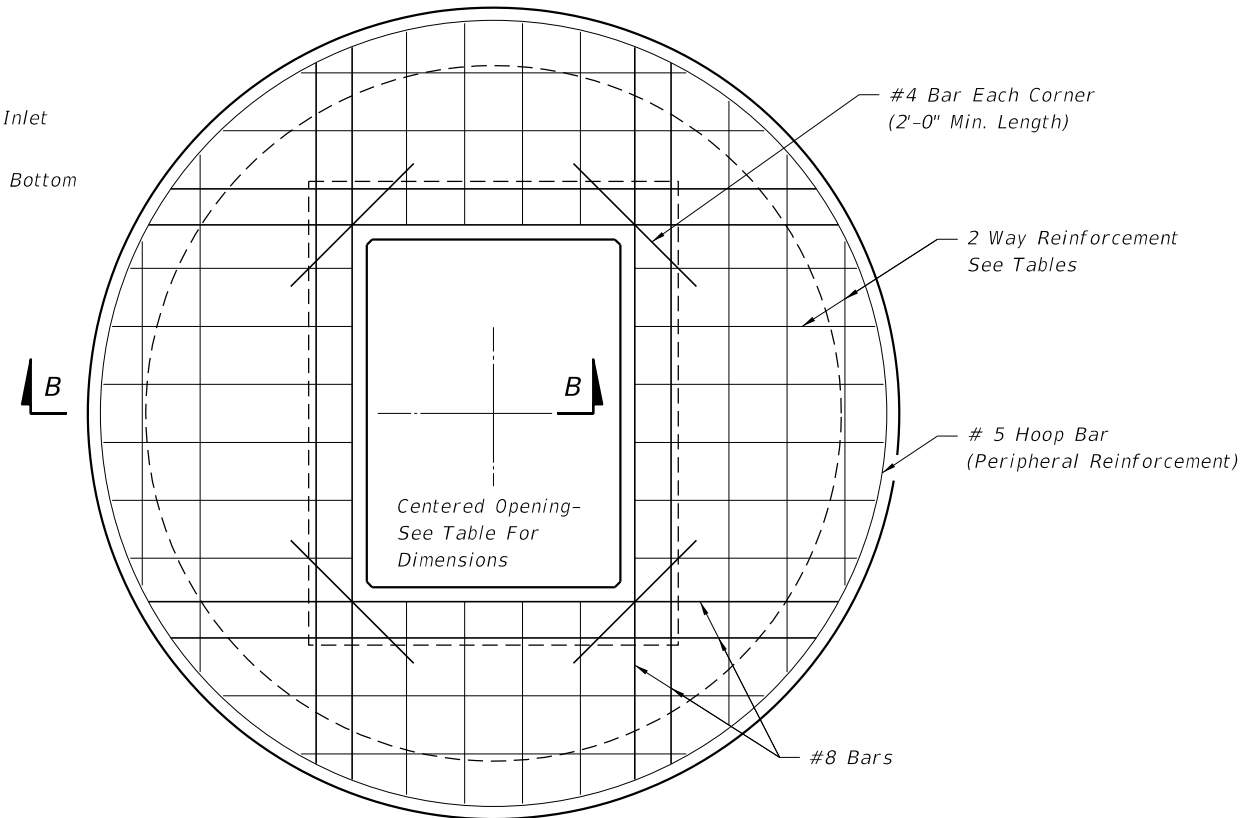

TOP SLAB REINFORCING DIAGRAM

TOP SLAB REINFORCING SCHEDULE	
SCHEDULE	GRADE 60 (BAR) OR 65 KSI & 70 KSI (WIRE FABRIC) In. <sup>2</sup> /ft.
	A
B	0.24
C	0.37
D	0.53
E	0.73
F	1.06
G	1.45

TOP SLAB WITH CENTERED OPENING		
SLAB DEPTH	SLAB THICKNESS	REINFORCING (2 WAYS) SCHEDULE
SIZE: 5'-0"		
≥0.5' < 30'	9½"	C
30'-40'	9½"	D
SIZE: 6'-0"		
0.5' < 8'	9½"	B
8' < 18'	9½"	C
18' < 30'	9½"	D
30' < 37'	9½"	E
37'-40'	9½"	G
SIZE: 8'-0"		
≥0.5' < 9'	11½"	C
9' < 15'	11½"	D
15' < 23'	11½"	E
23' < 33'	11½"	E
33'-40'	11½"	G

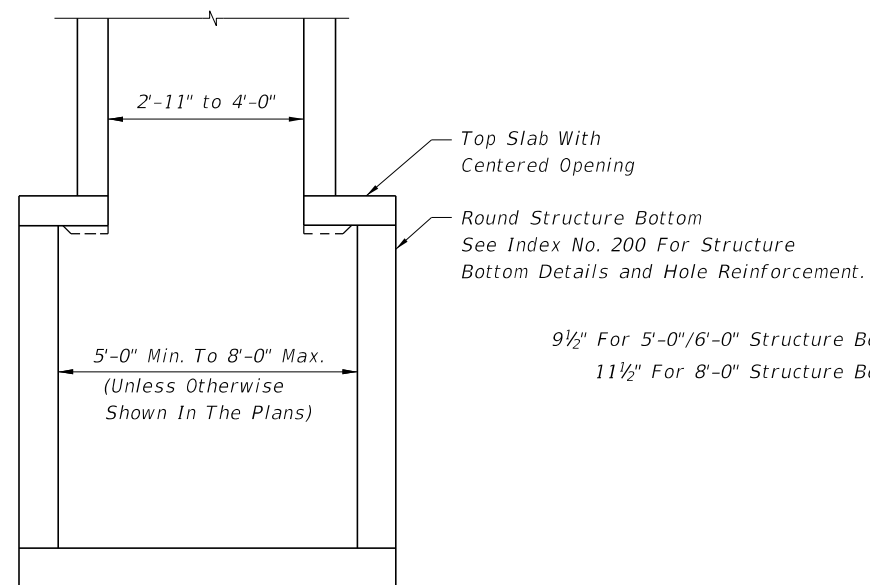

SECTION AA

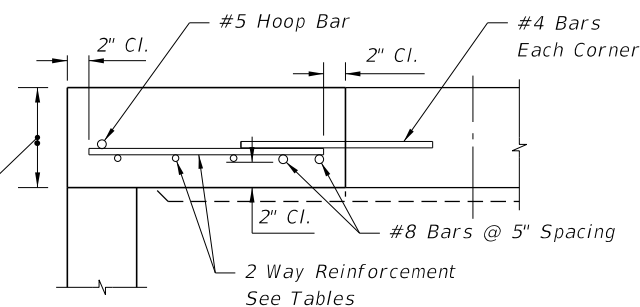

SECTION BB

9½" For 5'-0"/6'-0" Structure Bottoms  
11½" For 8'-0" Structure Bottoms

ALT. A STRUCTURE BOTTOM FOR INLET TYPE V

12/30/2011 11:39:24 AM r1960/h C:\projects\standards\roadway\0200-s\0221-02.dgn

LAST REVISION 0701/05	DESCRIPTION:	 FDOT DESIGN STANDARDS FY 2012/2013	GUTTER INLET TYPE V	INDEX NO. 221	SHEET NO. 2
--------------------------	--------------	---	---------------------	------------------	----------------