

☐ Inlet
Symmetrical About ☐ For Inlet Types 2 & 4 and for Double Throat Side of Inlet Type 5. See Tabular Description of Inlets, General Note 1.

GRATE SLOPE & DROP HEIGHT				
Shoulder Slope	Grate Slope Rate	Drop Height		Remarks
		CIPL	Precast	
0.03	1:6	1 1/16"	1 1/16"	Std. Median Concrete Shoulder
0.05	1:6	1 1/16"	7/8"	Std. Median Flexible Shoulder
0.06	1:6	1 3/16"	5/8"	
0.07	1:5	1 5/8"	1 3/8"	
0.08	1:5	1 3/8"	1 3/16"	
0.09	1:5	1 1/8"	1 5/16"	
0.10	1:5	7/8"	1 1/16"	e (max)

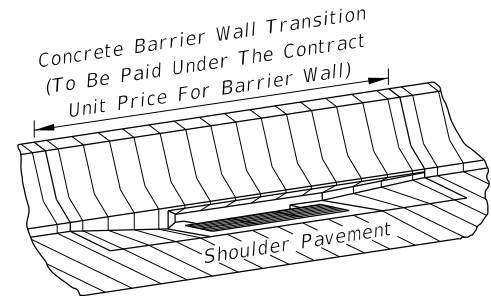

PICTORIAL VIEW (TYPE 1 SHOWN)

GENERAL NOTES

- Inlet Descriptions:**
Type 1 Single throat, one side of barrier wall.
Type 2 Double throats, one side of barrier wall.
Type 3 Two single throats, opposite side of barrier wall.
Type 4 Two double throats, opposite sides of barrier wall.
Type 5 Double throats, one side of barrier wall, and single throat other side of barrier wall.
- For grate details see Index No. 220. The parallel bar grate shall be used unless the reticuline grate is called for in the plans. The reticuline grate shall be specified where bicycle traffic is anticipated. Used in areas of occasional pedestrian traffic. Not suitable for use in pedestrian traffic or bicycle way.
- All exposed edges and corners shall be 3/4" chamfer or tooled to 1/4" radius.
- For standard concrete barrier wall dimensions, and for dimensions of concrete barrier wall incorporating light standards within the wall, see Index No. 410.
- Reinforcing steel shall have 2" minimum cover. Horizontal wall reinforcing must be positioned 3" from the inside face unless otherwise shown.
- All reinforcing is Grade 60 #4 bars. See Index No. 201 for equivalent area of welded wire fabric for inlet. Longitudinal steel bars extend over full length of concrete barrier wall transition. Tie bars @ 12" ctrs. Reinforcing to be paid for under the contract unit price for Concrete Barrier Wall, LF.
- For supplemental details see Index No. 201.
- All dimensions are for both precast and cast-in-place inlets unless otherwise noted.
- Inlets to be paid for under the contract unit price for Inlets (Median Barrier Type), EA. Barrier wall to be paid for under the contract unit price for Concrete Barrier Wall, LF.

HORIZONTAL WALL REINFORCING SCHEDULE (TABLE 1)

WALL DEPTH	SCHEDULE	AREA (in. ² /ft.)	MAX. SPACING	
			BARS	WWF
0'-3'	A12	0.20	12"	8"
3'-6'	A6	0.20	6"	5"
6'-9'	B5.5	0.24	5 1/2"	5"
9'-15'	C6.5	0.37	6 1/2"	6"

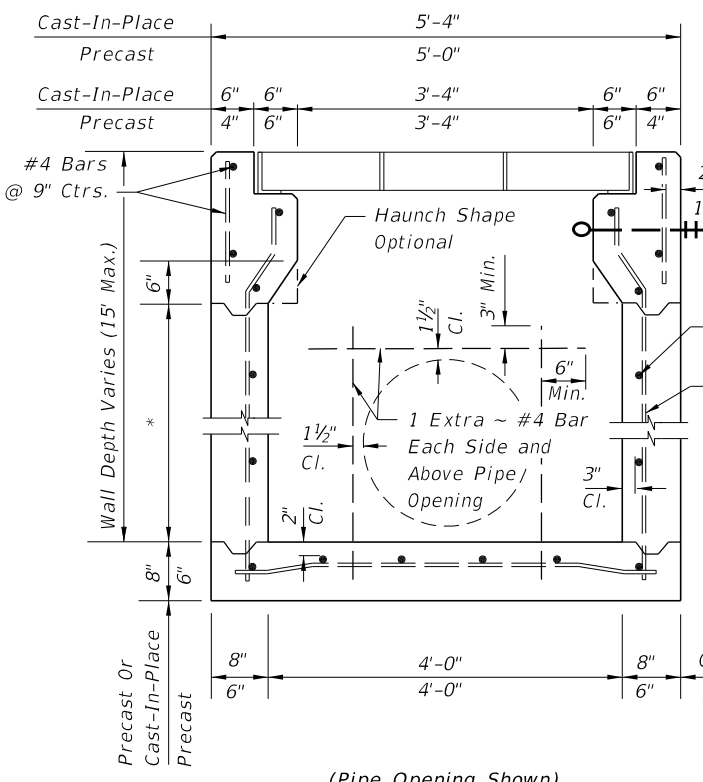
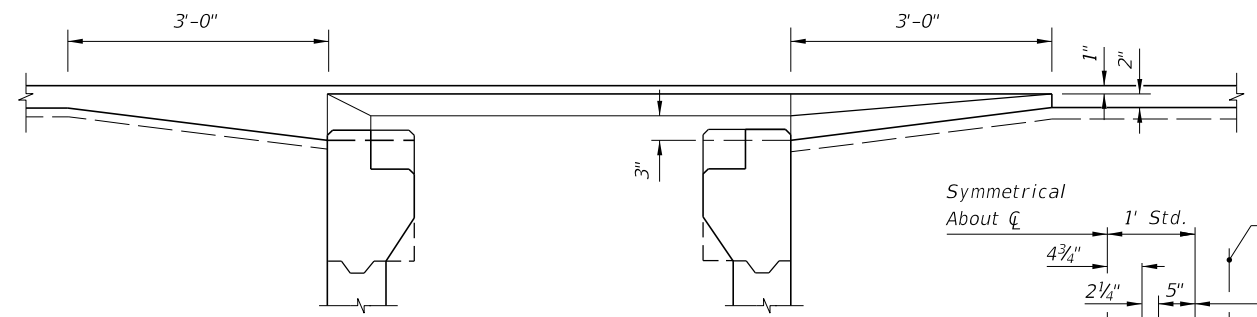
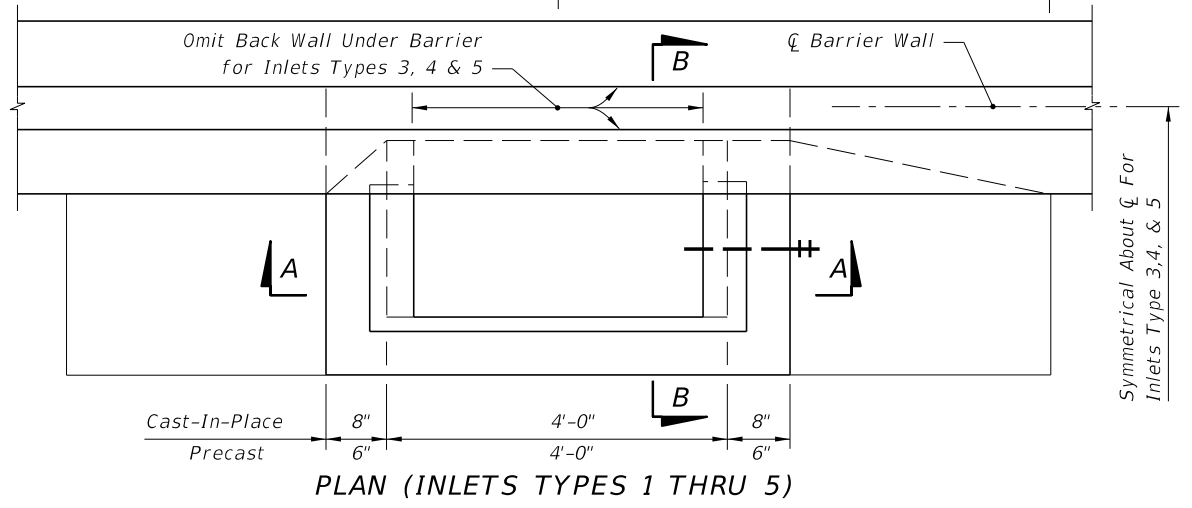

(Pipe Opening Shown)
SECTION AA

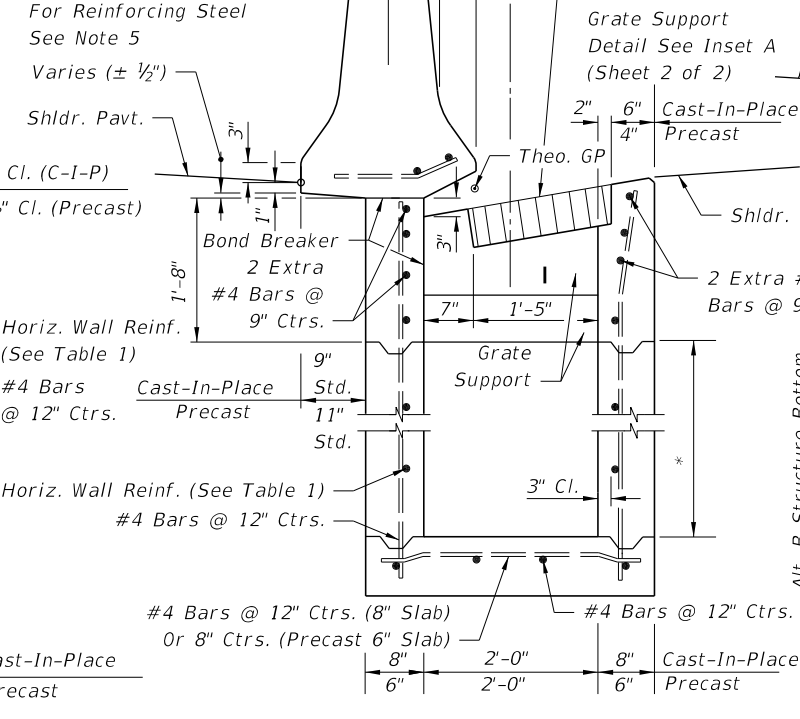

SECTION FOR INLETS TYPES 1 & 2

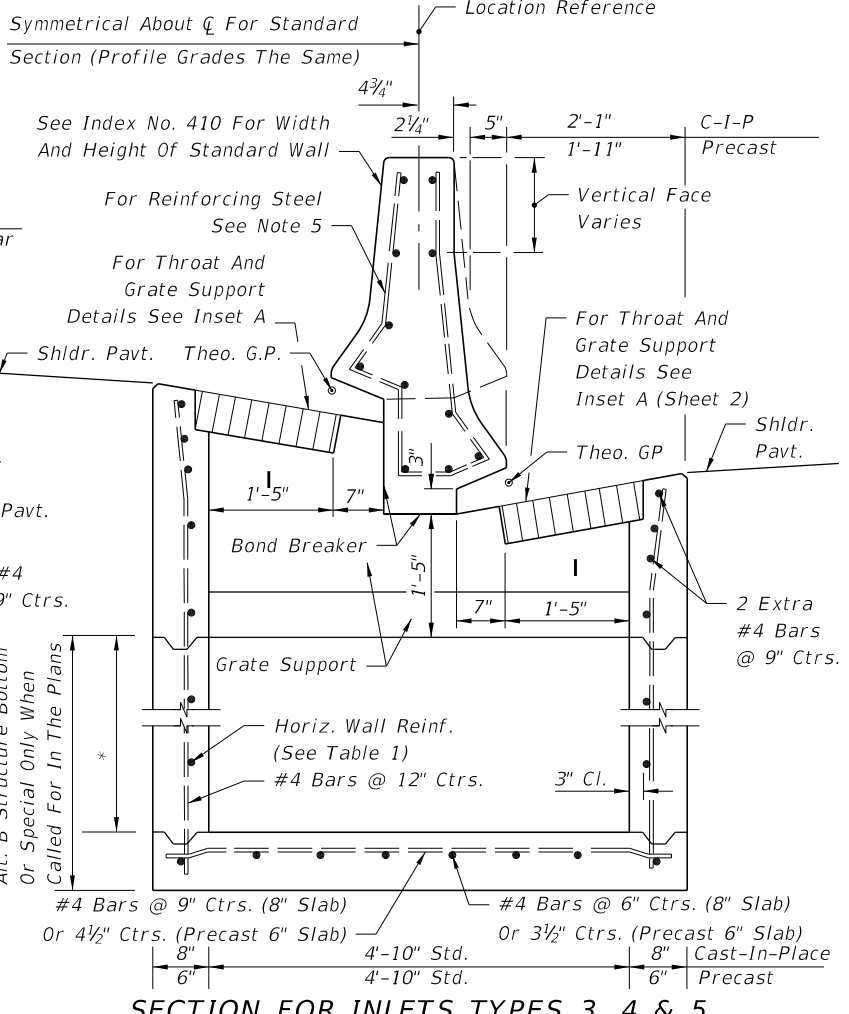

SECTION FOR INLETS TYPES 3, 4 & 5 (NON-SYMMETRICAL SECTION SHOWN)

* Const. Joint Permitted Between These Limits See Index No. 201 For Min. Dimensions

12/30/2011 11:39:15 AM r1960/h C:\projects\standards\roadway\0200-s\0217-01.dgn

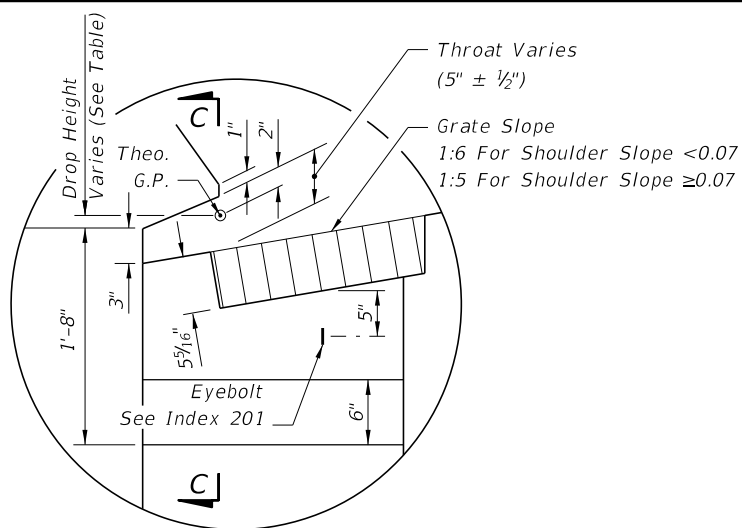

INSET A

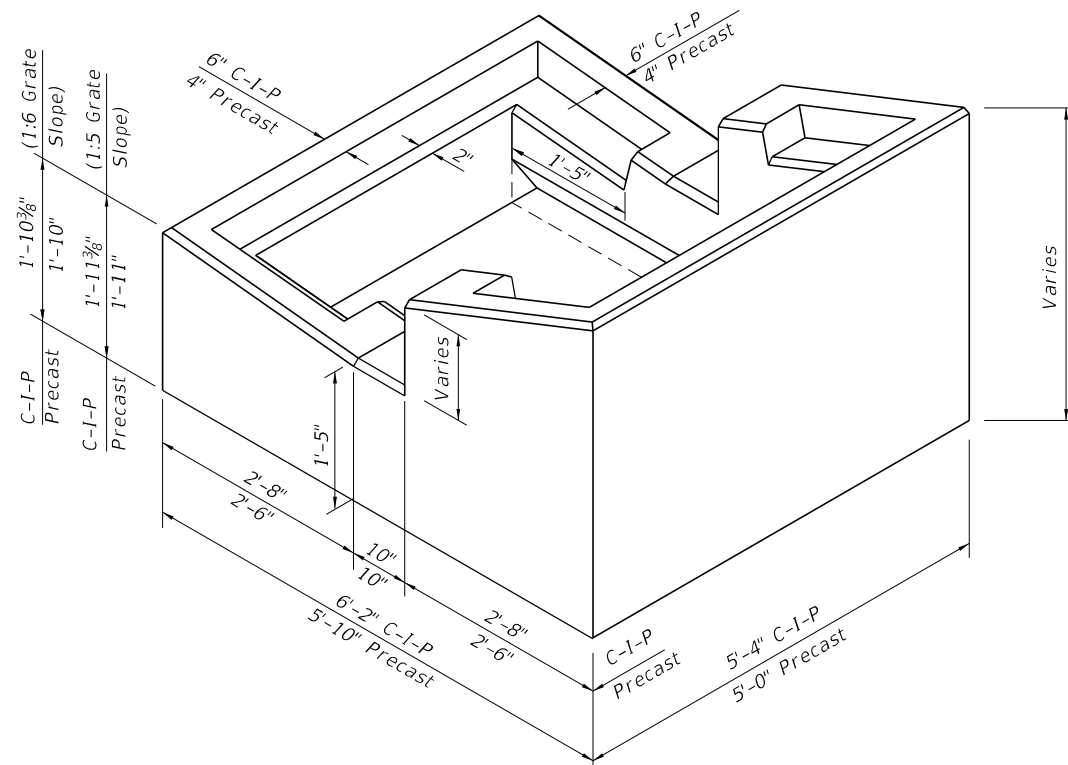

PICTORIAL VIEW OF INLET COLLAR (TYPES 3, 4, & 5)

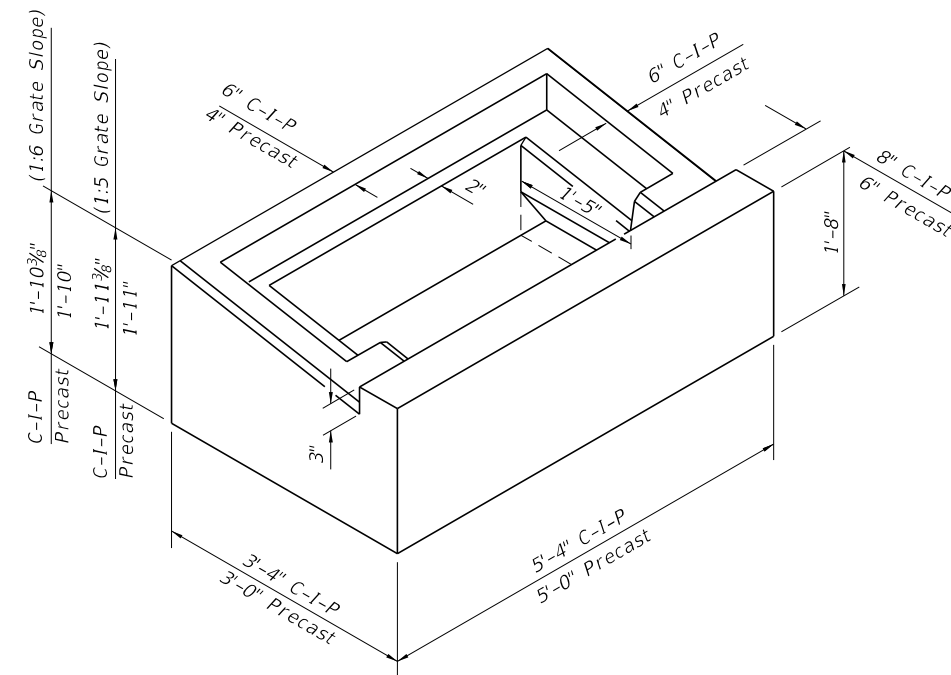

PICTORIAL VIEW OF INLET COLLAR (TYPES 1 & 2)

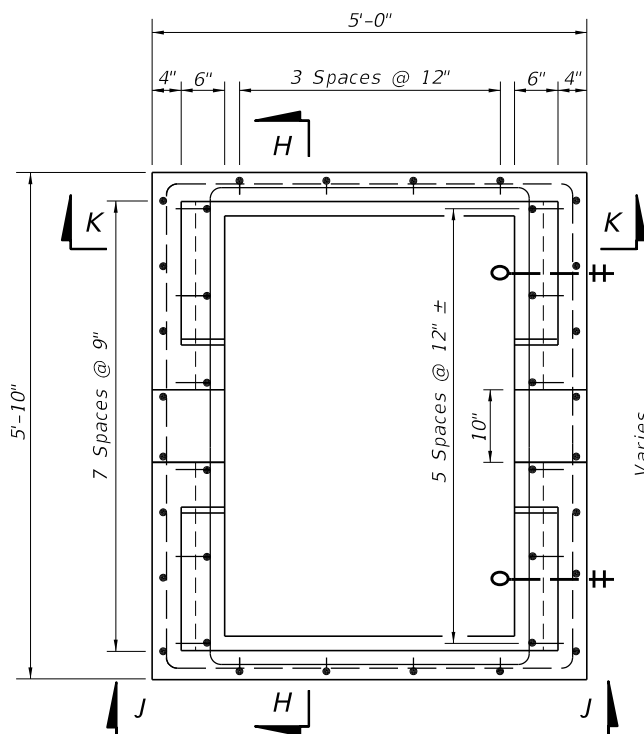

TOP VIEW OF INLET COLLAR WITHOUT GRATE

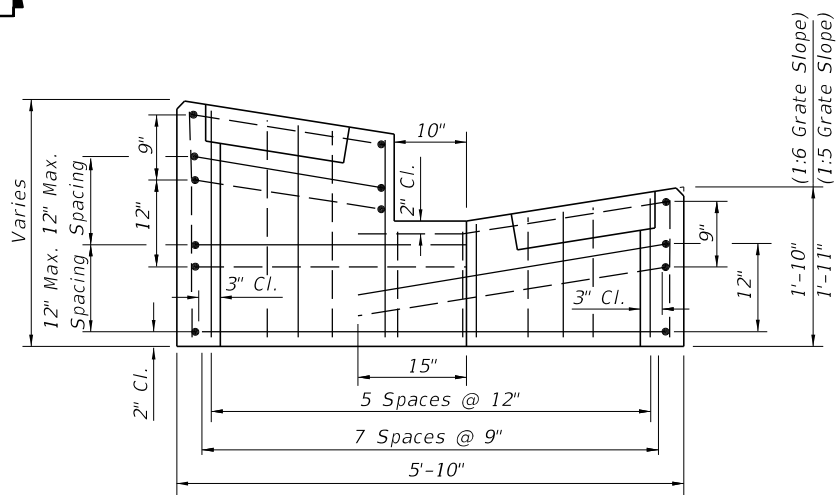

SECTION HH

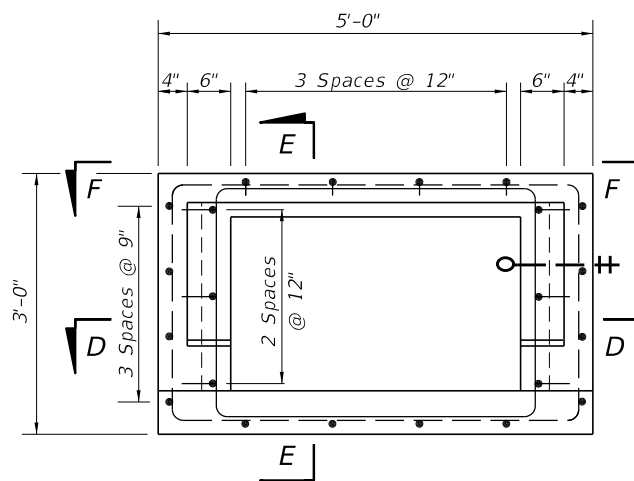

TOP VIEW OF INLET COLLAR WITHOUT GRATE

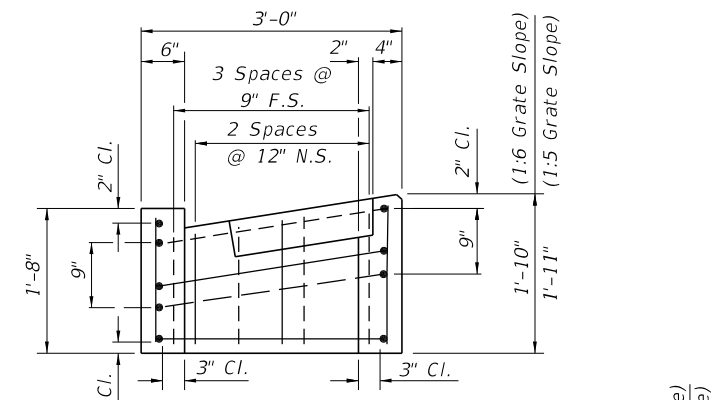

SECTION EE

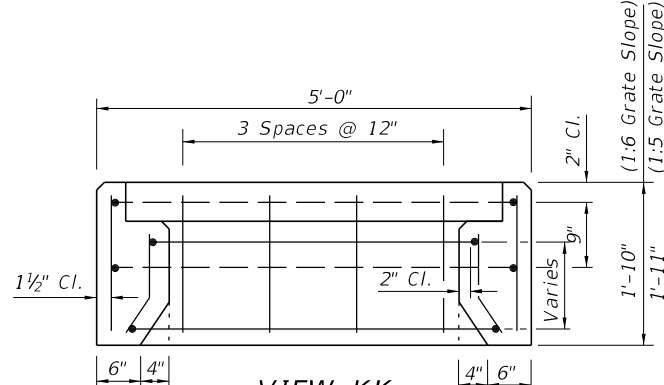

VIEW KK

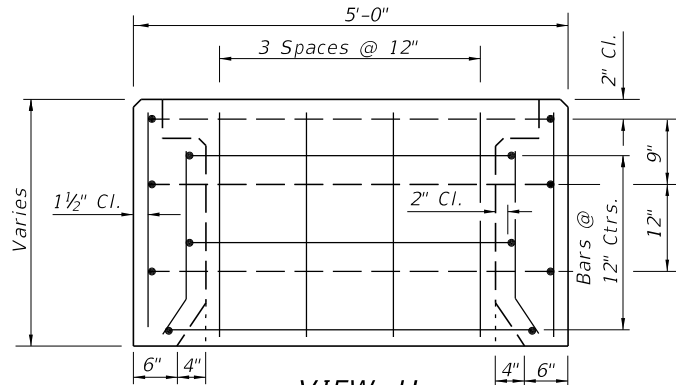

VIEW JJ

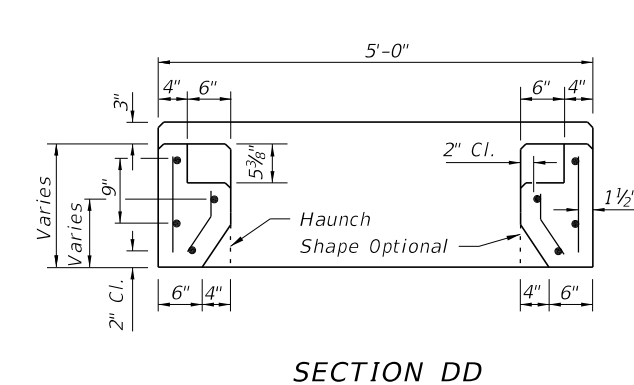

SECTION DD

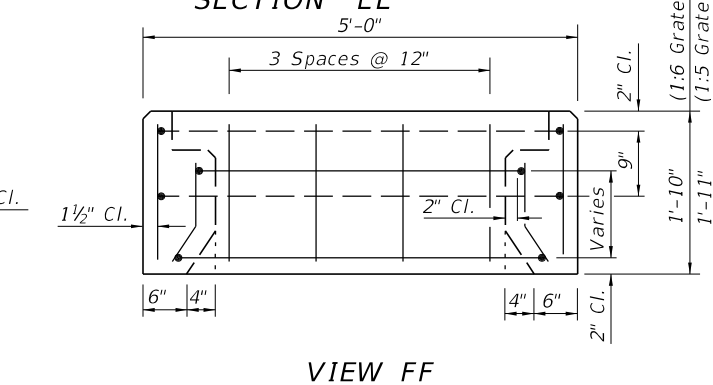

VIEW FF

PRECAST COLLAR REINFORCING DETAILS (TYPES 3, 4 & 5)
(C-I-P COLLAR REINFORCING DETAILS SIMILAR)

PRECAST COLLAR REINFORCING DETAILS (TYPES 1 & 2)
(C-I-P COLLAR REINFORCING DETAILS SIMILAR)

12/30/2011 11:39:16 AM r0960/h C:\projects\standards\roadway\0200-s\02017-02.dgn

LAST REVISION	DESCRIPTION:	 FDOT DESIGN STANDARDS FY 2012/2013	MEDIAN BARRIER INLETS TYPES 1, 2, 3 4 AND 5	INDEX NO.	SHEET NO.
07/01/05				217	2