

TYPICAL PANELS AND POSTS

REVISIONS			
DATE	BY	DESCRIPTION	
01/01/10	CMH	Changed Total Number of Sheets	
07/01/10	CMH	Added optional texture for non-roadway face of wall.	

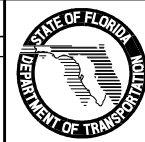

2010 Interim Design Standard  
**PRECAST SOUND BARRIERS**  
 - FLUSH PANEL OPTION

Interim Date: 07/01/10  
 Sheet No.: 1 of 6  
 Index No.: **5202**

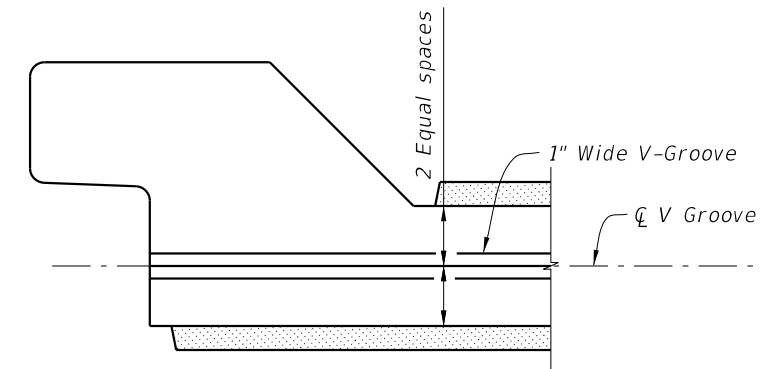
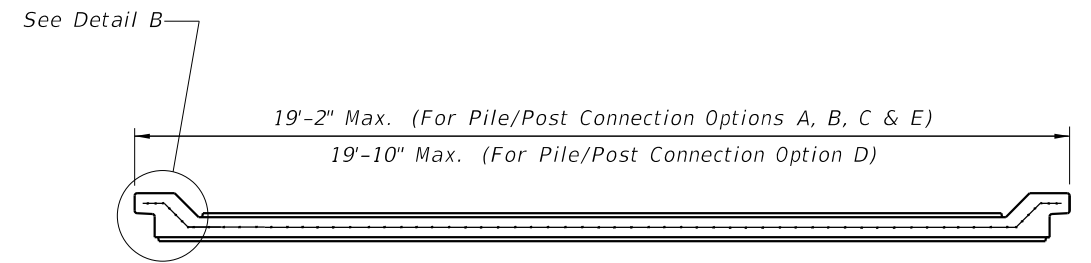
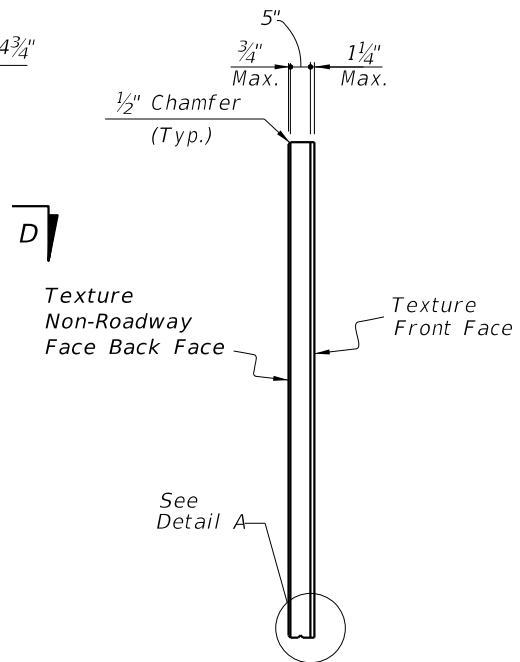
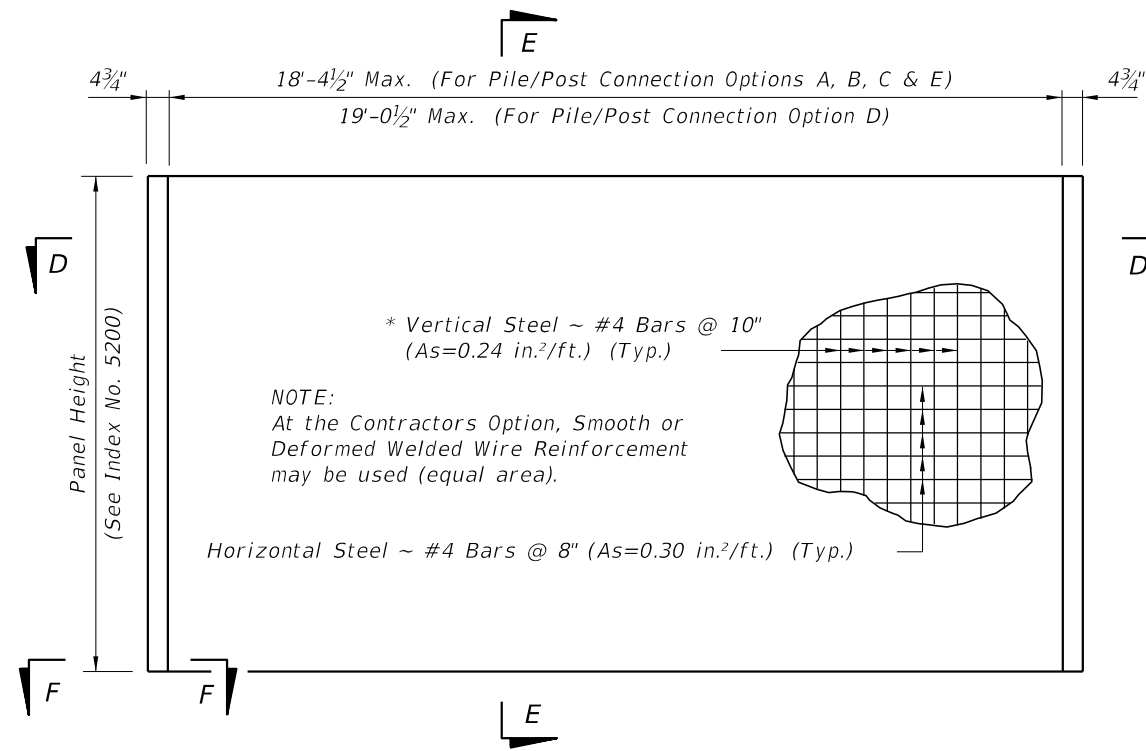

\* In lieu of utilizing the pick up points below, panels may be cast vertically or cast horizontally then tilted upright using tilt-tables prior to lifting from form. In this case, the vertical steel may be reduced to #4 Bars @ 1'-3" (As=0.15 in.<sup>2</sup>/ft.).

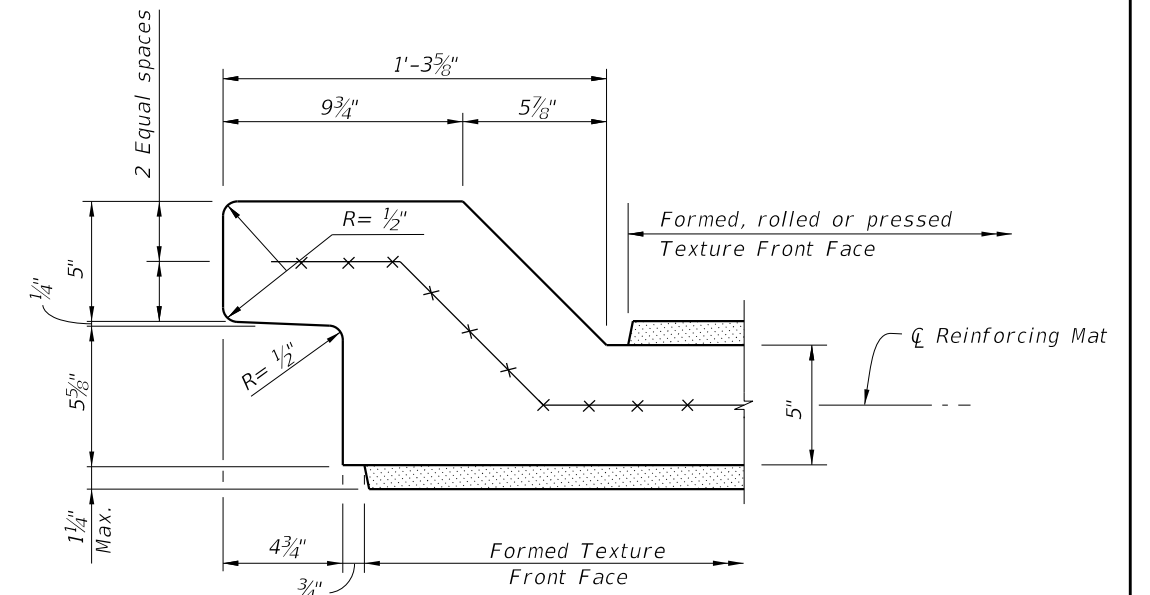
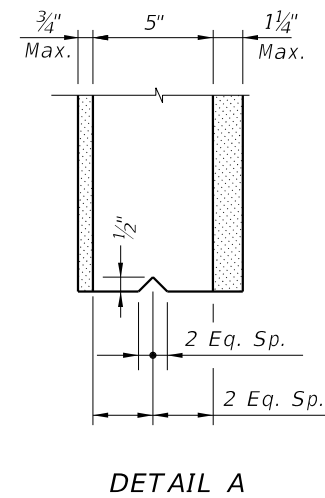
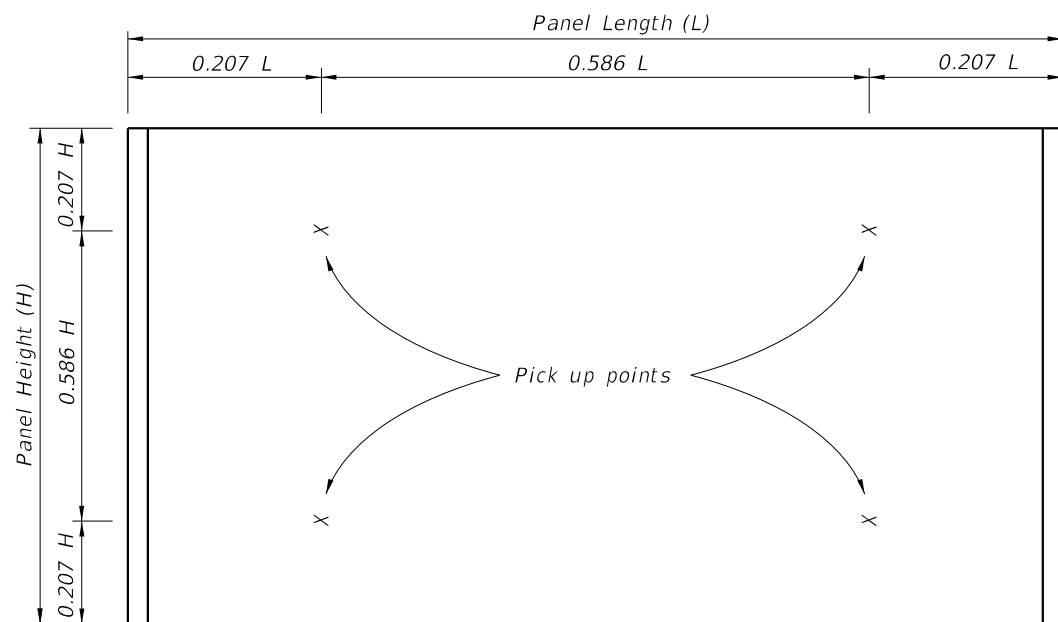

TYPICAL PANELS AND POSTS

REVISIONS					
DATE	BY	DESCRIPTION	DATE	BY	DESCRIPTION
01/01/10	CMH	Changed Total Number of Sheets			
07/01/10	CMH	Added optional texture for non-roadway face of wall.			

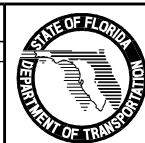

2010 Interim Design Standard  
**PRECAST SOUND BARRIERS**  
- FLUSH PANEL OPTION

Interim Date: 07/01/10  
Sheet No.: 2 of 6  
Index No.: **5202**

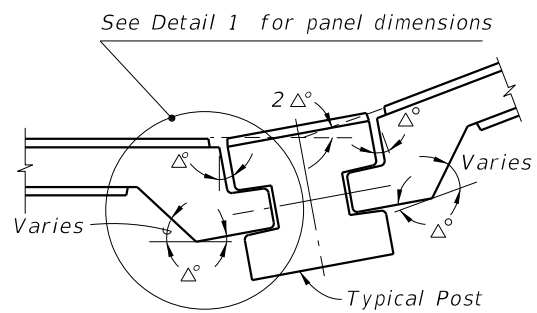

**CASE 1  
(Interior Angle)**

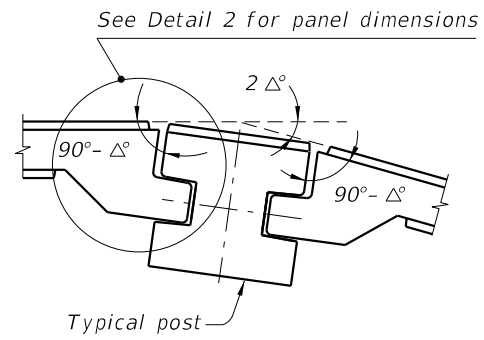

**CASE 2  
(Exterior Angle)**

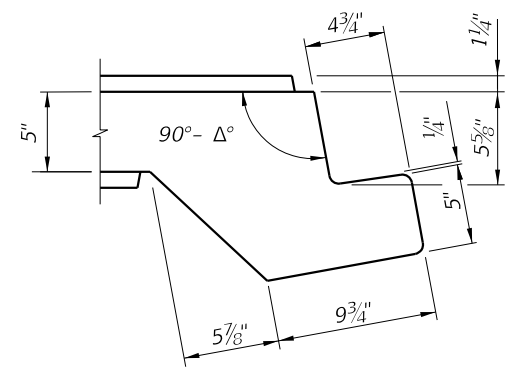

**DETAIL 1**

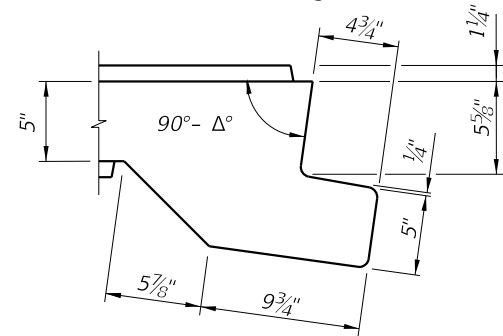

**DETAIL 2**

**PIVOTING POINT DETAILS**

NOTE: The shop drawings shall include specific pivoting point details of panel ends at locations where the deflection angle ( $2\Delta$ ) between panels exceeds  $7^\circ$ .

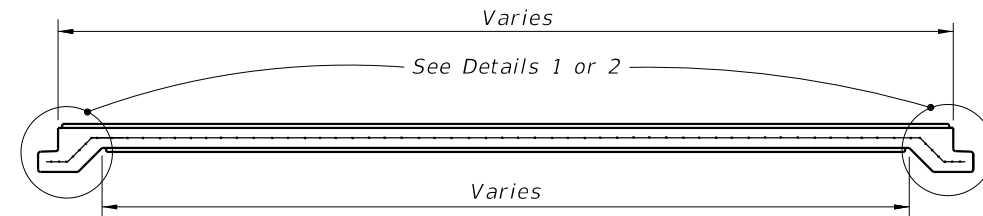

**PANEL PLAN**

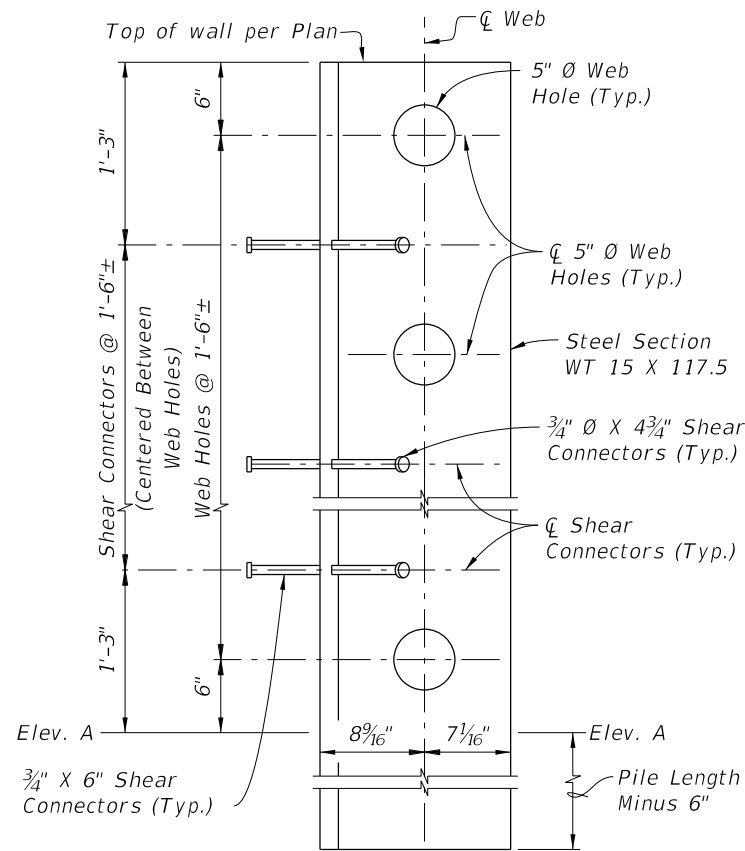

**WEB HOLE & SHEAR CONNECTOR SPACING DETAIL**  
(Concrete not shown for clarity. For limits of concrete see Index No. 5205, Sheet No. 4 of 7.)

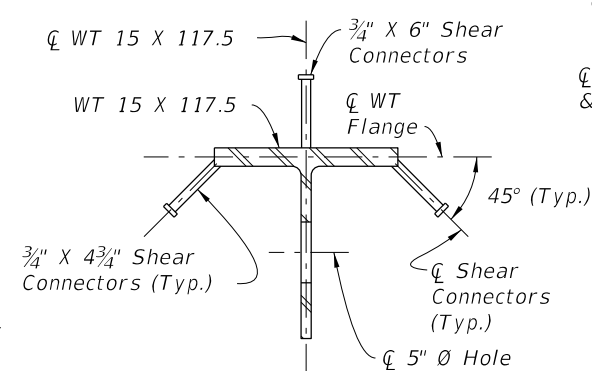

**WT 15 X 117.5 Post Detail For Pile/Post Connection Options C & D**

NOTE: The WT 15 X 117.5 Section shall extend into the Auger Cast Pile.

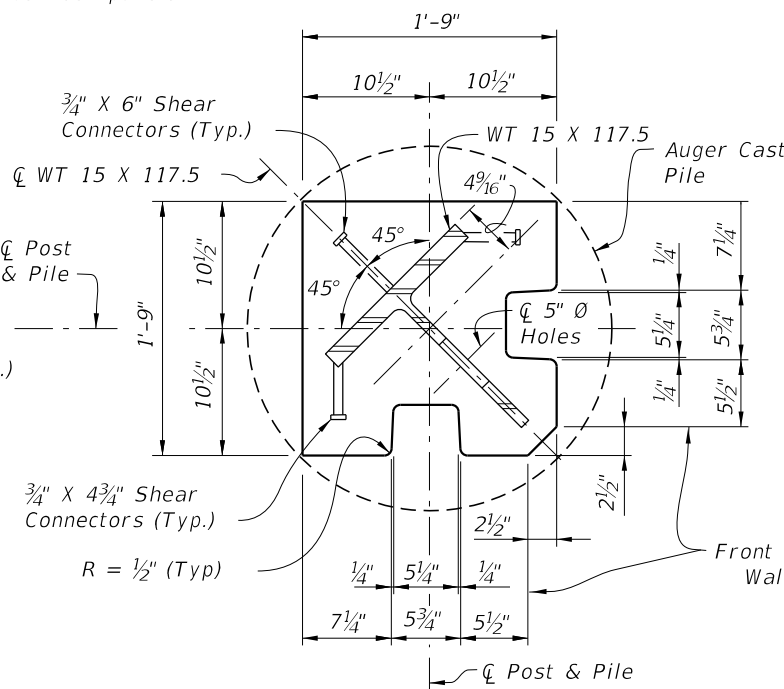

**SPECIAL POSTS FOR 90° CORNERS FOR PILE/POST CONNECTION OPTIONS C & D**  
Collars for Special Posts shall be 3'-6" Ø

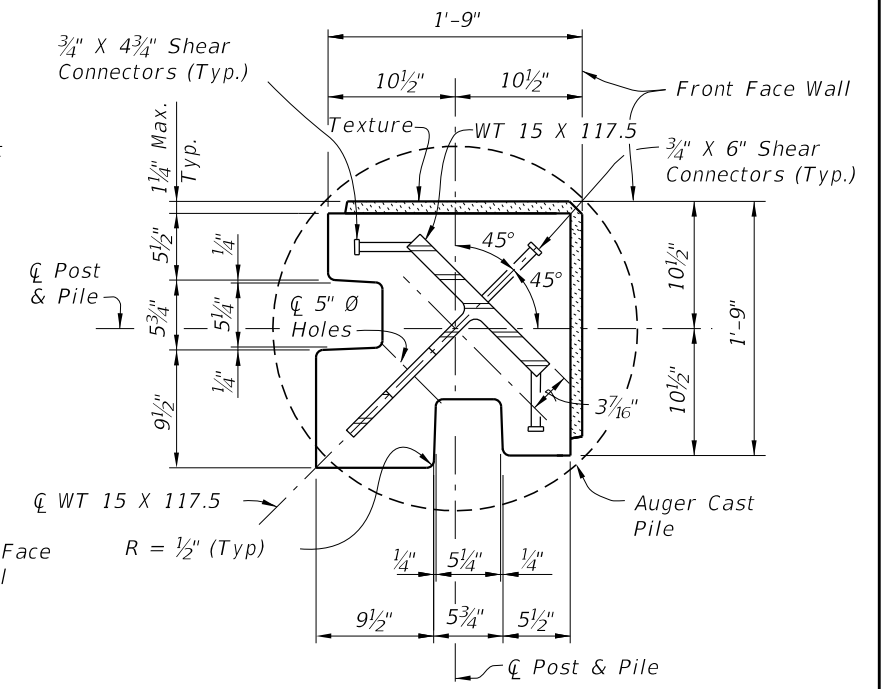

- NOTES:
- For Pile/Post Connection Options C & D, see Index No. 5205.
  - For Post & Pile Lengths, see Index No. 5206.

**SPECIAL PANELS AND POSTS**

REVISIONS			
DATE	BY	DESCRIPTION	
01/01/10	CMH	Removed Special Posts for 90° Corners Options A, B & E. Changed Total Number of Sheets. Revised Notes.	
07/01/10	CMH	Added optional texture for non-roadway face of wall.	

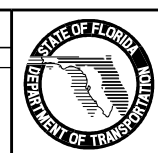

2010 Interim Design Standard

**PRECAST SOUND BARRIERS  
- FLUSH PANEL OPTION**

Interim Date: 07/01/10  
Sheet No.: 3 of 6  
Index No.: **5202**

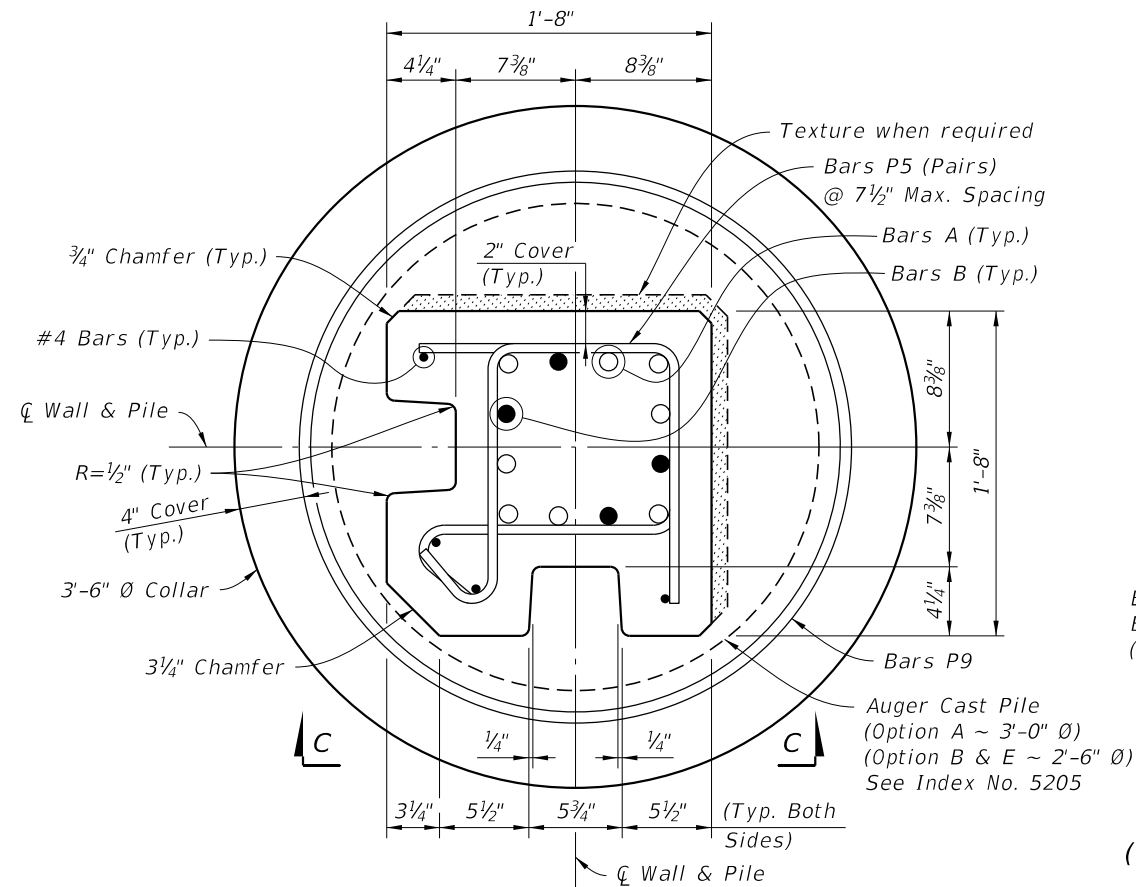

**SECTION A-A**  
TYPICAL SECTION ABOVE PILE

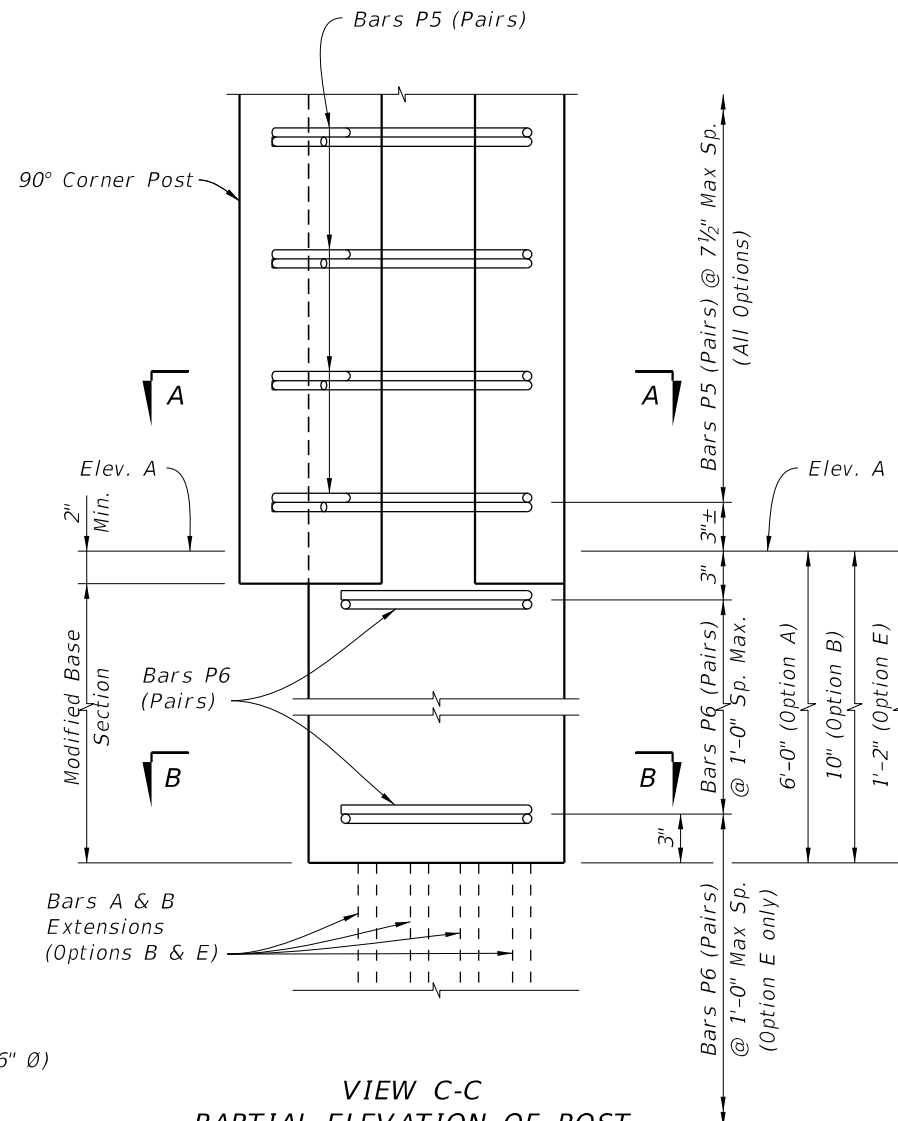

**VIEW C-C**  
PARTIAL ELEVATION OF POST  
(Vertical Reinforcing & Pile not shown for clarity)

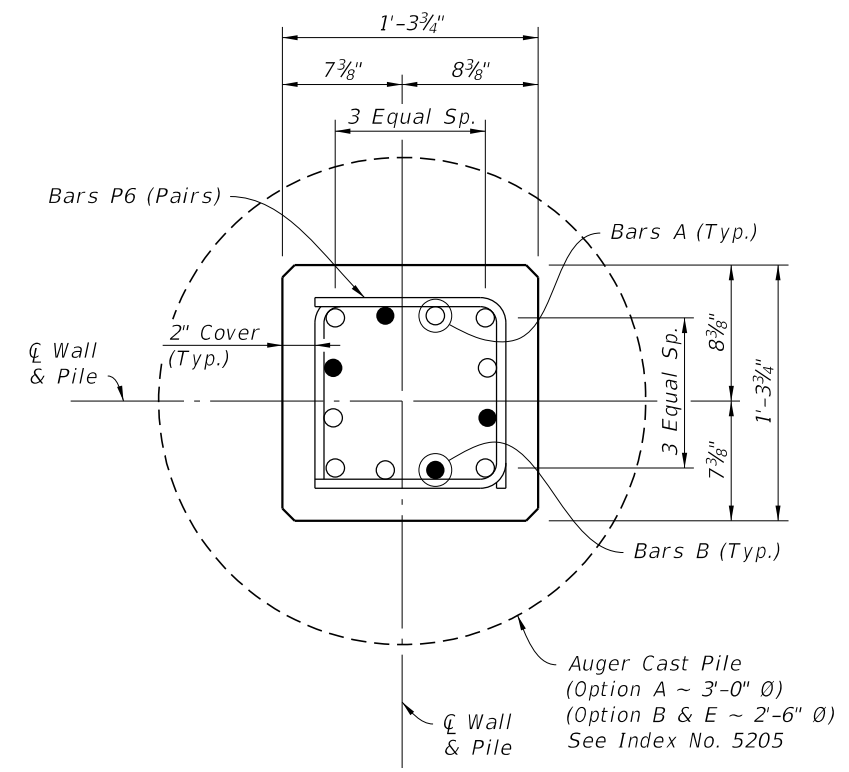

**SECTION B-B**  
(Modified Base Section)

**SPECIAL POSTS FOR 90° CORNERS FOR PILE/POST CONNECTION OPTIONS A, B & E**  
Collars for Special Posts shall be 3'-6" Ø

- NOTES:**
1. For Pile/Post Connection Options A, B & E, see Index No. 5205.
  2. Use 3'-6" CIP Collar for all 90° corner posts.
  3. For Post & Pile Lengths, see Index No. 5206.
  4. For Table of Reinforcing Steel, see Index No. 5206. Bars P10 not required for corner pile.
  5. Reduce standard panel length or adjust post spacing by 3 1/2" at each 90° Corner Post to accommodate the Special Post dimensions.

SPECIAL 90° CORNER POST

REVISIONS					
DATE	BY	DESCRIPTION	DATE	BY	DESCRIPTION
01/01/10	CMH	New Sheet			
07/01/10	CMH	No Change			

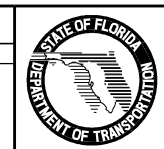

2010 Interim Design Standard  
**PRECAST SOUND BARRIERS**  
- FLUSH PANEL OPTION

Interim Date	Sheet No.
07/01/10	4 of 6
Index No.	
<b>5202</b>	

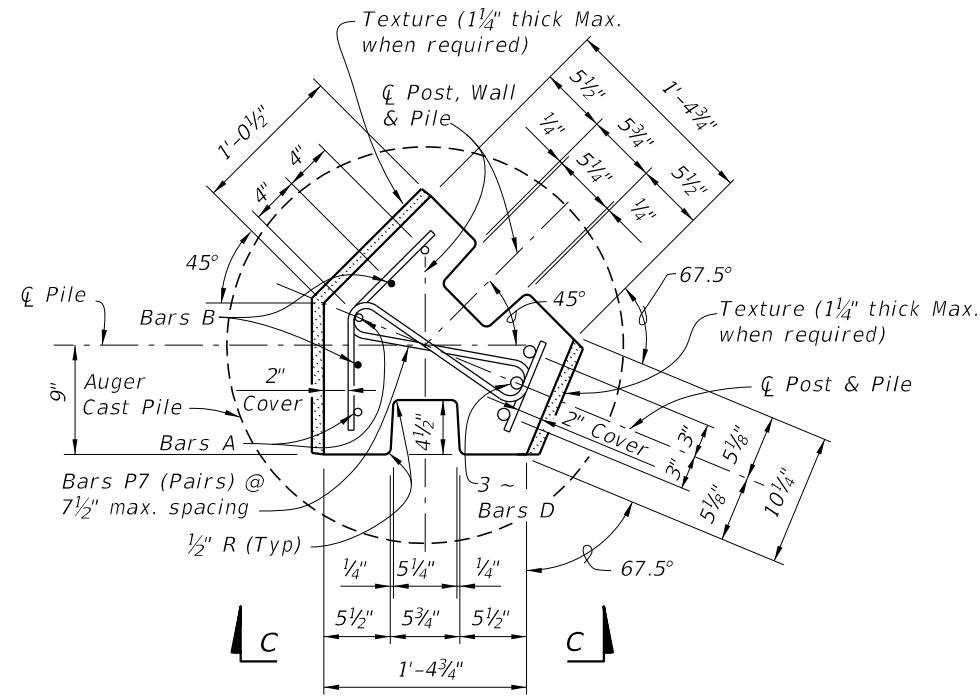

**SECTION A-A  
TYPICAL SECTION ABOVE PILE**

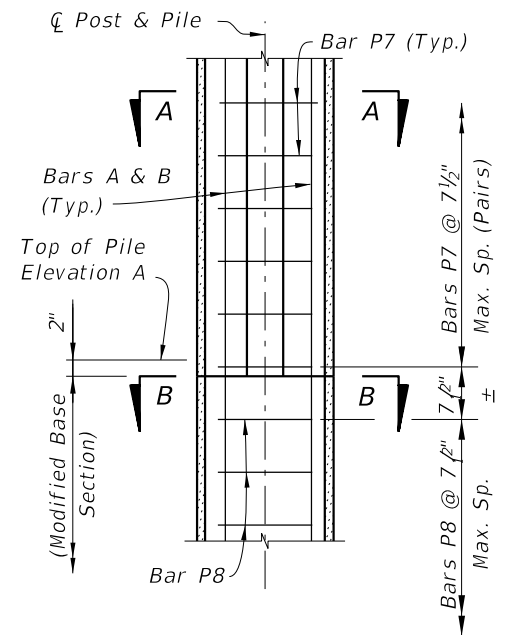

**VIEW C-C (PARTIAL ELEVATION)  
(Only Front Faces Shown for Clarity)**

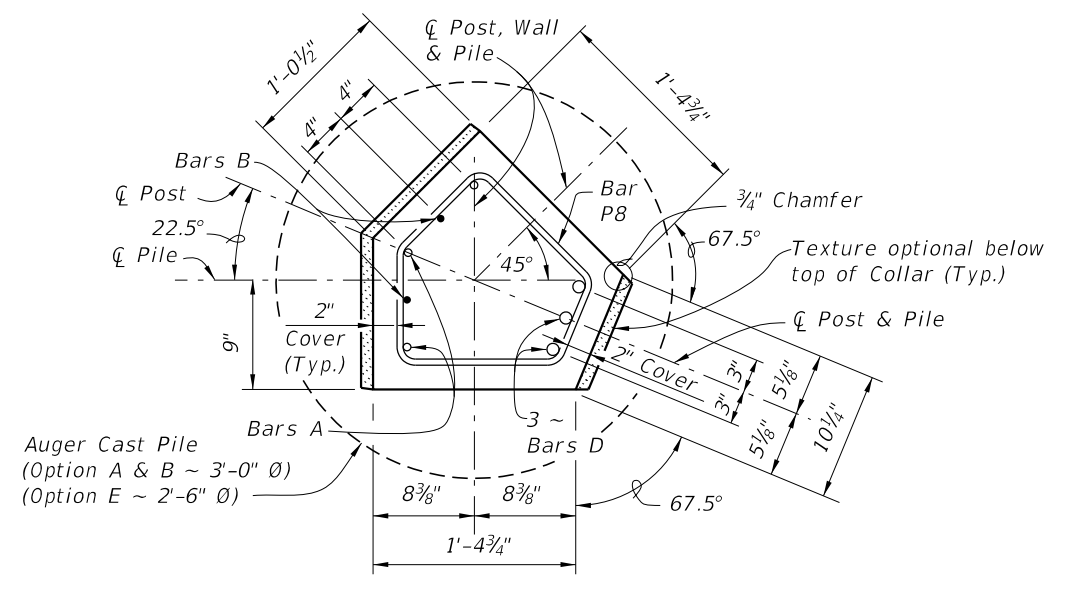

**SECTION B-B  
PRECAST COLLAR SECTION**

**SPECIAL POSTS FOR 45° CORNERS FOR  
PILE/POST CONNECTION OPTIONS A, B & E**

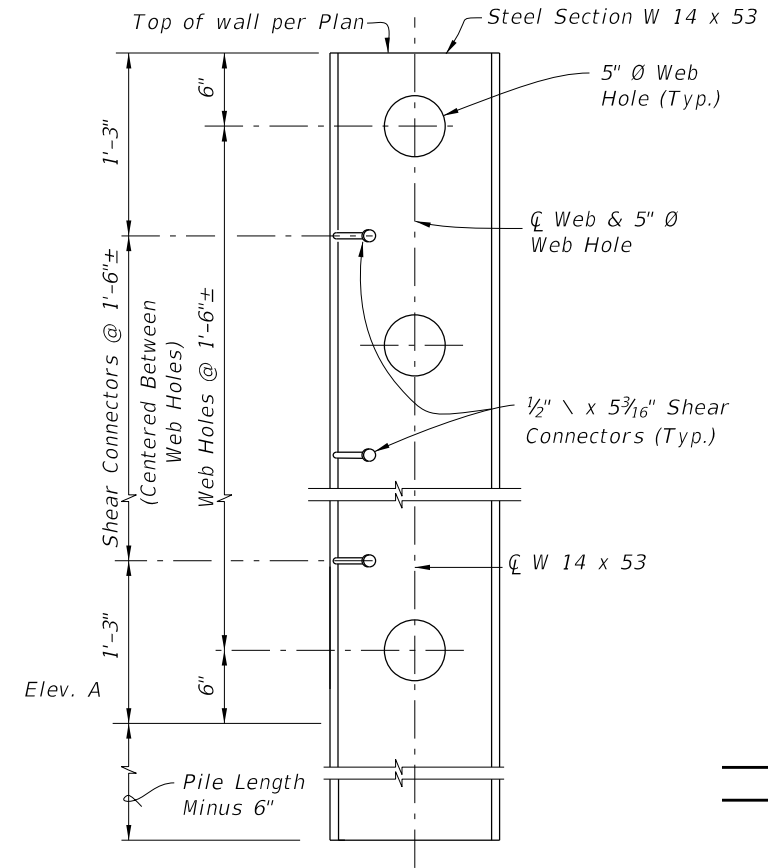

**WEB HOLE AND SHEAR CONNECTOR  
SPACING DETAIL  
(Concrete not shown for clarity)**

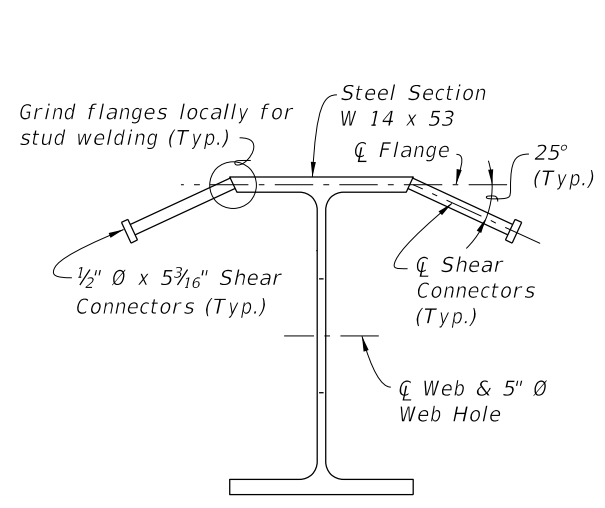

**W 14 x 53 POST DETAIL**

NOTE: The W 14 x 53 Section shall extend into the Auger Cast Pile.

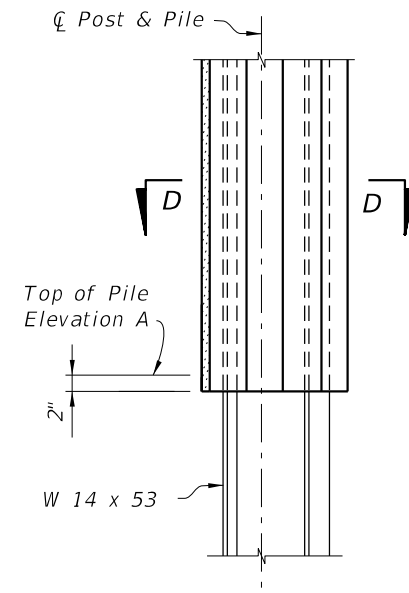

**VIEW E-E (PARTIAL ELEVATION)  
(Only Front Faces Shown for Clarity)**

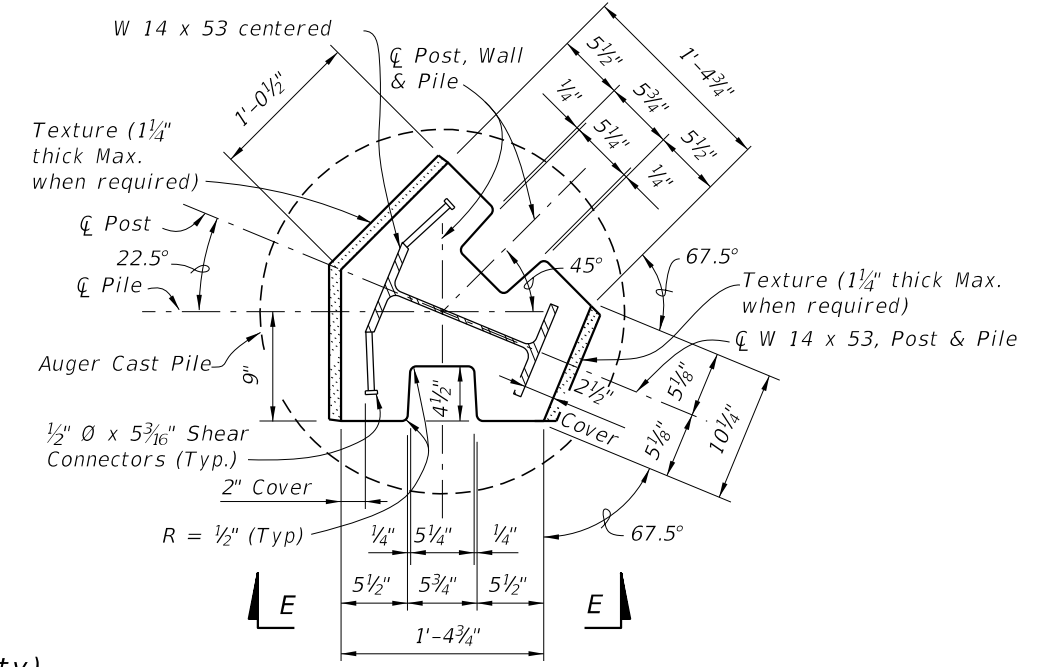

**SECTION D-D  
TYPICAL SECTION ABOVE PILE**

**SPECIAL POSTS FOR 45° CORNERS FOR  
PILE/POST CONNECTION OPTIONS C & D**

- NOTES:
1. For Table of Reinforcing Steel Sizes, see Index No. 5206.
  2. For Pile/Post Connection Options A through E, see Index No. 5205.
  3. For Post & Pile Lengths, see Index No. 5206.
  4. Shear Connectors shall be 5" long after welding.

**SPECIAL 45° CORNER POSTS**

REVISIONS			
DATE	BY	DESCRIPTION	
01/01/10	CMH	New Sheet	
07/01/10	CMH	No Change	

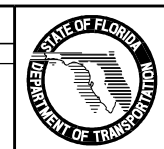

2010 Interim Design Standard  
**PRECAST SOUND BARRIERS  
- FLUSH PANEL OPTION**

Interim Date: 07/01/10  
Sheet No.: 5 of 6  
Index No.: **5202**

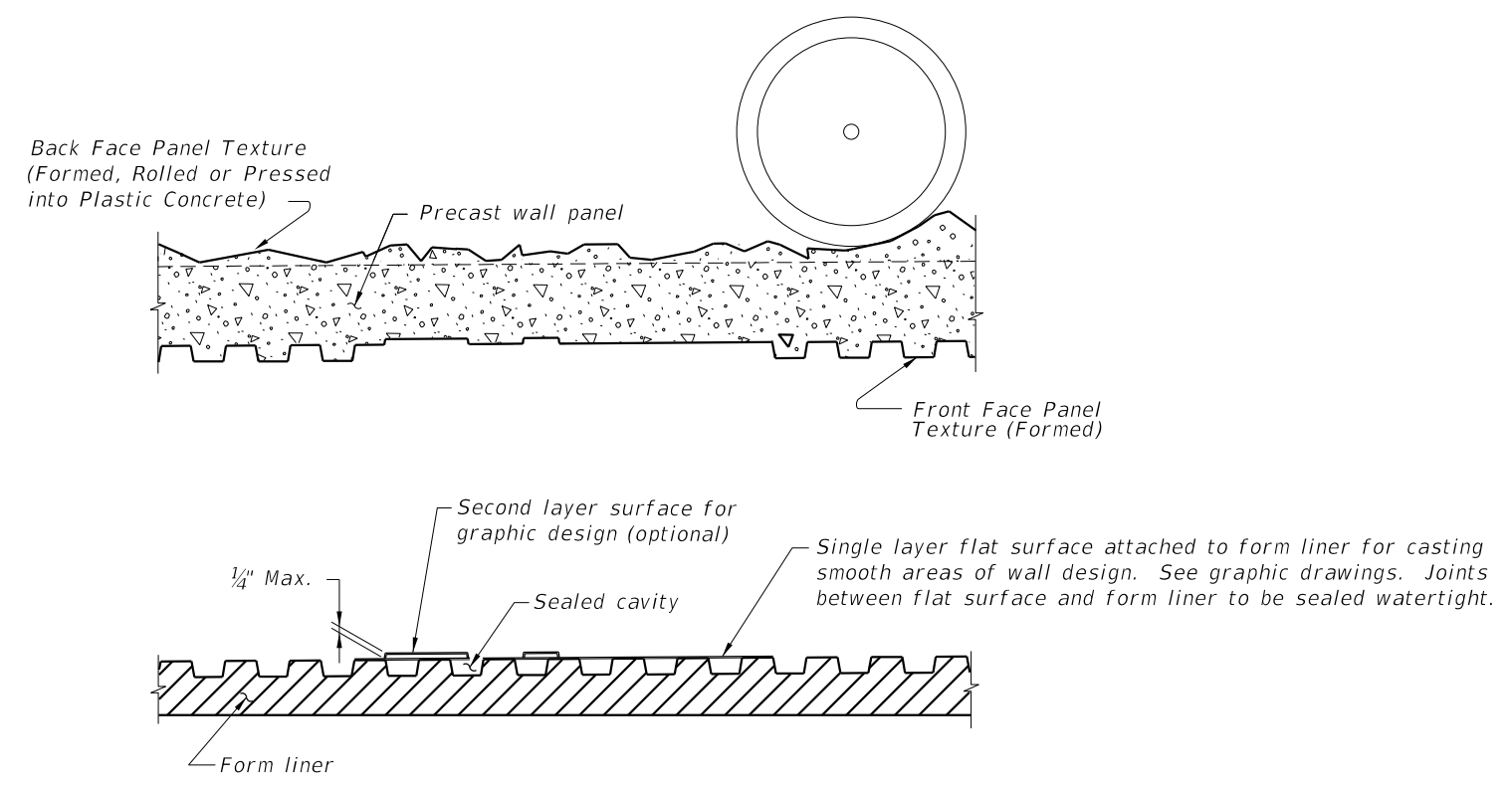
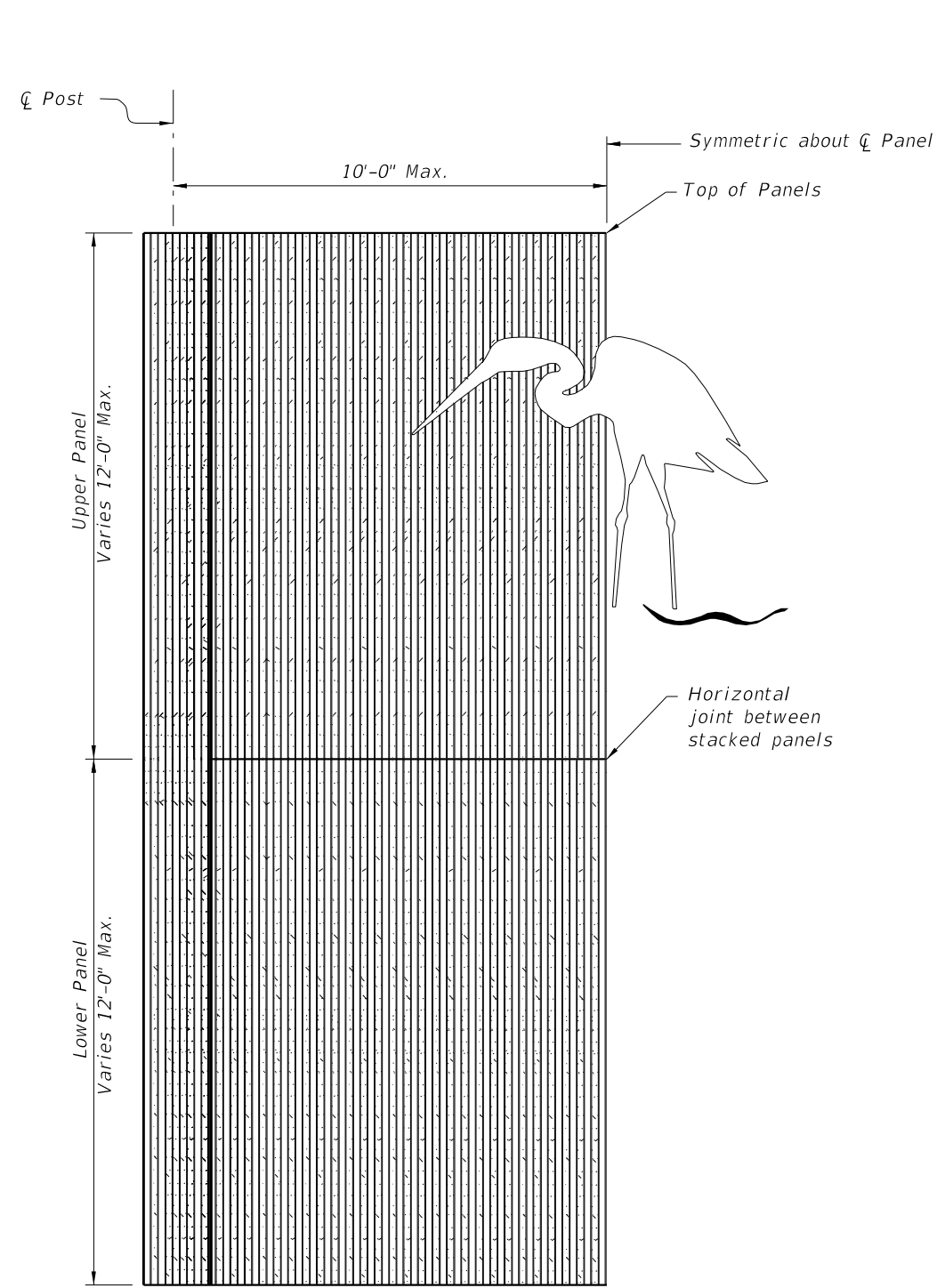

**TYPICAL FORMING DETAIL**  
 (Front Face Panel Texture Type "H" shown)  
 (Back Face Panel Texture Type "D" shown)

- NOTES:
1. Contractor shall submit specific form liner samples for approval by the Engineer.
  2. Textures and graphics shown are for demonstration purposes only. See Wall Control Drawings for project specific texture and graphic requirements.

**HALF ELEVATION**  
 (Pile/Post Connection Options A, B, C and E Shown.)  
 (Front Face Panel Texture Type "H" and Front Face Post Texture Type "H" Shown.)  
 (Graphic Type SE-2 Shown.)

GRAPHICS AND TEXTURE DETAILS

REVISIONS					
DATE	BY	DESCRIPTION	DATE	BY	DESCRIPTION
01/01/10	CMH	Sheet renumbered			
07/01/10	CMH	Added optional texture for non-roadway face of wall.			

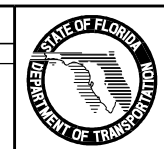

2010 Interim Design Standard  
**PRECAST SOUND BARRIERS**  
**- FLUSH PANEL OPTION**

Interim Date	Sheet No.
07/01/10	6 of 6
Index No.	
<b>5202</b>	