

**GEOSYNTHETIC REINFORCED SOIL SLOPES**

**GENERAL NOTES**

1. All Designs shall meet the requirements shown on this sheet and the contract documents.
2.  $T_a = \frac{T_{ult}}{RF_c RF_d RF_j RF_{LT} CRF}$
3. Intermediate reinforcement shall be rolled out parallel to slope face.

**REVISIONS**

DATE	BY	DESCRIPTION	DATE	BY	DESCRIPTION
01/01/11	LEJ	Added $RF_{LT}$ factor in Note 2; Changed Sheet No. from "1 of 10" to "1 of 12".			

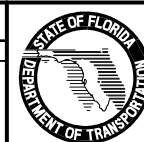

2010 Interim Design Standard

**GEOSYNTHETIC REINFORCED SOILS**

Interim Date	Sheet No.
01/01/11	1 of 12
Index No.	
<b>501</b>	

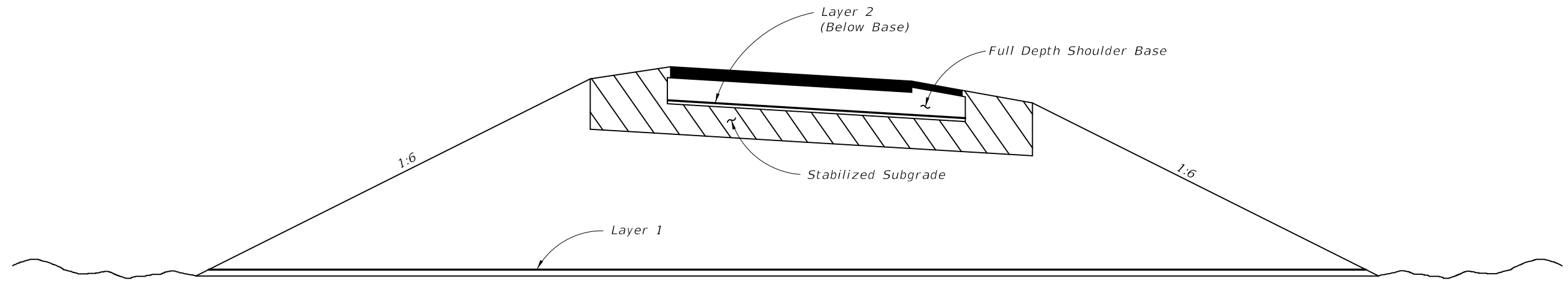

REINFORCED EMBANKMENT

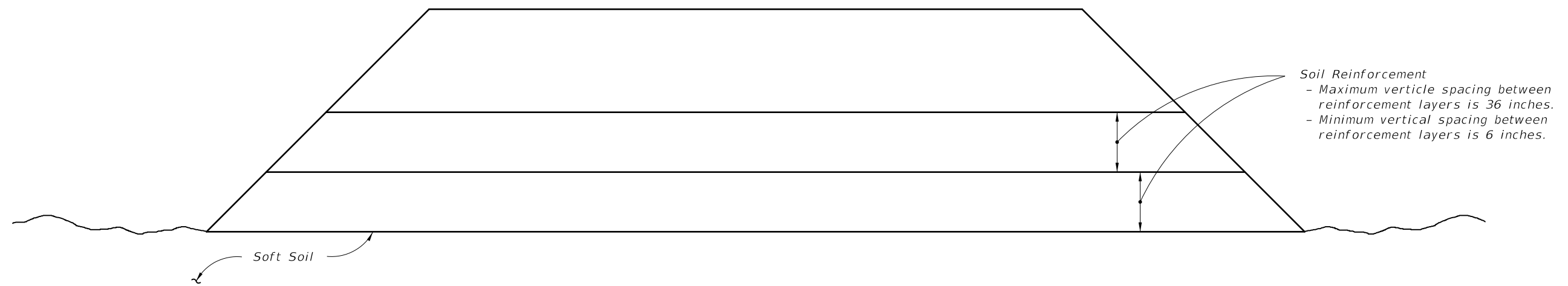

GEOSYNTHETIC REINFORCED FOUNDATIONS CONSTRUCTED ON SOFT SOILS

REVISIONS

DATE	BY	DESCRIPTION	DATE	BY	DESCRIPTION
01/01/11	RH	Changed Sheet No. from "2 of 9" to "2 of 12".			

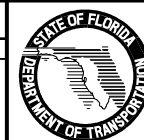

2010 Interim Design Standard

GEOSYNTHETIC REINFORCED SOILS

Interim Date	Sheet No.
01/01/11	2 of 12
Index No.	
501	

TABLE OF WOVEN GEOTEXTILE VALUES

PROPERTY		REQUIRED TEST METHOD	MIRAFI GEOLON HP 370	MIRAFI GEOLON HP 570	MIRAFI GEOLON HP 665	MIRAFI GEOLON HP 770	MIRAFI GEOLON HS 400	MIRAFI GEOLON HS 600	MIRAFI GEOLON HS 800	MIRAFI GEOLON HS 1150	MIRAFI MIRAMESH GR	
Permittivity (0.05 sec <sup>-1</sup> Min.)		ASTM D 4491	0.52	0.40	0.26	0.23	0.1	0.32	0.20	0.32	—	
UV Stability (Min. Retained Strength @ 500 hr.)		ASTM D 4355	70%	70%	70%	70%	50%	50%	50%	50%	90%	
Burst Strength (psi)		ASTM D 6241	800	1,200	1,200	1,200	—	—	—	—	—	
Grab Strength (lb.)		ASTM D 4632	400 x 250	475 x 440	600 x 700	550 x 450	—	—	—	—	—	
A.O.S. (in.)		ASTM D 4751	0.0236	0.0236	0.0167	0.0236	0.0167	0.0335	0.0335	0.0236	0.120 x 0.120	
Tensile Strength (lb./ft.)		ASTM D 4595										
Machine Direction	Ultimate (T <sub>ult</sub> )		3,240	4,800	4,800	7,200	4,800	7,200	9,600	13,800	1,440	
	2% Strain		540	960	—	780	—	—	—	—	—	
	5% Strain		1,356	2,400	1,200	3,600	1,080	2,400	3,600	4,800	—	
Cross Direction	Ultimate		2,700	4,800	6,600	4,800	4,800	3,600	3,600	3,600	1,733	
	2% Strain		540	1,320	—	1,320	—	—	—	—	—	
	5% Strain		1,560	2,604	4,200	3,600	2,400	—	—	—	—	
Strain @ Ultimate Tensile Strength				14%	10%	12%	12%	15%	15%	10%	12%	6%
Secant Modulus (lb./ft.)	2% Strain		27,000	48,000	—	39,000	—	—	—	—	—	—
	5% Strain	27,120	48,000	24,000	72,000	21,600	48,000	72,000	96,000	—		
	10% Strain	24,000	48,000	30,000	66,000	33,600	57,600	96,000	120,000	—		
Seam Breaking Strength (lb./ft.)		ASTM D 4884	1,688	3,000	3,600	3,000	2,400	2,400	2,400	2,400	—	
Puncture Resistance (lb.)		ASTM D 4833	180	195	280	160	—	—	—	—	—	
Tear Strength (lb.)	Machine Direction	ASTM D 4833	170	180	180	250	—	—	—	—	—	
	Cross Direction	ASTM D 4833	110	180	275	300	—	—	—	—	—	
Soil-Geosynthetic Friction		ASTM D 6706	0.8	0.8	0.8	0.8	0.8	0.8	0.8	0.8	0.8	
Creep Resistance-T <sub>creep</sub> (lb./ft.)		ASTM D 5262	—	—	—	—	2,880	4,320	5,760	8,280	471 x 566	
Creep Reduction Factor (T <sub>ult</sub> /T <sub>creep</sub> )			3.5	3.5	3.5	3.5	1.67	1.67	1.67	1.67	3.0	
Installation Damage (RF <sub>c</sub> )	Sand	GRI : GG4 & GT7	1.10	1.10	1.10	1.10	1.15	1.15	1.10	1.10	1.05	
	Limestone		1.25	1.25	1.25	1.25	1.25	1.25	1.20	1.20	1.10	
Durability (RF <sub>d</sub> )	Chemical	ASTM D 5322	1.1	1.1	1.1	1.1	1.1	1.1	1.1	1.1	1.10	
	Biological	ASTM D1987, D3083, G21 & G22	1.0	1.0	1.0	1.0	1.0	1.0	1.0	1.0	1.0	
Joint Strength (RF <sub>j</sub> )	Mechanical	ASTM D 4595, GRI : GG4 & GT7	—	—	—	—	—	—	—	—	—	
	Overlap *	ASTM D 6706	1.0	1.0	1.0	1.0	1.0	1.0	1.0	1.0	1.0	
Approved Application Usage			3, 4	3, 4	3, 4	3, 4	3, 4	3, 4	3, 4	3, 4	1,4	

Approved Application Usage: 1 = Steepened Slopes  
 2 = Reinforcement of Foundations over Soft Soils  
 3 = Both Steepened Slopes & Reinforcement of Foundations over Soft Soils  
 4 = Reinforced Embankment  
 \* Minimum 3' Overlap 5 = Construction Expedient

APPROVED GEOSYNTHETIC PRODUCTS  
 (WOVEN GEOTEXTILE)  
 APPLICATION AND PROPERTIES

REVISIONS				2010 Interim Design Standard				Interim Date	Sheet No.
DATE	BY	DESCRIPTION	DATE	BY	DESCRIPTION			01/01/11	3 of 12
07/01/08	LJ	Changed Required Test Method for Burst Strength, Soil-Geosynthetic Friction, Creep Reduction Factor, and Overlap Joint Strength.							
01/01/11	RH	Changed Sheet No. from "3 of 10" to "3 of 12".							

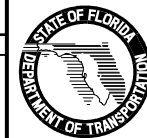

TABLE OF WOVEN GEOTEXTILE VALUES

PROPERTY		REQUIRED TEST METHOD	MIRAFI BXG11	MIRAFI BXG12	MIRAFI GEOLON HS 2400	MIRAFI GEOLON HS 3000	COMTRAC 70.70	GEOTEX 315ST	GEOTEX 2x2HF	GEOTEX 3x3HF	GEOTEX 4x4	GEOTEX 4x4HF	GEOTEX 4X6	
Permittivity (0.05 sec <sup>-1</sup> Min.)		ASTM D 4491	—	—	0.02	0.02	0.20	0.04	0.65	0.18	0.15	0.40	0.26	
UV Stability (Min. Retained Strength @ 500 hr.)		ASTM D 4355	70%	70%	70%	70%	70%	70%	70%	70%	70%	70%	70%	
Burst Strength (psi)		ASTM D 6241	—	—	—	—	—	1,000	1,100	1,000	1,500	1,200	1,500	
Grab Strength (lb.)		ASTM D 4632	—	—	—	—	—	315	315	450/350	600/500	475/440	600/700	
A.O.S. (in.)		ASTM D 4751	1.0 x 1.0	1.0 x 1.0	0.0118	0.0118	0.0181	0.0167	0.0167	0.0236	0.0236	0.533	0.312	
Tensile Strength (lb./ft.)		ASTM D 4595												
Machine Direction	Ultimate (T <sub>ult</sub> )		2,000	2,000	28,800	36,000	4,800	2,100	2,400	3,600	4,800	4,800	4,800	
	2% Strain		500	500	—	—	—	156	276	400	456	960	700	
	5% Strain		920	920	14,400	18,000	2,196	564	744	1,392	1,452	2,400	1,200	
Cross Direction	Ultimate		2,000	4,000	3,600	3,600	3,600	2,100	2,400	3,600	4,800	4,800	6,600	
	2% Strain		500	750	—	—	—	576	660	400	1,380	1,320	1,000	
	5% Strain		920	1,350	—	—	—	1,104	1,404	1,740	2,604	2,400	2,640	
Strain @ Ultimate Tensile Strength				12%	12%	10%	10%	9%	15%	10%	10%	10%	8%	8%
Secant Modulus @ (lb./ft.)	2% Strain		ASTM D 4595	25,000	25,000	—	—	—	7,800	13,800	27,000	22,800	48,000	48,000
	5% Strain	18,400		18,400	288,000	360,000	24,400	11,280	14,880	27,000	29,040	48,000	48,000	
	10% Strain	—		—	288,000	360,000	24,400	10,440	12,480	24,000	31,200	48,000	48,000	
Seam Breaking Strength (lb./ft.)		ASTM D 4884			3,600	3,600	2,400	—	—	—	—	—	—	
Puncture Resistance (lb.)		ASTM D 4833	—	—	—	—	—	120	120	180	170	190	280	
Tear Strength (lb.)	Machine Direction	ASTM D 4833	—	—	—	—	—	120	120	180	250	180	180	
	Cross Direction	ASTM D 4833	—	—	—	—	—	120	120	110	250	180	250	
Soil-Geosynthetic Friction		ASTM D 6706	0.8	0.8	0.8	0.8	0.9	0.65	0.65	0.65	0.65	0.65	0.65	
Creep Resistance-T <sub>creep</sub> (lb./ft.)		ASTM D 5262	—	—	17,280	21,600	—	600	—	—	—	—	—	
Creep Reduction Factor (T <sub>ult</sub> /T <sub>creep</sub> )			1.6	1.6	1.67	1.67	1.67	3.5	5.0	5.0	5.0	5.0	5.0	
Installation Damage (RF <sub>c</sub> )	Sand	GRI : GG4 & GT7	1.05	1.05	1.1	1.1	1.2	1.4	1.4	1.4	1.4	1.4	1.4	
	Limestone		1.10	1.10	1.20	1.20	1.5	1.4	1.4	1.5	1.4	1.4	1.4	
Durability (RF <sub>d</sub> )	Chemical	ASTM D 5322	1.1	1.1	1.1	1.1	1.1	1.1	1.1	1.1	1.1	1.1	1.1	
	Biological	ASTM D1987, D3083, G21 & G22	1.0	1.0	1.0	1.0	1.0	1.1	1.1	1.1	1.1	1.1	1.1	
Joint Strength (RF <sub>j</sub> )	Mechanical	ASTM D 4595, GRI : GG4 & GT7	—	—	—	—	—	—	—	—	—	—	—	
	Overlap *	ASTM D 6706	1.0	1.0	1.0	1.0	1.0	1.2	1.2	1.0	1.2	1.0	1.2	
Approved Application Usage			3, 4	3, 4	3, 4	3, 4	3	2	2	2	2	2	2	

Approved Application Usage: 1 = Steepened Slopes  
 2 = Reinforcement of Foundations over Soft Soils  
 3 = Both Steepened Slopes & Reinforcement of Foundations over Soft Soils  
 4 = Reinforced Embankment  
 5 = Construction Expedient  
 \* Minimum 3' Overlap

APPROVED GEOSYNTHETIC PRODUCTS  
 (WOVEN GEOTEXTILE)  
 APPLICATION AND PROPERTIES

REVISIONS					
DATE	BY	DESCRIPTION	DATE	BY	DESCRIPTION
07/01/08	LJ	Changed Required Test Method for Burst Strength, Soil-Geosynthetic Friction, Creep Reduction Factor, and Overlap Joint Strength. Changed Properties for Comtrac 70.70.	01/01/09	LJ	Deleted AMOCO 2006, 2016 and 2040.
			01/01/11	RH	Added GEOTEX 315ST, 2x2HF, 3x3HF, 4x4, 4x4HF and 4x6. Changed Sheet No. from "4 of 10" to "4 of 12".

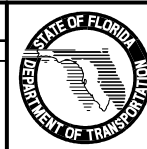

2010 Interim Design Standard

GEOSYNTHETIC REINFORCED SOILS

Interim Date	Sheet No.
01/01/11	4 of 12
Index No.	
501	

TABLE OF WOVEN GEOTEXTILE VALUES

PROPERTY		REQUIRED TEST METHOD	TENCATE HP270	TENCATE HP370	TENCATE HP570	TENCATE HP665	TENCATE HP770	TENCATE MMESH/GR	TENCATE MMESH/SG	TENCATE HS400	TENCATE HS600	TENCATE HS800	TENCATE HS1150	
Permittivity (0.05 sec <sup>-1</sup> Min.)		ASTM D 4491	0.5	0.52	0.4	0.26	0.23	--	--	0.1	0.32	0.2	0.32	
UV Stability (Min. Retained Strength @ 500 hr.)		ASTM D 4355	80%	80%	80%	70%	80%	90%	90%	50%	50%	50%	50%	
Burst Strength (psi)		ASTM D 6241	--	--	--	--	--	--	--	--	--	--	--	
Grab Strength (lb.)		ASTM D 4632	290/255	400/250	475/440	600/700	550/450	--	--	--	--	--	--	
A.O.S. (in.)		ASTM D 4751	0.0236	0.0236	0.0236	0.0167	0.0236	--	--	0.0169	0.0335	0.0335	0.0236	
Tensile Strength (lb./ft.)		ASTM D 4595												
Machine Direction	Ultimate (T <sub>ult</sub> )		2640	3600	4800	4800	7200	1440	1440	4800	7200	9600	13800	
	2% Strain		480	540	960	300	1140	--	--	--	--	--	--	
	5% Strain		1212	1500	2400	1200	3600	--	--	1080	2400	3600	6000	
Cross Direction	Ultimate		2460	2700	4800	6600	5760	1733	1733	4800	3600	3600	3600	
	2% Strain		588	540	1320	1740	1560	--	--	--	--	--	--	
	5% Strain		1356	1560	2700	4200	3600	--	--	2400	1800	1200	--	
Strain @ Ultimate Tensile Strength				10%	10%	10%	10%	10%	6%	6%	10%	10%	10%	10%
Secant Modulus @ (lb./ft.)	2% Strain		ASTM D 4595	24000	27000	48000	48000	57000	--	--	--	--	--	--
	5% Strain	24240		30000	48000	48000	72000	--	--	21600	48000	72000	120000	
	10% Strain	23400		--	--	50400	66000	--	--	33600	--	90000	--	
Seam Breaking Strength (lb./ft.)		ASTM D 4884	1260	1260	3000	3600	3000	--	--	2400	2400	2400	2400	
Puncture Resistance (lb.)		ASTM D 4833	--	180	--	1650	--	--	--	--	--	--	--	
Tear Strength (lb.)	Machine Direction	ASTM D 4833	120	170	180	180	250	--	--	--	--	--	--	
	Cross Direction	ASTM D 4833	140	125	180	275	300	--	--	--	--	--	--	
Soil-Geosynthetic Friction		ASTM D 6706	0.8	0.8	900	0.8	0.8	0.8	0.8	0.8	0.8	0.8	0.8	
Creep Resistance-T <sub>creep</sub> (lb./ft.)		ASTM D 5262	660	900	900	1650	1800	471	471	2880	4320	5760	8280	
Creep Reduction Factor (T <sub>ult</sub> /T <sub>creep</sub> )			4	4	4	4	4	3.7	3.7	1.67	1.67	1.67	1.67	
Installation Damage (RF <sub>c</sub> )	Sand	GRI : GG4 & GT7	1.1	1.1	1.1	1.1	1.1	1.05	1.05	1.15	1.15	1.15	1.15	
	Limestone		1.5	1.5	1.5	1.5	1.5	1.1	1.1	1.25	1.25	1.25	1.25	
Durability (RF <sub>d</sub> )	Chemical	ASTM D 5322	1.1	1.1	1.1	1.1	1.1	--	1.1	1.1	1.1	1.1	1.1	
	Biological	ASTM D1987, D3083, G21 & G22	1.0	1.0	1.0	1.0	1.0	--	1.0	1.0	1.0	1.0	1.0	
Joint Strength (RF <sub>j</sub> )	Mechanical	ASTM D 4595, GRI : GG4 & GT7	--	--	--	--	--	--	--	--	--	--	--	
	Overlap *	ASTM D 6706	1.0	1.0	1.0	1.0	1.0	--	--	--	--	--	--	
Approved Application Usage			3, 4, 5	3, 4, 5	3, 4, 5	3, 4, 5	3, 4, 5	1, 4, 5	1, 4, 5	3, 4, 5	3, 4, 5	3, 4, 5	3, 4, 5	

Approved Application Usage: 1 = Steepened Slopes  
 2 = Reinforcement of Foundations over Soft Soils  
 3 = Both Steepened Slopes & Reinforcement of Foundations over Soft Soils  
 4 = Reinforced Embankment  
 5 = Construction Expedient  
 \* Minimum 3' Overlap

APPROVED GEOSYNTHETIC PRODUCTS  
 (WOVEN GEOTEXTILE)  
 APPLICATION AND PROPERTIES

REVISIONS				2010 Interim Design Standard				Interim Date	Sheet No.
DATE	BY	DESCRIPTION	DATE	BY	DESCRIPTION			01/01/11	5 of 12
01/01/11	RH	New Sheet.							
								Index No.	
								501	
						<b>GEOSYNTHETIC REINFORCED SOILS</b>			

TABLE OF WOVEN GEOGRID VALUES

PROPERTY		REQUIRED TEST METHOD	MIRAFI MG 2XT	MIRAFI MG 3XT	MIRAFI MG 5XT (Matrex 30)	MIRAFI MG 7XT	MIRAFI MG 8XT	MIRAFI MG 10XT (Matrex 60)	MIRAFI MG 18XT (Matrex 90)	MIRAFI MG 20XT (Matrex 120)	MIRAFI MG 22XT (Matrex 180)	MIRAFI MG 24XT (Matrex 240)	
UV Stability (Min. Retained Strength @ 500 hr.)		ASTM D 4355	70%	70%	70%	70%	70%	70%	70%	70%	70%	70%	
Tensile Strength (lb./ft.)		ASTM D 6637											
Machine Direction	Ultimate ( $T_{Ult}$ )		2,000	3,150	4,300	5,700	7,000	9,500	9,360	12,420	17,760	25,380	
	2% Strain		—	—	—	—	—	—	—	—	—	—	
	5% Strain		1,000	1,056	1,740	2,160	2,520	3,120	3,250	5,340	6,700	7,000	
Cross Direction	Ultimate		2,000	—	—	—	—	—	—	—	—	—	—
	2% Strain		—	—	—	—	—	—	—	—	—	—	—
	5% Strain	—	—	—	—	—	—	—	—	—	—	—	
Strain @ Ultimate Tensile Strength		ASTM D 6637	10%	10%	10%	10%	10%	10%	10%	10%	10%	10%	
Secant Modulus @ (lb./ft.)	2% Strain		—	—	—	—	—	—	—	—	—	—	
	5% Strain		20,000	21,120	34,800	43,200	50,400	62,400	65,000	106,800	134,000	140,000	
	10% Strain		—	—	—	—	—	—	—	—	—	—	
Junction Strength (lb./ft.)		GRI : GG2	—	—	—	—	—	—	—	—	—	—	
Soil-Geosynthetic Friction		ASTM D 6706	0.8	0.8	0.8	0.8	0.8	0.8	0.8	0.8	0.8	0.8	
Creep Resistance- $T_{creep}$ (lb./ft.)		ASTM D 5262	1,250	1,969	2,688	3,563	4,375	5,938	5,850	7,221	10,326	14,756	
Creep Reduction Factor ( $T_{It} / T_{creep}$ )			1.6	1.6	1.6	1.6	1.6	1.6	1.6	1.72	1.72	1.72	
Installation Damage (RF <sub>C</sub> )	Sand	GRI : GG4 & GT7	1.05	1.05	1.05	1.05	1.05	1.05	1.05	1.05	1.05	1.05	
	Limestone		1.5	1.25	1.25	1.25	1.25	1.25	1.25	1.25	1.25	1.25	
Durability (RF <sub>D</sub> )	Chemical	ASTM D 5322	1.1	1.1	1.1	1.1	1.1	1.1	1.1	1.1	1.1	1.1	
	Biological	ASTM D1987, D3083, G21 & G22	1.0	1.0	1.0	1.0	1.0	1.0	1.0	1.0	1.0	1.0	
Joint Strength (RF <sub>J</sub> )	Mechanical	ASTM D 6637, GRI : GG4 & GT7	—	—	—	—	—	—	—	—	—	—	
	Overlap *	ASTM D 6706	1.2	1.2	1.2	1.2	1.2	1.2	1.2	1.2	1.2	1.2	
Approved Application Usage			3	3	3	3	3	3	3	3	3	3	

Approved Application Usage:  
 1 = Steepened Slopes  
 2 = Reinforcement of Foundations over Soft Soils  
 3 = Both Steepened Slopes & Reinforcement of Foundations over Soft Soils  
 4 = Reinforced Embankment  
 5 = Construction Expedient  
 \* Minimum 3' Overlap

APPROVED GEOSYNTHETIC PRODUCTS  
 (WOVEN GEOGRID)  
 APPLICATION AND PROPERTIES

REVISIONS				2010 Interim Design Standard				Interim Date	Sheet No.
DATE	BY	DESCRIPTION	DATE	BY	DESCRIPTION			01/01/11	6 of 12
01/01/10	LJ	Correct "MARAFL" to "MIRAFI".							
01/01/11	RH	Changed Sheet No. from '5 of 10' to '6 of 12'.							
								<b>GEOSYNTHETIC REINFORCED SOILS</b> Index No. <b>501</b>	

TABLE OF WOVEN GEOGRID VALUES									
PROPERTY		REQUIRED TEST METHOD	RAUGRID 3/3	RAUGRID 4/2	RAUGRID 6/3	RAUGRID 8/3	RAUGRID 10/3	FORNIT 20	FORNIT 30
UV Stability (Min. Retained Strength @ 500 hr.)		ASTM D 4355	95%	95%	95%	95%	95%	92%	92%
Tensile Strength (lb./ft.)		ASTM D 6637							
Machine Direction	Ultimate ( $T_{ult}$ )		2,233	2,843	4,350	5,288	6,590	1,159	1,890
	2% Strain		—	—	—	—	—	360	600
	5% Strain		712	767	1,144	1,165	1,582	774	1,390
Cross Direction	Ultimate		2,213	1,459	1,959	2,089	2,192	1,641	2,466
	2% Strain		—	—	—	—	—	543	778
	5% Strain	541	356	452	507	521	1,111	1,719	
Strain @ Ultimate Tensile Strength		ASTM D 6637	10.8%	11.8%	13.1%	12.2%	11.5%	6%	6%
Secant Modulus (lb./ft.)	2% Strain		—	—	—	—	—	18,000	30,000
	5% Strain		—	—	—	—	—	15,480	27,800
	10% Strain		—	—	—	—	—	—	—
Junction Strength (lb./ft.)		GRI : GG2	N/A	100%	100%	100%	100%	30	32.2
Soil-Geosynthetic Friction		ASTM D 6706	0.8	0.8	0.8	0.8	0.8	0.9	0.9
Creep Resistance- $T_{creep}$ (lb./ft.)		ASTM D 5262	1,466	1,870	2,862	3,479	4,335	355	588
Creep Reduction Factor ( $T_{ult}/T_{creep}$ )			1.52	1.52	1.52	1.52	1.52	3.5	3.5
Installation Damage ( $RF_C$ )	Sand	GRI : GG4 & GT7	1.10	1.10	1.10	1.10	1.10	1.10	1.10
	Limestone		1.17	1.17	1.17	1.17	1.17	1.10	1.10
Durability ( $RF_D$ )	Chemical	ASTM D 5322	1.15	1.15	1.15	1.15	1.15	1.10	1.10
	Biological	ASTM D1987, D3083, G21 & G22	1.15	1.15	1.15	1.15	1.15	1.0	1.0
Joint Strength ( $RF_J$ )	Mechanical	ASTM D 6637, GRI : GG4 & GT7	—	—	—	—	—	—	—
	Overlap *	ASTM D 6706	—	—	—	—	—	1.0	1.1
Approved Application Usage			2, 5	2, 5	2, 5	2, 5	2, 5	2, 4, 5	2, 4, 5

Approved Application Usage:  
 1 = Steepened Slopes  
 2 = Reinforcement of Foundations over Soft Soils  
 3 = Both Steepened Slopes & Reinforcement of Foundations over Soft Soils  
 4 = Reinforced Embankment  
 5 = Construction Expedient  
 \* Minimum 3' Overlap

APPROVED GEOSYNTHETIC PRODUCTS  
 (WOVEN GEOGRID)  
 APPLICATION AND PROPERTIES

REVISIONS

DATE	BY	DESCRIPTION
01/01/10	LJ	Added FORNIT 30. Added Creep Resistance, Creep Reduction and Application Usage "4" to FORNIT 20.
01/01/11	RH	Changed Sheet No. from '7 of 10' to '7 of 12'.

DATE	BY	DESCRIPTION

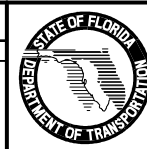

2010 Interim Design Standard

GEOSYNTHETIC REINFORCED SOILS

Interim Date	Sheet No.
01/01/11	7 of 12
Index No.	
501	

TABLE OF WOVEN GEOGRID VALUES

PROPERTY		REQUIRED TEST METHOD	STRATAGRID MICROGRID	STRATAGRID SG 150	STRATAGRID SG 200	STRATAGRID SG 350	STRATAGRID SG 500	STRATAGRID SG 550	STRATAGRID SG 600	STRATAGRID SG 700
UV Stability (Min. Retained Strength @ 500 hr.)		ASTM D 4355	70%	70%	70%	70%	70%	70%	70%	70%
Tensile Strength (lb./ft.)		ASTM D 6637	—	—	—	—	—	—	—	—
Machine Direction	Ultimate ( $T_{ult}$ )		2,000	1,875	3,400	4,800	6,300	7,800	8,700	11,750
	2% Strain		—	—	—	—	—	—	—	—
	5% Strain		600	450	700	750	1,150	1,200	1,400	1,700
Cross Direction	Ultimate		2,000	1,875	—	—	—	—	—	—
	2% Strain		—	—	—	—	—	—	—	—
	5% Strain	450	—	—	—	—	—	—	—	
Strain @ Ultimate Tensile Strength		ASTM D 6637	15.0%	15.0%	15.0%	15.0%	15.0%	15.0%	18.0%	18.0%
Secant Modulus @ (lb./ft.)	2% Strain		—	—	—	—	—	—	—	—
	5% Strain		12,000	9,000	14,000	15,000	23,000	24,000	24,000	34,000
	10% Strain		—	—	—	—	—	—	—	—
Junction Strength (lb./ft.)		GRI : GG2	—	—	—	—	—	—	—	—
Soil-Geosynthetic Friction		ASTM D 6706	0.8	0.8	0.8	0.8	0.8	0.8	0.8	0.8
Creep Resistance- $T_{creep}$ (lb./ft.)		ASTM D 5262	1,149	1,210	2,194	3,097	4,065	5,032	5,613	7,581
Creep Reduction Factor ( $T_{ult}/T_{creep}$ )			1.74	1.55	1.55	1.55	1.55	1.55	1.55	1.55
Installation Damage (RF <sub>c</sub> )	Sand	GRI : GG4 & GT7	1.20	1.10	1.10	1.05	1.05	1.05	1.05	1.05
	Limestone		1.90	1.20	1.20	1.20	1.15	1.15	1.15	1.15
Durability (RF <sub>d</sub> )	Chemical	ASTM D 5322	1.10	1.10	1.10	1.10	1.10	1.10	1.10	1.10
	Biological	ASTM D1987, D3083, G21 & G22	1.10	1.10	1.10	1.10	1.10	1.10	1.10	1.10
Joint Strength (RF <sub>j</sub> )	Mechanical	ASTM D 6637, GRI : GG4 & GT7	—	—	—	—	—	—	—	—
	Overlap *	ASTM D 6706	1.25	1.25	1.25	1.25	1.25	1.25	1.25	1.25
Approved Application Usage			3, 4, 5	3, 4, 5	3, 4	3, 4	3, 4	3, 4	3, 4	3, 4

Approved Application Usage:

- 1 = Steepened Slopes
- 2 = Reinforcement of Foundations over Soft Soils
- 3 = Both Steepened Slopes & Reinforcement of Foundations over Soft Soils
- 4 = Reinforced Embankment
- 5 = Construction Expedient
- \* Minimum 3' Overlap

APPROVED GEOSYNTHETIC PRODUCTS  
(WOVEN GEOGRID)  
APPLICATION AND PROPERTIES

REVISIONS

DATE	BY	DESCRIPTION	DATE	BY	DESCRIPTION
01/01/10	LJ	New Sheet Added			
01/01/11	RH	Changed Sheet No. from '8 of 10' to '8 of 12'.			

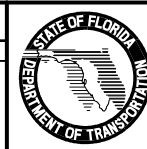

2010 Interim Design Standard

GEOSYNTHETIC REINFORCED SOILS

Interim Date	Sheet No.
01/01/11	8 of 12
Index No.	
501	



TABLE OF WOVEN GEOGRID VALUES

PROPERTY		REQUIRED TEST METHOD	SYNTEEN SF 11	SYNTEEN SF 12	SYNTEEN SF 20	SYNTEEN SF 35	SYNTEEN SF 40	SYNTEEN SF 50	SYNTEEN SF 55	SYNTEEN SF 80	SYNTEEN SF 110
UV Stability (Min. Retained Strength @ 500 hr.)		ASTM D 4355	70%	70%	70%	70%	70%	70%	70%	70%	70%
Tensile Strength (lb./ft.)		ASTM D 6637									
Machine Direction	Ultimate ( $T_{ult}$ )		2,388	2,388	1,672	2,627	3,050	3,731	3,774	5,583	7,462
	2% Strain		526	526	370	462	488	791	736	1,016	1,186
	5% Strain		990	1,042	670	725	970	922	1,159	1,273	1,684
Cross Direction	Ultimate		3,870	5,268	1,630	2,556	3,050	3,933	2,499	2,206	2,179
	2% Strain		578	797	370	399	430	630	604	882	1,274
	5% Strain	792	1,129	670	583	765	815	796	1,563	1,581	
Strain @ Ultimate Tensile Strength		ASTM D 6637	12.6%	13.0%	9.4%	14.1%	9.9%	14.2%	11.5%	13.9%	18.8%
Secant Modulus @ (lb./ft.)	2% Strain		26,300	26,300	18,494	23,114	24,408	39,551	36,799	50,807	59,298
	5% Strain		15,840	20,840	13,397	14,499	19,404	18,432	23,174	25,459	33,712
	10% Strain		—	—	15,206	15,234	22,089	18,432	27,137	37,910	27,380
Junction Strength (lb./ft.)		GRI : GG2	354	320	—	—	—	—	—	—	—
Soil-Geosynthetic Friction		ASTM D 6706	1.0	1.0	0.8	0.8	0.8	0.8	0.8	0.8	0.8
Creep Resistance- $T_{creep}$ (lb./ft.)		ASTM D 5262	—	—	1,005	1,523	1,525	2,201	2,265	3,182	4,029
Creep Reduction Factor ( $T_{ult}/T_{creep}$ )			—	—	1.66	1.73	2.00	1.70	1.67	1.75	2.02
Installation Damage (RF <sub>c</sub> )	Sand	GRI : GG4 & GT7	1.18	1.06	1.05	1.15	1.15	1.08	1.08	1.08	1.08
	Limestone		1.31	1.20	1.75	1.70	1.60	1.55	1.55	1.55	1.35
Durability (RF <sub>d</sub> )	Chemical	ASTM D 5322	1.10	1.10	1.10	1.10	1.10	1.10	1.10	1.10	1.10
	Biological	ASTM D1987, D3083, G21 & G22	1.10	1.10	1.10	1.10	1.10	1.10	1.10	1.10	1.10
Joint Strength (RF <sub>j</sub> )	Mechanical	ASTM D 6637, GRI : GG4 & GT7	—	—	—	—	—	—	—	—	—
	Overlap *	ASTM D 6706	1.10	1.10	1.10	1.10	1.10	1.10	1.10	1.10	1.10
Approved Application Usage			2, 5	2, 5	3	3	3	3	3	3	3

Approved Application Usage:

- 1 = Steepened Slopes
- 2 = Reinforcement of Foundations over Soft Soils
- 3 = Both Steepened Slopes & Reinforcement of Foundations over Soft Soils
- 4 = Reinforced Embankment
- 5 = Construction Expedient
- \* Minimum 3' Overlap

APPROVED GEOSYNTHETIC PRODUCTS  
(WOVEN GEOGRID)  
APPLICATION AND PROPERTIES

REVISIONS

DATE	BY	DESCRIPTION	DATE	BY	DESCRIPTION
01/01/10	LJ	Added Application Usage 2 for SYNTEEN SF 11 & SF 12.			
01/01/11	RH	Changed Sheet No. from '6 of 10' to '9 of 12'.			

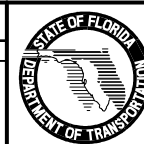

2010 Interim Design Standard

GEOSYNTHETIC REINFORCED SOILS

Interim Date	Sheet No.
01/01/11	9 of 12
Index No.	
501	

TABLE OF WOVEN GEOGRID VALUES

PROPERTY		REQUIRED TEST METHOD	TENCATE BXG11	TENCATE BXG12	TENCATE 2XT	TENCATE 3XT	TENCATE 5XT	TENCATE 7XT	TENCATE 8XT	TENCATE 10XT	TENCATE 20XT	TENCATE 22XT	TENCATE 24XT
UV Stability (Min. Retained Strength @ 500 hr.)		ASTM D 4355	70%	70%	70%	70%	70%	70%	70%	70%	70%	70%	70%
Tensile Strength (lb./ft.)		ASTM D 6637											
Machine Direction	Ultimate ( $T_{Ult}$ )		2500	2500	2000	3500	4700	5900	7400	9500	13705	17760	27415
	2% Strain		625	625	--	--	--	--	--	--	--	--	--
	5% Strain		1000	1000	950	1056	1740	2160	2520	3120	5340	6700	7000
Cross Direction	Ultimate		2500	4500	2000	--	--	--	--	--	--	--	--
	2% Strain		625	840	--	--	--	--	--	--	--	--	--
	5% Strain	1000	1350	--	--	--	--	--	--	--	--	--	
Strain @ Ultimate Tensile Strength		ASTM D 6637	12%	12%	10%	10%	10%	10%	10%	10%	10%	10%	10%
Secant Modulus (lb./ft.)	2% Strain		31250	31250	--	--	--	--	--	--	--	--	--
	5% Strain		20000	20000	19000	21120	34800	43200	50400	62400	106800	134000	140000
	10% Strain		--	--	--	--	--	--	--	--	--	--	--
Junction Strength (lb./ft.)		GRI : GG2	--	--	--	--	--	--	--	--	--	--	--
Soil-Geosynthetic Friction		ASTM D 6706	0.8	0.8	0.8	0.8	0.8	0.8	0.8	0.8	0.8	0.8	0.8
Creep Resistance- $T_{creep}$ (lb./ft.)		ASTM D 5262	--	--	1266	2115	2975	3734	4684	6013	8674	9732	17351
Creep Reduction Factor ( $T_{lt} / T_{creep}$ )			1.6	1.6	1.58	1.58	1.58	1.58	1.58	1.58	1.58	1.58	1.58
Installation Damage (RF <sub>C</sub> )	Sand	GRI : GG4 & GT7	1.05	1.05	1.05	1.05	1.05	1.05	1.05	1.05	1.05	1.05	1.05
	Limestone		1.1	1.1	1.5	1.25	1.25	1.25	1.25	1.25	1.25	1.25	1.25
Durability (RF <sub>D</sub> )	Chemical	ASTM D 5322	1.1	1.1	1.1	1.1	1.1	1.1	1.1	1.1	1.1	1.1	1.1
	Biological	ASTM D1987, D3083, G21 & G22	1.0	1.0	1.0	1.0	1.0	1.0	1.0	1.0	1.0	1.0	1.0
Joint Strength (RF <sub>J</sub> )	Mechanical	ASTM D 6637, GRI : GG4 & GT7	--	--	--	--	--	--	--	--	--	--	--
	Overlap *	ASTM D 6706	--	--	--	--	--	--	--	--	--	--	--
Approved Application Usage			3, 4, 5	3, 4, 5	3	3	3	3	3	3	3	3	3

Approved Application Usage:

- 1 = Steepened Slopes
  - 2 = Reinforcement of Foundations over Soft Soils
  - 3 = Both Steepened Slopes & Reinforcement of Foundations over Soft Soils
  - 4 = Reinforced Embankment
  - 5 = Construction Expedient
- \* Minimum 3' Overlap

APPROVED GEOSYNTHETIC PRODUCTS  
(WOVEN GEOGRID)  
APPLICATION AND PROPERTIES

REVISIONS				2010 Interim Design Standard				Interim Date	Sheet No.
DATE	BY	DESCRIPTION	DATE	BY	DESCRIPTION	01/01/11		10 of 12	
01/01/11	RH	New Sheet.							
								GEOSYNTHETIC REINFORCED SOILS Index No. <b>501</b>	

TABLE OF EXTRUDED GEOGRID VALUES									
PROPERTY		REQUIRED TEST METHOD	TENSAR BX 4100	TENSAR BX 4200	TENSAR BX 1100	TENSAR BX 1120	TENSAR BX 1200	TENSAR BX 1220	TENSAR BX 1500
UV Stability (Min. Retained Strength @ 500 hr.)		ASTM D 4355	90%	90%	90%	100%	90%	100%	90%
Tensile Strength (lb./ft.)		ASTM D 6637							
Machine Direction	Ultimate ( $T_{ult}$ )		860	1,270	850	850	1,315	1,315	1,790
	2% Strain		240	370	280	280	410	410	580
	5% Strain		480	705	580	580	810	810	1,200
Cross Direction	Ultimate		875	1,370	1,300	1,300	1,975	1,975	2,055
	2% Strain		300	500	450	450	670	670	685
	5% Strain	635	960	920	920	1,360	1,360	1,370	
Strain @ Ultimate Tensile Strength		ASTM D 6637	10%	10%	10%	10%	10%	10%	10%
Secant Modulus @ (lb./ft.)	2% Strain		11,995	18,506	14,000	14,000	20,500	20,500	29,000
	5% Strain		9,596	14,092	11,600	11,600	16,200	16,200	27,400
	10% Strain		—	—	—	—	—	—	—
Junction Strength (lb./ft.)		GRI : GG2	90%	90%	790/1,210	93%	93%	93%	93%
Soil-Geosynthetic Friction		ASTM D 6706	—	0.95	0.90	0.90	0.90	0.90	0.90
Creep Resistance- $T_{creep}$ (lb./ft.)		ASTM D 5262	250	420	280	280	425	425	575
Creep Reduction Factor ( $T_{ult}/T_{creep}$ )			3.5	3.27	3.1	3.1	3.1	3.1	3.1
Installation Damage (RF <sub>c</sub> )	Sand	GRI : GG4 & GT7	1.10	1.10	1.10	1.10	1.10	1.10	1.10
	Limestone		1.43	1.35	1.35	1.35	1.35	1.35	1.35
Durability (RF <sub>d</sub> )	Chemical	ASTM D 5322	1.1	1.1	1.1	1.1	1.1	1.1	1.1
	Biological	ASTM D1987, D3083, G21 & G22	1.0	1.0	1.0	1.0	1.0	1.0	1.0
Joint Strength (RF <sub>j</sub> )	Mechanical	ASTM D 6637, GRI : GG4 & GT7	—	—	—	—	—	—	—
	Overlap *	ASTM D 6706	1.0	1.0	1.0	1.0	1.0	1.0	1.0
Approved Application Usage			3, 4, 5	3, 4, 5	3, 4, 5	3, 4, 5	3, 4, 5	3, 4, 5	3, 4, 5

Approved Application Usage:

- 1 = Steepened Slopes
- 2 = Reinforcement of Foundations over Soft Soils
- 3 = Both Steepened Slopes & Reinforcement of Foundations over Soft Soils
- 4 = Reinforced Embankment
- 5 = Construction Expedient
- \* Minimum 3' Overlap

APPROVED GEOSYNTHETIC PRODUCTS  
(EXTRUDED GEOGRID)  
APPLICATION AND PROPERTIES

REVISIONS

DATE	BY	DESCRIPTION	DATE	BY	DESCRIPTION
01/01/10	LJ	Changed Sheet No. from "8 of 9" to "9 of 10".			
01/01/11	RH	Changed Sheet No. from "9 of 10" to "11 of 12".			

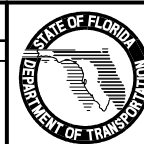

2010 Interim Design Standard

GEOSYNTHETIC REINFORCED SOILS

Interim Date	Sheet No.
01/01/11	11 of 12
Index No.	
501	

TABLE OF EXTRUDED GEOGRID VALUES

PROPERTY		REQUIRED TEST METHOD	TENSAR UX 1400 HS UX 1400 MSE UX MESA 3	TENSAR UX 1500 HS UX 1500 MSE UX MESA 4	TENSAR UX 1600 HS UX 1600 MSE UX MESA 5	TENSAR UX 1700 HS UX 1700 MSE UX MESA 6	TENAX MS 220	TENAX MS 330	COMBIGRID 30/30 Q1 151 GRK 3	SECUGRID 20/20 Q1	SECUGRID 30/30 Q1
UV Stability (Min. Retained Strength @ 500 hr.)		ASTM D 4355	90%	90%	90%	90%	85%	85%	90%	90%	90%
Tensile Strength (lb./ft.)		ASTM D 6637									
Machine Direction	Ultimate ( $T_{ult}$ )		4,790	7810	9,860	11,980	925	1,370	2,055	1,646	2,055
	2% Strain		1,100	1,850	2,330	2,740	300	418	686	549	686
	5% Strain		2,130	3,560	3,980	5,140	615	925	1,475	1,029	1,475
Cross Direction	Ultimate		—	—	—	—	1,400	2,100	2,055	1,646	2,055
	2% Strain		—	—	—	—	445	616	686	549	686
	5% Strain	—	—	—	—	890	1,340	1,475	1,029	1,475	
Strain @ Ultimate Tensile Strength		ASTM D 6637	10%	10%	10%	10%	12%	12%	8%	9%	7.5%
Secant Modulus (lb./ft.)	2% Strain		55,000	92,500	116,500	137,000	15,000	20,900	34,300	27,450	34,300
	5% Strain		42,600	71,200	79,600	102,800	12,330	18,500	29,500	20,580	29,500
	10% Strain		—	—	—	—	—	—	—	—	—
Junction Strength (lb./ft.)		GRI : GG2	90%	90%	90%	90%	835	1,230	337	549	617
Soil-Geosynthetic Friction		ASTM D 6706	0.462	0.462	0.462	0.462	—	—	0.65	0.93	0.93
Creep Resistance- $T_{creep}$ (lb./ft.)		ASTM D 5262	1,970	3,000	3,960	4,975	—	—	726	581	726
Creep Reduction Factor ( $T_{ult}/T_{creep}$ )			2.43	2.60	2.49	2.41	3.5	3.5	2.83	2.83	2.83
Installation Damage (RF <sub>C</sub> )	Sand	GRI : GG4 & GT7	1.10	1.10	1.10	1.10	1.1	1.1	1.1	1.1	1.1
	Limestone		1.20	1.20	1.20	1.20	1.1	1.1	1.1	1.1	1.1
Durability (RF <sub>D</sub> )	Chemical	ASTM D 5322	1.1	1.1	1.1	1.1	1.1	1.1	1.1	1.1	1.1
	Biological	ASTM D1987, D3083, G21 & G22	1.0	1.0	1.0	1.0	1.0	1.0	1.0	1.0	1.0
Joint Strength (RF <sub>J</sub> )	Mechanical	ASTM D 6637, GRI : GG4 & GT7	1.0	1.0	1.0	1.0	1.0	1.0	—	—	—
	Overlap *	ASTM D 6706	1.0	1.0	1.0	1.0	1.0	1.0	1.0	1.0	1.0
Approved Application Usage			3	3	3	3	2, 5	2, 5	2, 5	2, 5	2, 5

Approved Application Usage:  
 1 = Steepened Slopes  
 2 = Reinforcement of Foundations over Soft Soils  
 3 = Both Steepened Slopes & Reinforcement of Foundations over Soft Soils  
 4 = Reinforced Embankment  
 5 = Construction Expedient  
 \* Minimum 3' Overlap

APPROVED GEOSYNTHETIC PRODUCTS  
 (EXTRUDED GEOGRID)  
 APPLICATION AND PROPERTIES

REVISIONS

DATE	BY	DESCRIPTION	DATE	BY	DESCRIPTION
01/01/10	LJ	Changed Sheet No. from "9 of 9" to "10 of 10".			
01/01/11	RH	Changed Sheet No. from "10 of 10" to "12 of 12".			

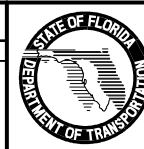

2010 Interim Design Standard

GEOSYNTHETIC REINFORCED SOILS

Interim Date	Sheet No.
01/01/11	12 of 12
Index No.	
501	