

NOTE: Alt. B Structure Bottom Only. See Index No. 200 for structure bottom details and hole reinforcement. (For Pipes 30" Dia. And Larger)

**INLET WITH STRUCTURE BOTTOM**

RECOMMENDED MAXIMUM PIPE SIZES	
Inlet Inside Width	Pipe Size
2'-11" Or 3'-3"	24"
4'-0" Or 3'-10"	30"

Note: Recommended sizes are for concrete pipe. Sizes for other types of pipe must be verified for fit in accordance with Index No. 201. For larger pipe see bottom detail above and Index No. 200.

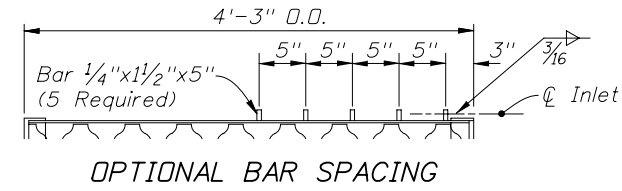

**OPTIONAL BAR SPACING**

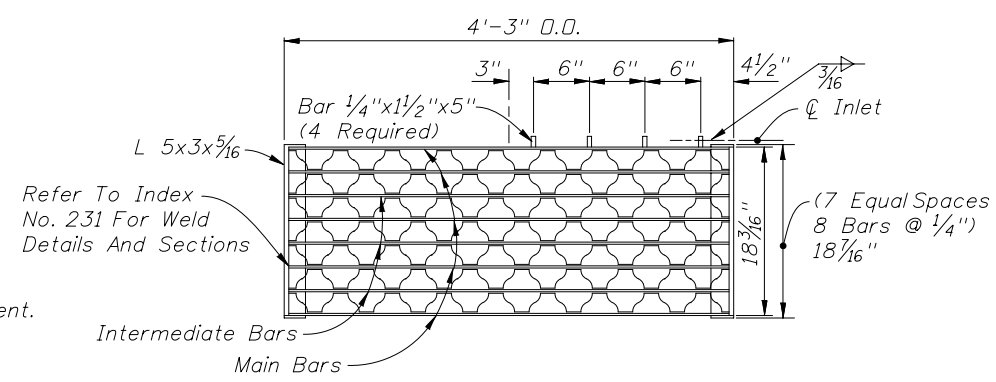

**TWO REQUIRED PER INLET**

5" Steel Grate:  
Main Bars 5" x 1/4"  
Intermediate Bars 1 1/2" x 1/4"  
Reticuline Bars 1 1/4" x 3/16"

Steel Grate : Manufactured By Borden, Florida Steel, U.S. Foundry Irving, Reliance, Greulich (Or Equal).

**STEEL GRATE**

- GENERAL NOTES**
1. This inlet is suitable for village swales, ditches, or other areas subject to heavy wheelloads, minimum debris, and bicycle traffic. This inlet may be placed in areas subject to occasional pedestrian traffic such as landscaped areas and pavement areas where pedestrians can walk around the inlet.
  2. When alternate "G" grate is specified in plans, the grate is to be hot dip galvanized after fabrication.
  3. All reinforcing is Grade 60 bars with 2" min. cover unless otherwise noted. See Index No. 201 for equivalent area of welded wire fabric. Cut or bend bars out of way of pipe to clear pipe 1/2".
  4. All exposed edges and corners shall be 3/4" chamfer or tooled to 1/4" radius.
  5. All dimensions are for both precast and cast-in-place inlets unless otherwise noted.
  6. For supplementary details see Index No. 201.
  7. Inlet to be paid for under the contract unit price for Inlets (Gutter Type V), EA

WALL DEPTH	SCHEDULE	AREA (in. <sup>2</sup> /ft.)	MAX. SPACING	
			BARS	WWF
0' - 5'	A12	0.20	12"	8"
5' - 9'	A6	0.20	6"	5"
9' - 12'	A4	0.20	4"	3"
9' - 15'	B5.5	0.24	5 1/2"	5"

**HORIZONTAL WALL REINFORCING SCHEDULE (TABLE 1)**

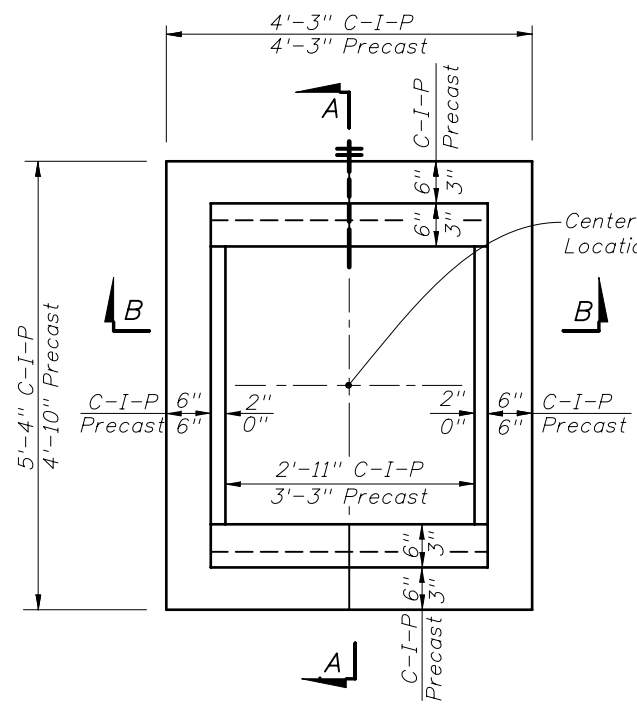

**PLAN**  
(CAST-IN-PLACE INLET SHOWN WITHOUT GRATE; PRECAST INLET SIMILAR)

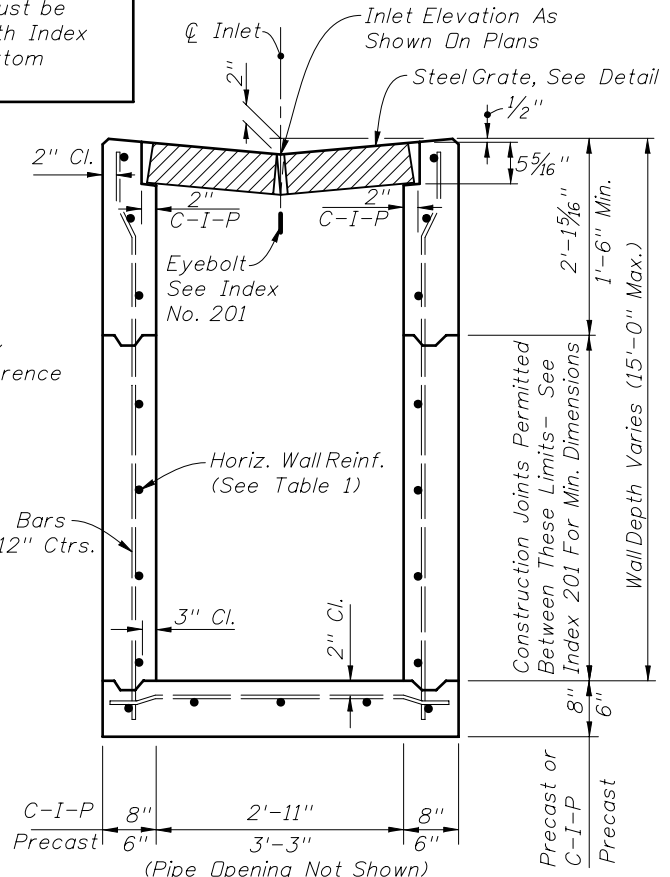

**SECTION BB**  
(CAST-IN-PLACE INLET SHOWN PRECAST INLET SIMILAR)

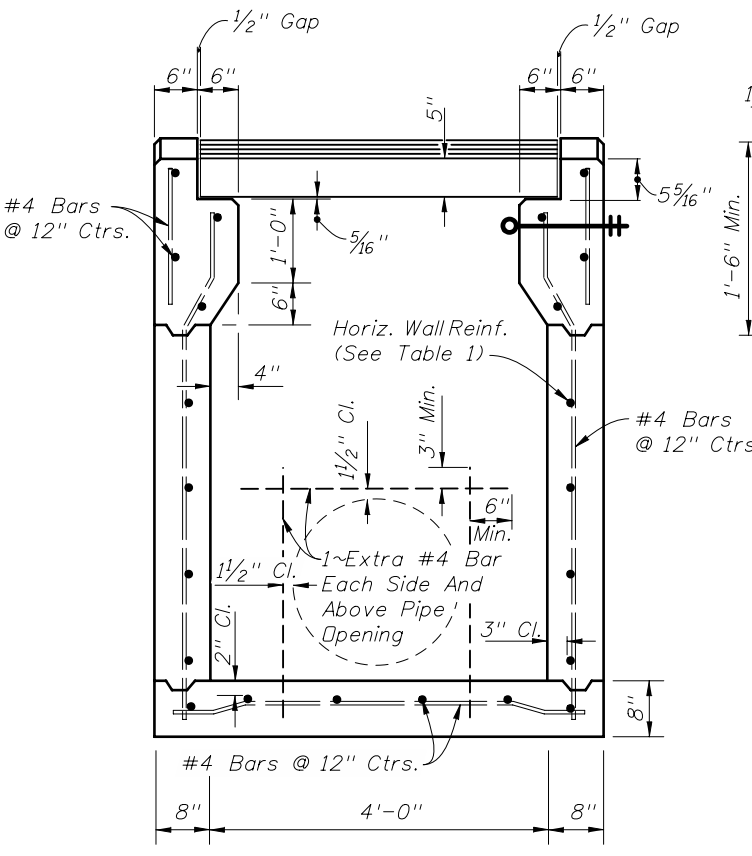

**SECTION AA**  
(CAST-IN-PLACE INLET)

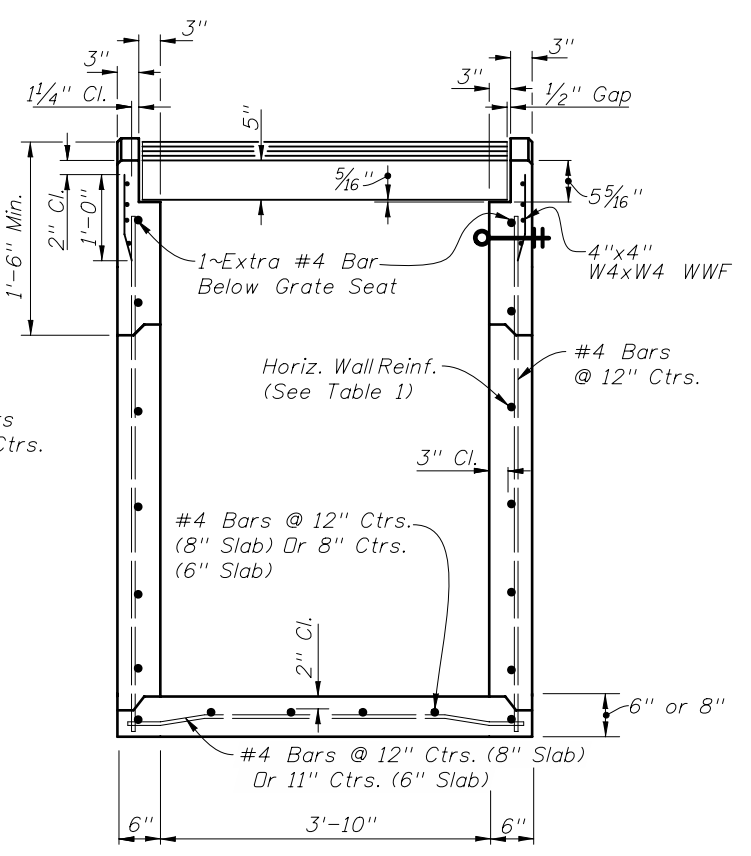

**SECTION AA**  
(PRECAST INLET)

REVISIONS					
DATE	BY	DESCRIPTION	DATE	BY	DESCRIPTION
05/12/09	SJN	Clarify recess depth of top of inlet for steel grate.			

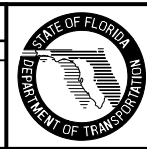

2010 Interim Design Standard

**GUTTER INLET TYPE V**

Interim Date	Sheet No.
01/01/10	1 of 2
Index No.	
<b>221</b>	