

**TYPICAL SECTION THRU STRIP SEAL EXPANSION JOINT**  
 (Begin or End Concrete Girder Bridge shown,  
 Intermediate Supports and Steel Girder Bridge similar.  
 Reinforcing Steel and Girder details not shown for clarity.)

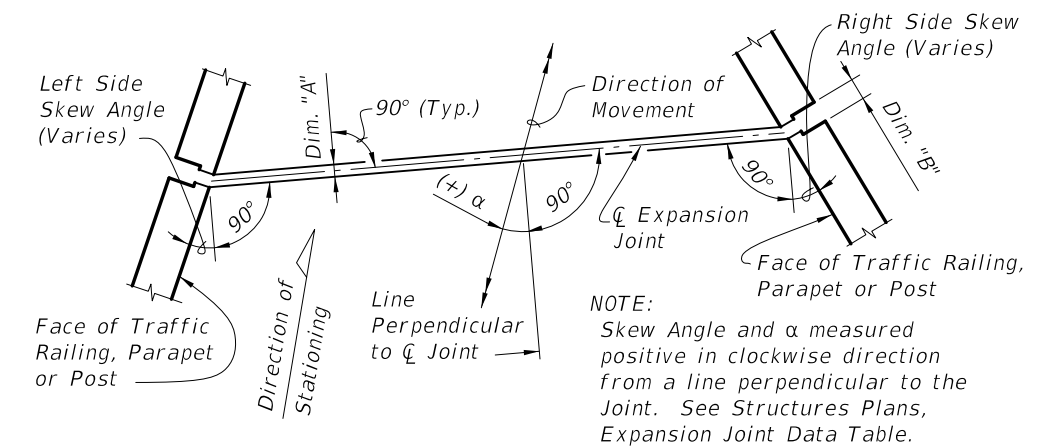

**MOVEMENT SCHEMATIC**

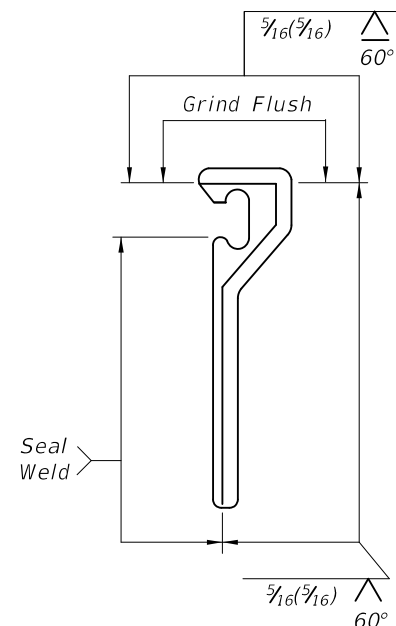

**SHOP SPLICE DETAIL**

**GENERAL NOTES:**

1. Furnish Strip Seal Expansion Joint Systems in accordance with Specification Section 458.
2. Shape of Edge Rail shown is representative, minor variations depending on manufacturer are permitted.
3. Recess the Edge Rail below the concrete surface in accordance with Specification Section 458.
4. Refer to Specification 458 and the Expansion Joint Data Table in the Structures Plans for installation and fabrication requirements and adjustments to Dimension "A".
5. Manufacturers seeking approval of Strip Seal Expansion Joint Systems for inclusion on the Qualified Products List as pre-approved designs must submit application along with design documentation showing the expansion joint meets the specification, geometric and material requirements specified herein. Include installation details consisting of temporary or sacrificial support brackets, bolts, clamps, etc. that are compatible with decks constructed with or without blockouts.

**REVISIONS**

DATE	BY	DESCRIPTION	DATE	BY	DESCRIPTION
07/01/10	GJM	Deleted INSTRUCTIONS TO DESIGNER & Diaphragm related details.			
01/01/11	CMH	Deleted Notes 3 & 4; Changed Notes 1 & 2; Moved MOVEMENT SCHEMATIC from sheet 2 to sheet 1.			

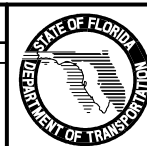

2010 Interim Design Standard

**STRIP SEAL EXPANSION JOINT**

Interim Date	Sheet No.
01/01/11	1 of 3
Index No.	
<b>21100</b>	

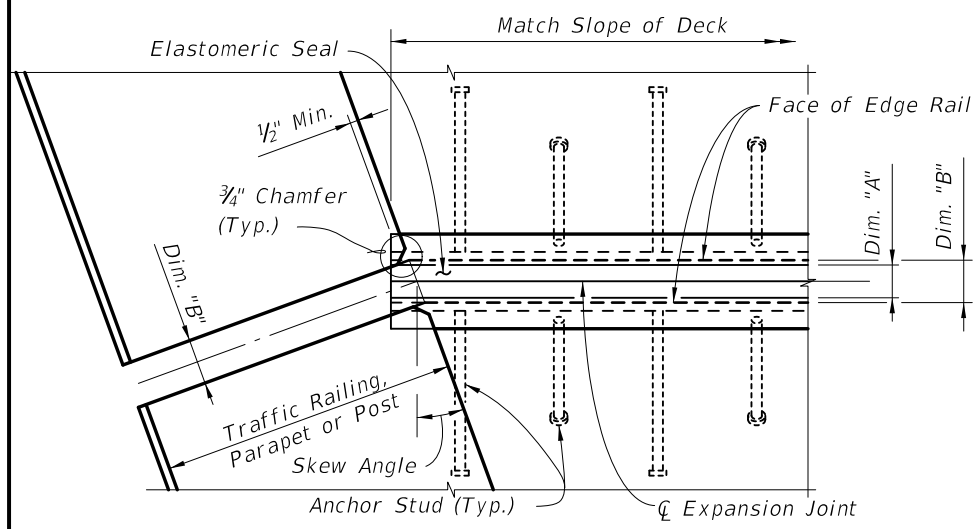

PARTIAL PLAN VIEW OF SKEWED JOINTS

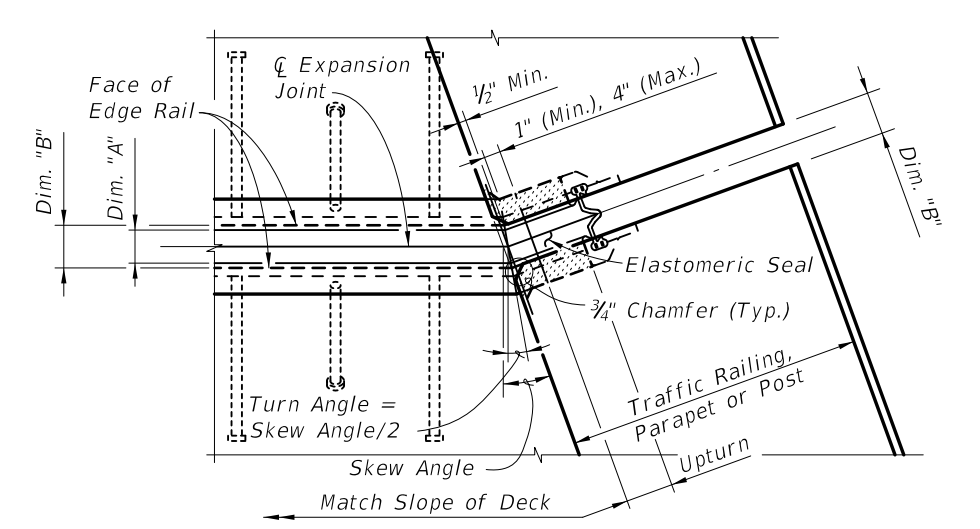

PARTIAL PLAN VIEW OF JOINTS SKEWED GREATER THAN 6°

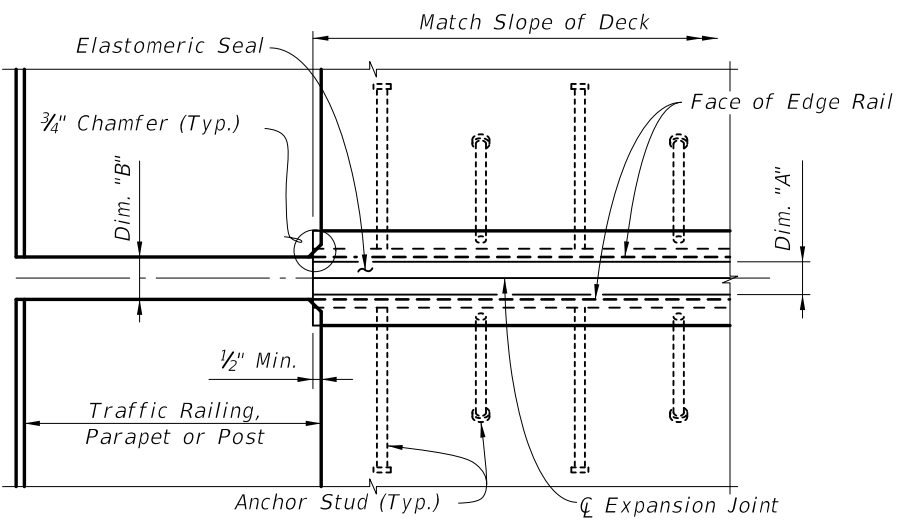

PARTIAL PLAN VIEW OF NONSKEWED JOINTS

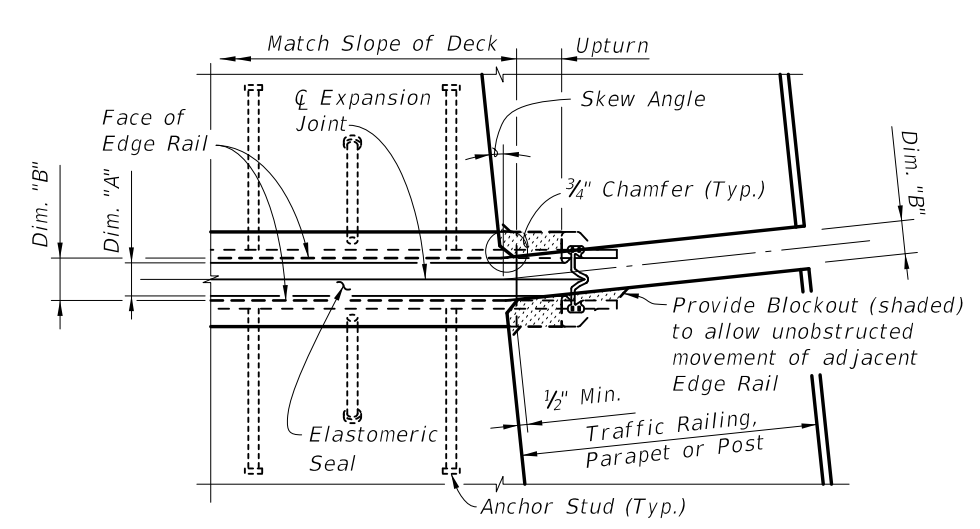

PARTIAL PLAN VIEW OF NONSKEWED JOINTS & JOINTS SKEWED 6° OR LESS

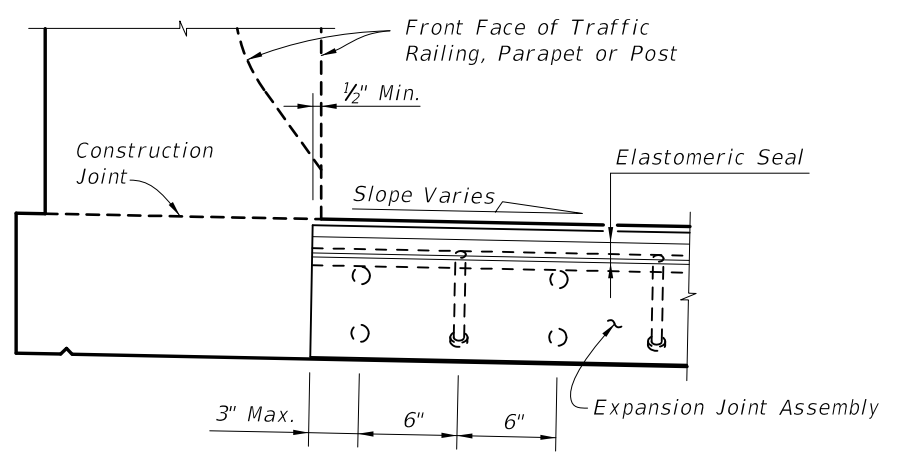

PARTIAL SECTION ALONG Q̄ JOINT

JOINT TREATMENT AT HIGH SIDE OF DECK WITH SLOPE ≥ 2%  
(Sidewalk Cover Plate where applicable not shown for clarity)

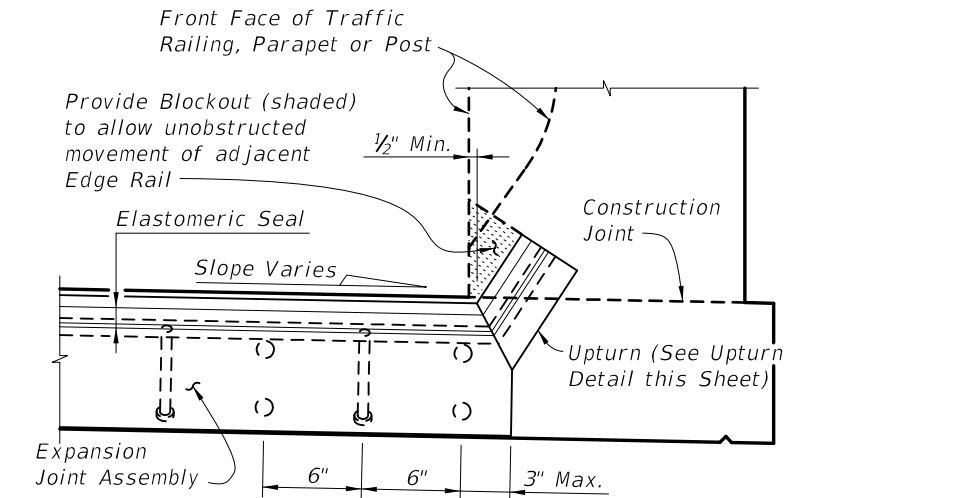

PARTIAL SECTION ALONG Q̄ JOINT

JOINT TREATMENT AT LOW SIDE OF DECK & HIGH SIDE OF DECK WITH SLOPE < 2%  
(Sidewalk Cover Plate where applicable not shown for clarity)

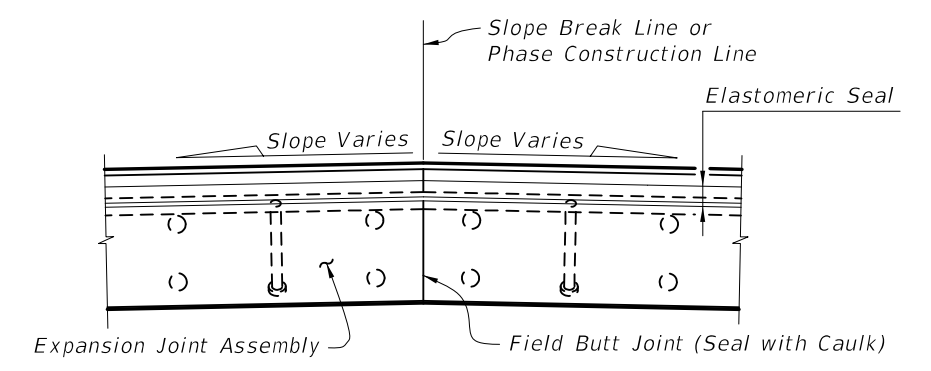

PARTIAL SECTION ALONG Q̄ JOINT AT FIELD BUTT JOINT LOCATION (CROWNED DECK OR SLAB SHOWN)

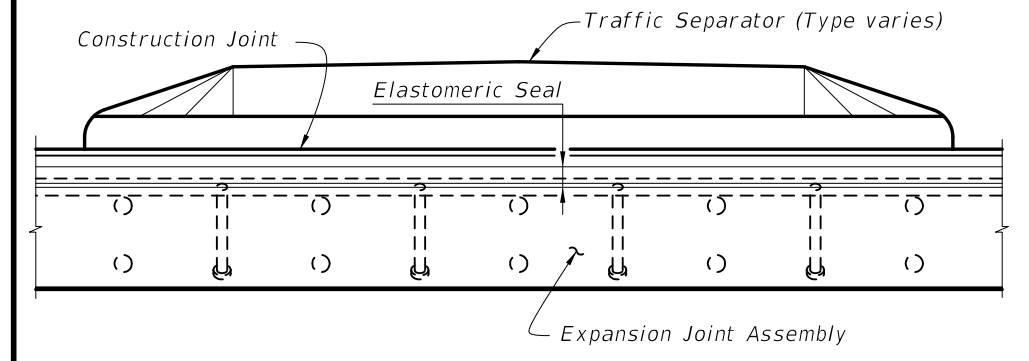

PARTIAL SECTION ALONG Q̄ JOINT THRU TRAFFIC SEPARATOR

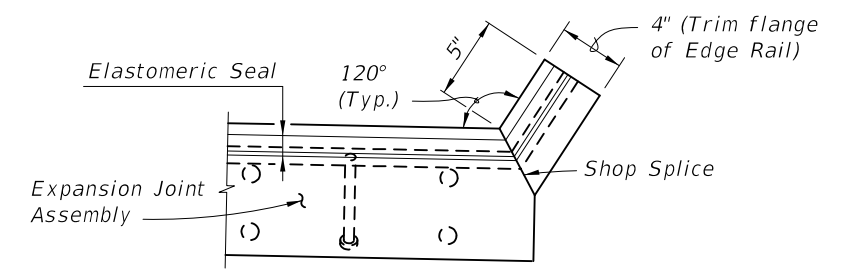

UPTURN DETAIL (TYPICAL AT TRAFFIC BARRIERS AND PARAPETS)

REVISIONS

DATE	BY	DESCRIPTION	DATE	BY	DESCRIPTION
01/01/10	SJN	Changed MOVEMENT SCHEMATIC detail.			
01/01/11	CMH	Moved MOVEMENT SCHEMATIC detail to sheet 1.			

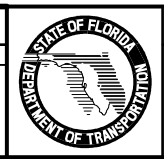

2010 Interim Design Standard

STRIP SEAL EXPANSION JOINT

Interim Date	Sheet No.
01/01/10	2 of 3
Index No.	
21100	