

TYPICAL SECTION THRU STRIP SEAL EXPANSION JOINT
 (Begin or End Concrete Girder Bridge shown,
 Intermediate Supports and Steel Girder Bridge similar.
 Reinforcing Steel and Girder details not shown for clarity.)

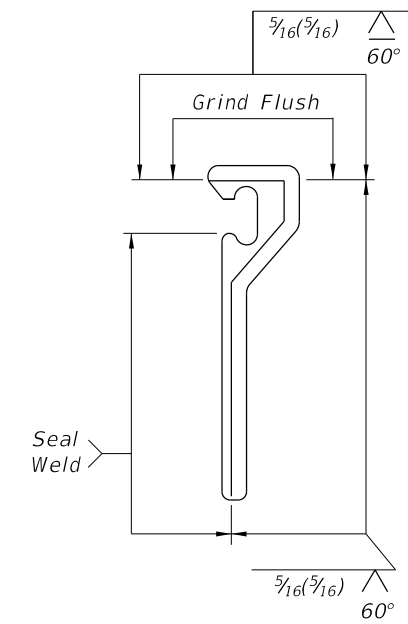

SHOP SPLICE DETAIL

GENERAL NOTES:

1. Furnish Strip Seal Expansion Joint Systems in accordance with Specification Section 458, ASTM D5973 and the AASHTO LRFD Bridge Design Specifications.
2. Furnish solid steel Edge Rails in accordance with ASTM A709, Grade 36, 50 or 50(W) that are extruded, hot rolled and or machined. Furnish Edge Rails with a minimum mass of 19.2 lb/ft excluding studs, a minimum height of 8", a minimum thickness of 1/2" and a maximum top surface (riding surface) width of 2". Shape of Edge Rail shown is representative, minor variations depending on manufacturer are permitted. Edge Rails manufactured from bent plate or built up pieces are not acceptable.
3. Furnish Anchor Studs in accordance with ASTM A108. Electric arc end-weld Anchor Studs with complete fusion. Anchor Studs may be piggy backed to achieve required lengths.
4. When required, furnish 1/4" thick slip resistant steel Sidewalk Cover Plates in accordance with ASTM A709, Grade 36 or 50, with a minimum coefficient of friction on the top surface of 0.8 in a dry condition as determined by ASTM F1677 or F1679 and 0.68 or 0.52 in a wet condition as determined by ASTM F1679 or ASTM F1677 (respectively); that incorporate an anti-slip steel surface consisting of a random hatch matrix or other suitable pattern. Do not use diamond plate or surface applied slip resistant tapes, films, nonmetallic coatings or other similar materials. Furnish flat head Stainless Steel Sleeve Anchors in accordance with ASTM F593 Group 1 Alloy 304 for attaching Sidewalk Cover Plates. Install Sleeve Anchors in accordance with manufacturer's recommendations.
5. Recess the Edge Rail below the concrete surface in accordance with Specification Section 458.
6. Refer to Specification 458 and the Expansion Joint Data Table in the Structures Plans for installation and fabrication requirements and adjustments to Dimension "A".
7. Manufacturers seeking approval of Strip Seal Expansion Joint Systems for inclusion on the Qualified Products List as pre-approved designs must submit application along with design documentation showing the expansion joint meets the specification, geometric and material requirements specified herein. Include installation details consisting of temporary or sacrificial support brackets, bolts, clamps, etc. that are compatible with decks constructed with or without blockouts.

REVISIONS					
DATE	BY	DESCRIPTION	DATE	BY	DESCRIPTION
07/01/10	GJM	Deleted INSTRUCTIONS TO DESIGNER and Diaphragm related details.			

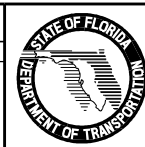

2010 Interim Design Standard

STRIP SEAL EXPANSION JOINT

Interim Date	Sheet No.
07/01/10	1 of 3
Index No.	
21100	