

PARTIAL PLAN VIEW OF SKEWED JOINTS

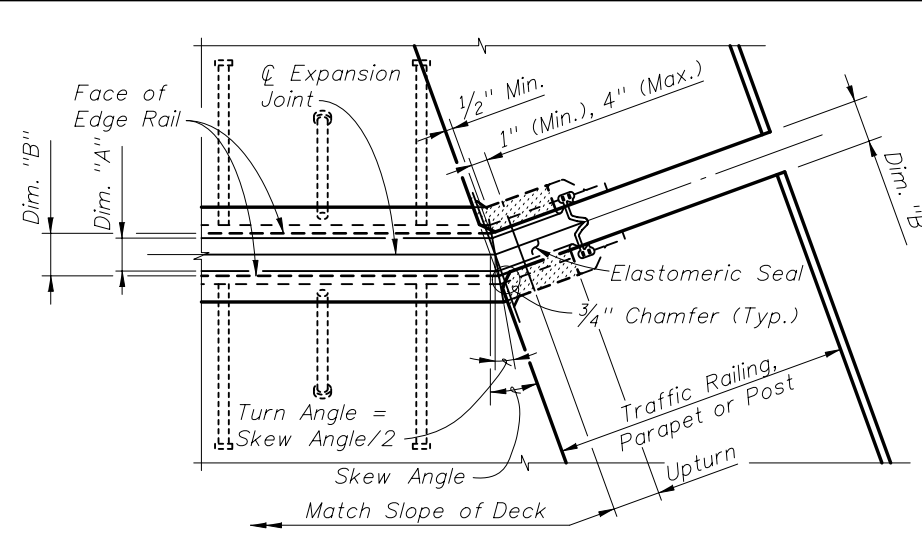

PARTIAL PLAN VIEW OF JOINTS SKEWED GREATER THAN 6°

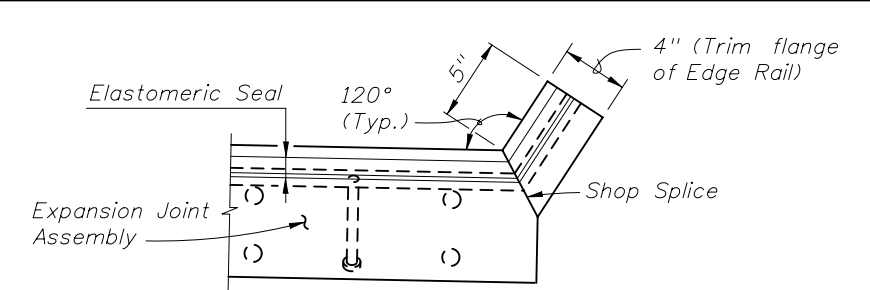

UPTURN DETAIL (TYPICAL AT TRAFFIC BARRIERS AND PARAPETS)

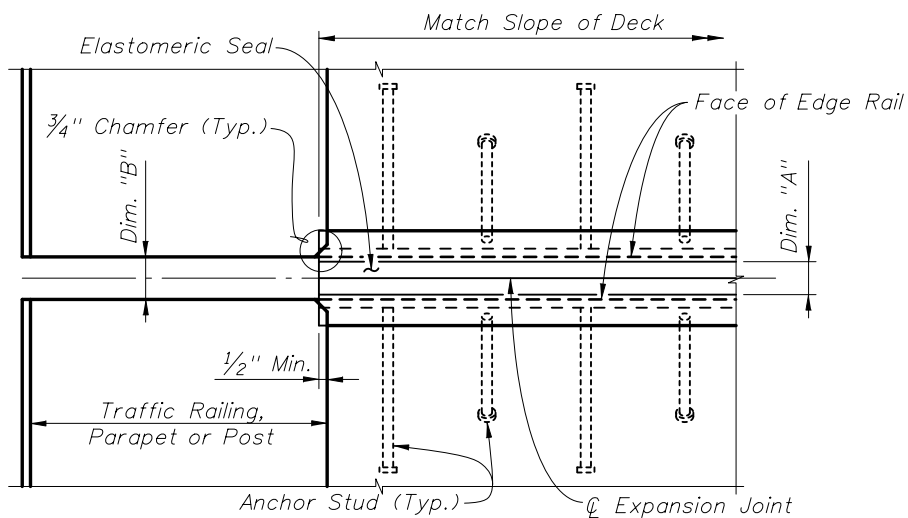

PARTIAL PLAN VIEW OF NONSKEWED JOINTS

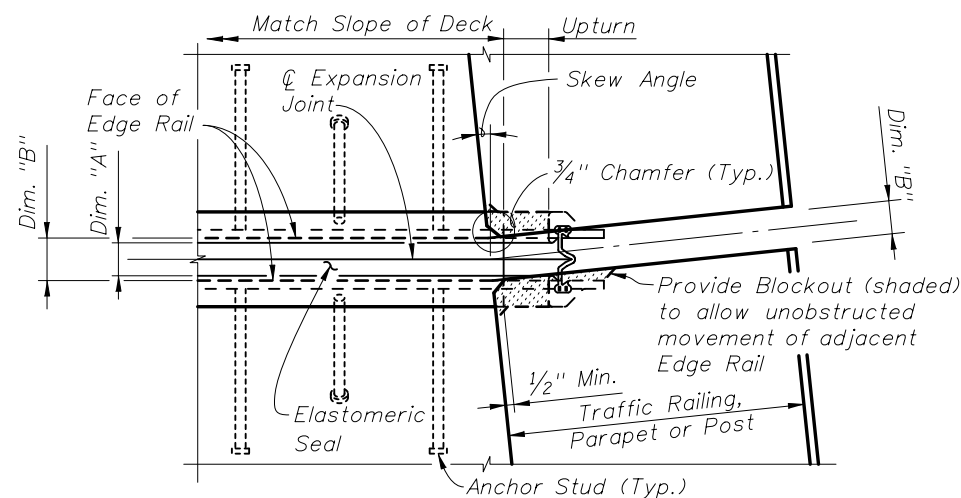

PARTIAL PLAN VIEW OF NONSKEWED JOINTS & JOINTS SKEWED 6° OR LESS

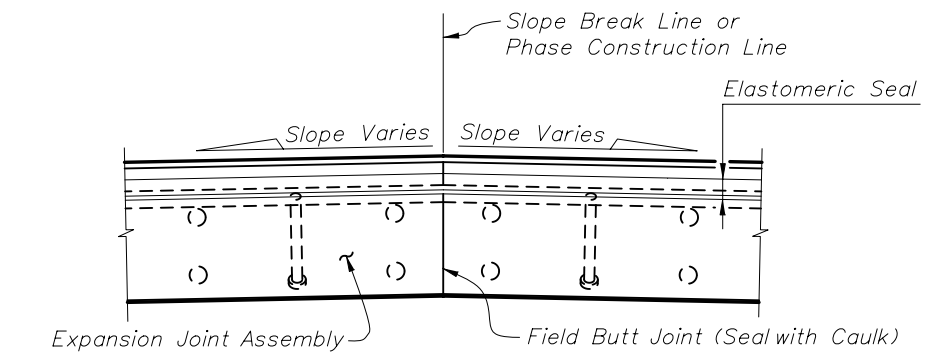

PARTIAL SECTION ALONG Q JOINT AT FIELD BUTT JOINT LOCATION (CROWNED DECK OR SLAB SHOWN)

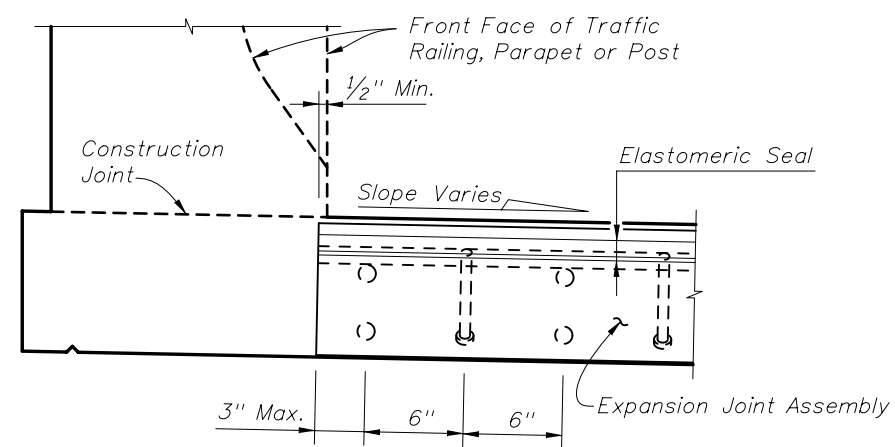

PARTIAL SECTION ALONG Q JOINT

JOINT TREATMENT AT HIGH SIDE OF DECK WITH SLOPE $\geq 2\%$
(Sidewalk Cover Plate where applicable not shown for clarity)

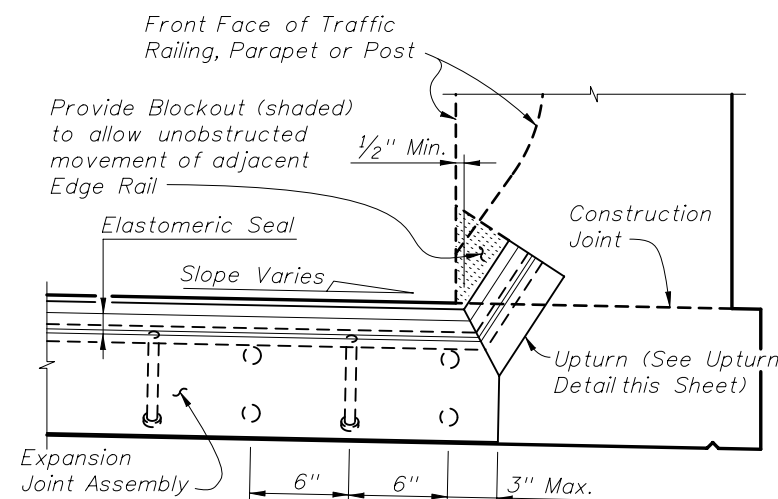

PARTIAL SECTION ALONG Q JOINT

JOINT TREATMENT AT LOW SIDE OF DECK & HIGH SIDE OF DECK WITH SLOPE $< 2\%$
(Sidewalk Cover Plate where applicable not shown for clarity)

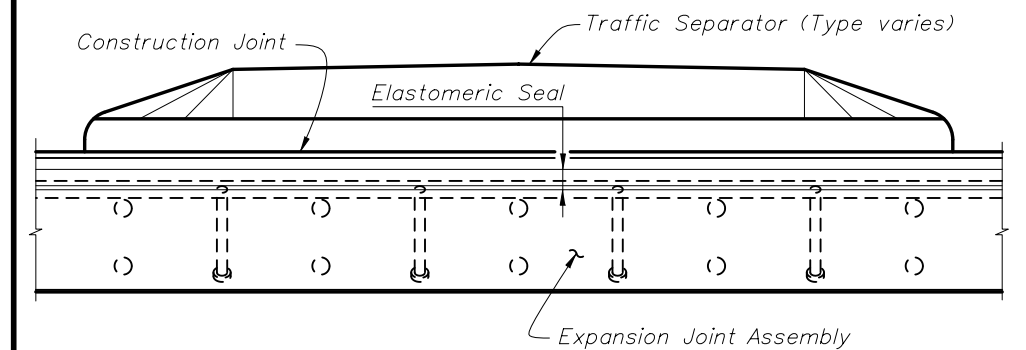

PARTIAL SECTION ALONG Q JOINT THRU TRAFFIC SEPARATOR

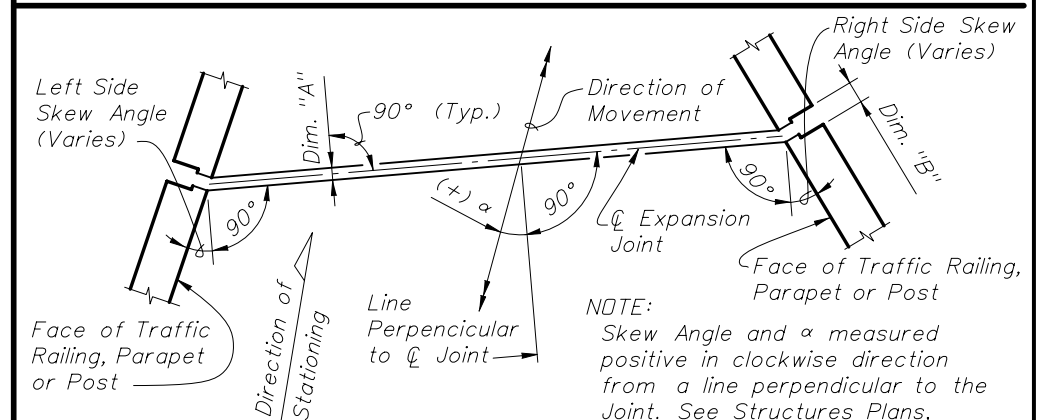

NOTE: Skew Angle and α measured positive in clockwise direction from a line perpendicular to the joint. See Structures Plans, Expansion Joint Data Table.

MOVEMENT SCHEMATIC

REVISIONS

DATE	BY	DESCRIPTION	DATE	BY	DESCRIPTION
01/01/10	SJN	Changed MOVEMENT SCHEMATIC detail			

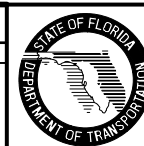

2010 Interim Design Standard

STRIP SEAL EXPANSION JOINT

Interim Date
01/01/10
Sheet No.
2 of 3
Index No.
21100