

PULL BOX

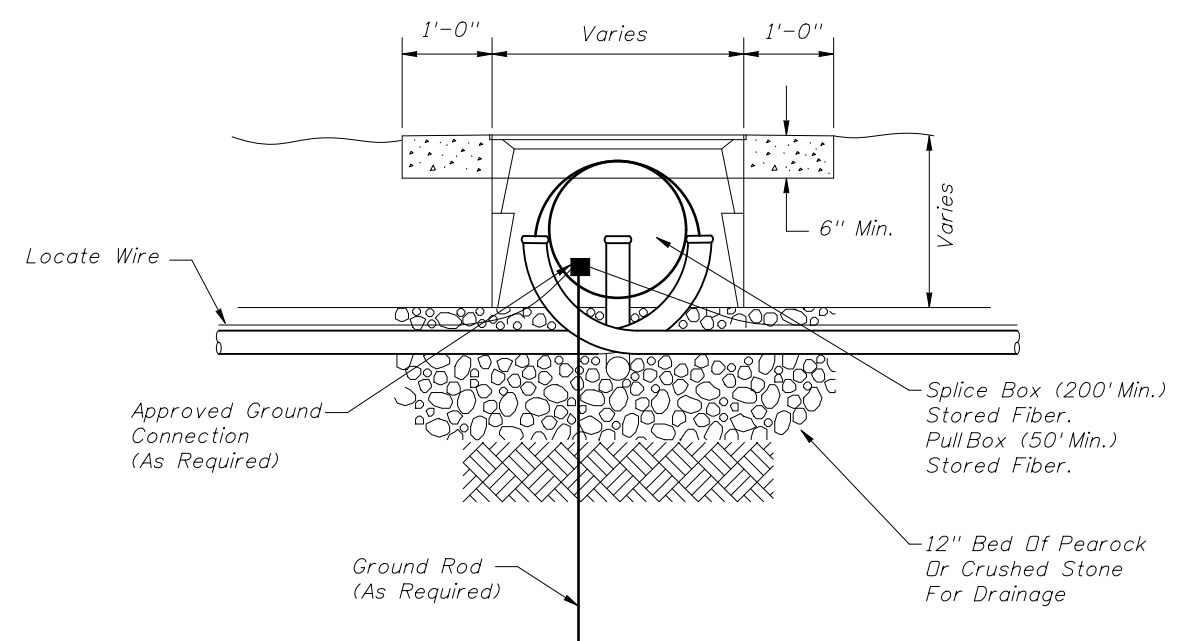
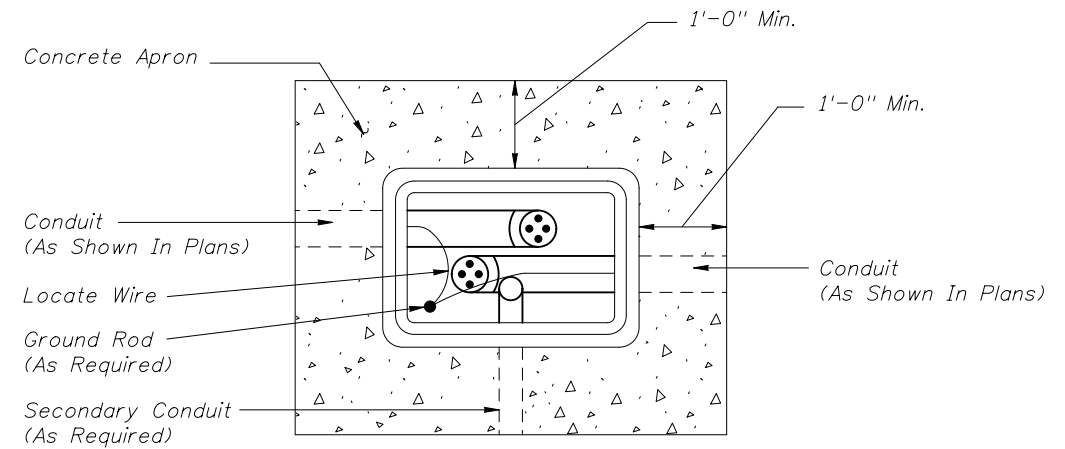

FIBER OPTIC BOX

1. Boxes shall not be installed in roadways or driveways.
2. Boxes shall be on the Approved Product List (APL).
3. Boxes shall be installed flush with the finished grade surface.
4. Fiber Optic splice boxes shall be provided with cable hanger racks designed to support cables and splice enclosures. Cost of racks to be included in cost of splice box.
5. Fiber optic boxes shall contain only Fiber Optic Cable, Conduit, and Locate Wire.
6. Conduit center line shall be aligned to top edge of box to facilitate cable pulling.
7. All boxes shall have 1'-0" wide (min) concrete apron. Concrete for concrete aprons shall be Class NS with a minimum strength at 28 days of $f'c=2.5$ Ksi. Aprons shall be sloped away from box. Cost of apron to be included in the cost of each box.
8. Prevent the ingress of Water, Dirt, Sand, and other foreign materials into the conduit prior to, during and after construction using a foam-sealing material, rubber plug, or other device designed for this application and approved.

REVISIONS

DATE	BY	DESCRIPTION	DATE	BY	DESCRIPTION
07/01/10	CH	New sheet added to Standards (07/01/10)			
01/01/11	CH	Revisions to notes and minor detail changes.			

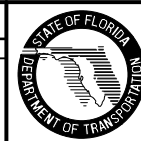

2010 Interim Design Standard

PULL, SPLICE AND JUNCTION BOX DETAILS

Interim Date	Sheet No.
01/01/11	1 of 1
Index No.	
17700	