

SECTION C-C
(RAILS NOT SHOWN)

POST "A" DETAILS FOR SPECIAL HEIGHT BICYCLE RAILING ON CONCRETE PARAPET (INDEX NO. 820)

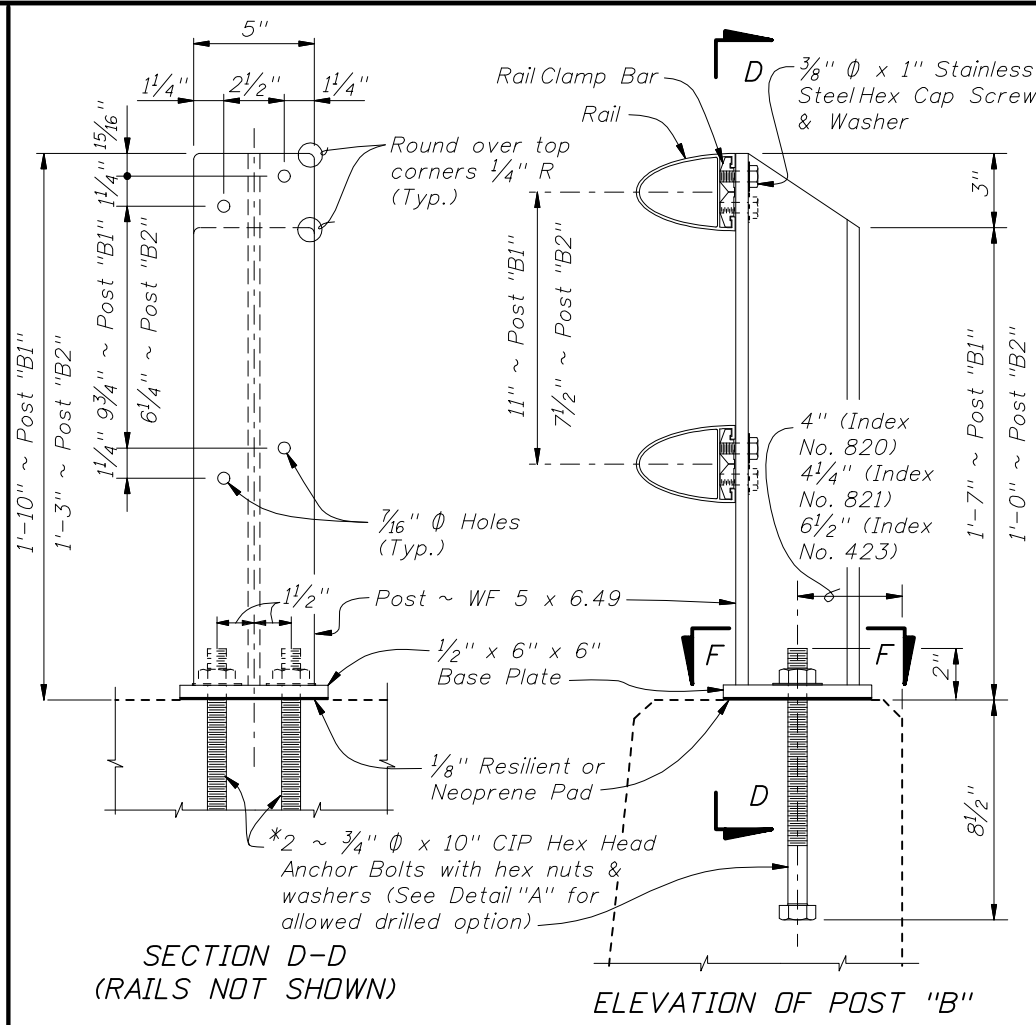

SECTION D-D
(RAILS NOT SHOWN)

ELEVATION OF POST "B"

POST "B1" DETAILS FOR SPECIAL HEIGHT BICYCLE RAILING ON TRAFFIC RAILINGS (INDEX NO. 423 AND 821) AND POST "B2" DETAILS FOR PEDESTRIAN/BICYCLE RAILING ON CONCRETE PARAPETS (INDEX NO. 820)

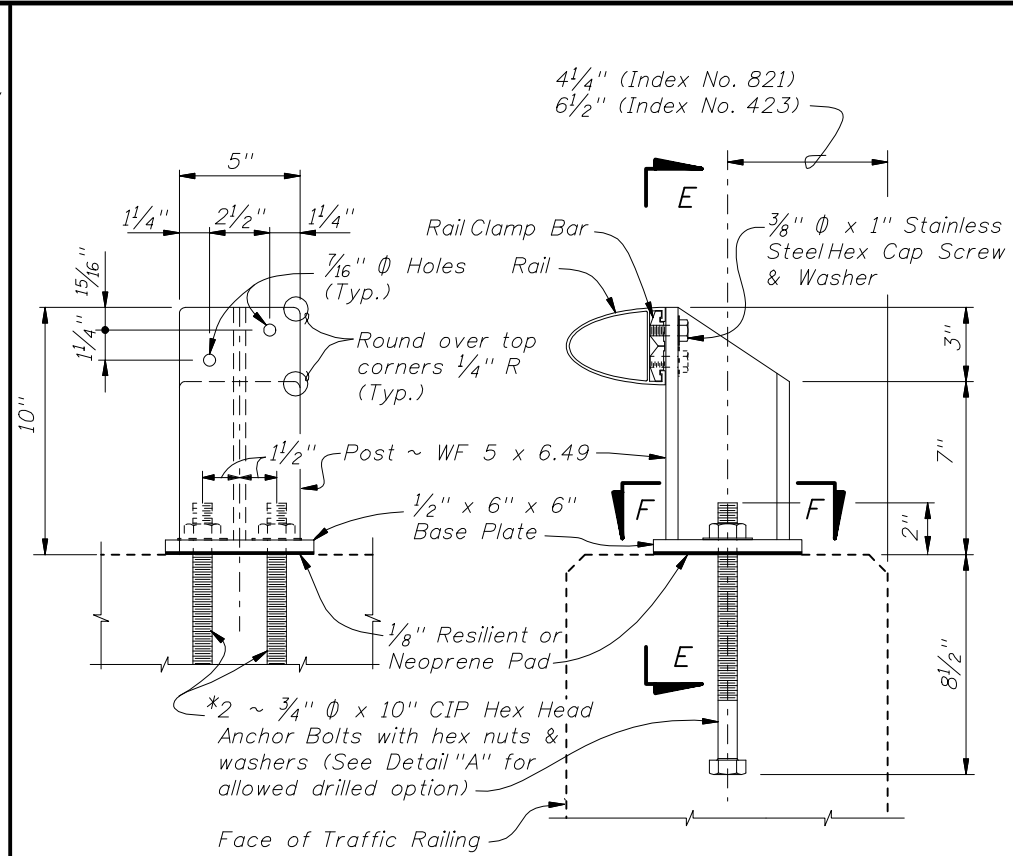

SECTION E-E
(RAIL NOT SHOWN)

ELEVATION OF POST "C"

POST "C" DETAILS FOR PEDESTRIAN/BICYCLE RAILING ON TRAFFIC RAILINGS (INDEX NO. 423 AND 821)

NOTE: After nuts have been tightened, the bolt threads shall be deformed to prevent removal of nuts. Tack welding of nuts to anchor bolts, to prevent theft, is permitted. Coat deformed or tack welded threads with a galvanizing compound in accordance with Section 562 of the Specifications.

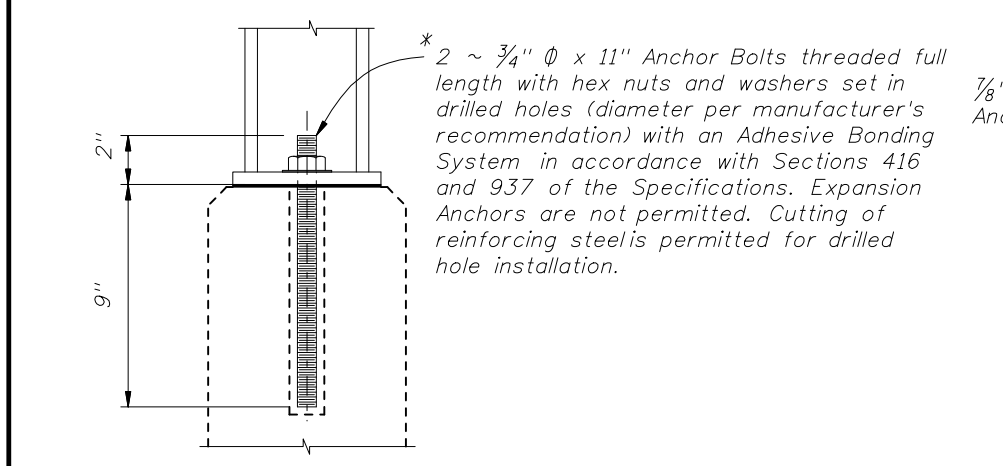

ALTERNATE ANCHOR BOLT DETAIL "A"
(CONCRETE PARAPET SHOWN, TRAFFIC RAILINGS SIMILAR)

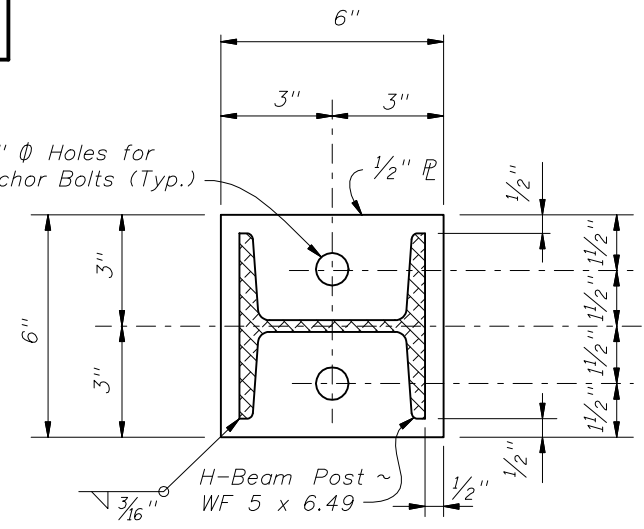

SECTION F-F
BASE PLATE DETAIL

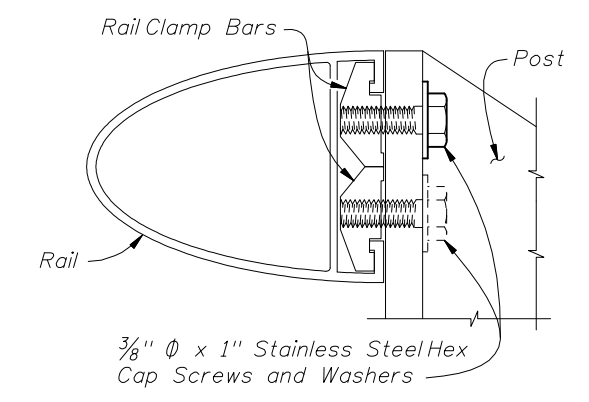

RAIL TO POST CONNECTION DETAIL

CROSS REFERENCES:

For Post "A" and Post "B2" spacing see Index No. 820.

For Post "B1" & Post "C" spacing see Index Nos. 423 or 821.

For Rail Details and Notes see Index No. 822, Sheet 2.

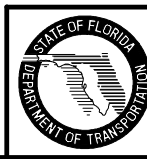

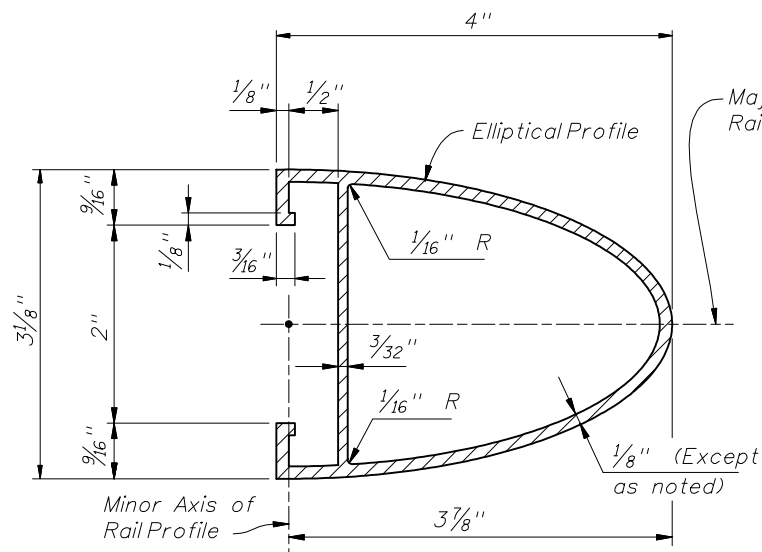

SECTION A-A
(TYPICAL SECTION THRU RAIL)

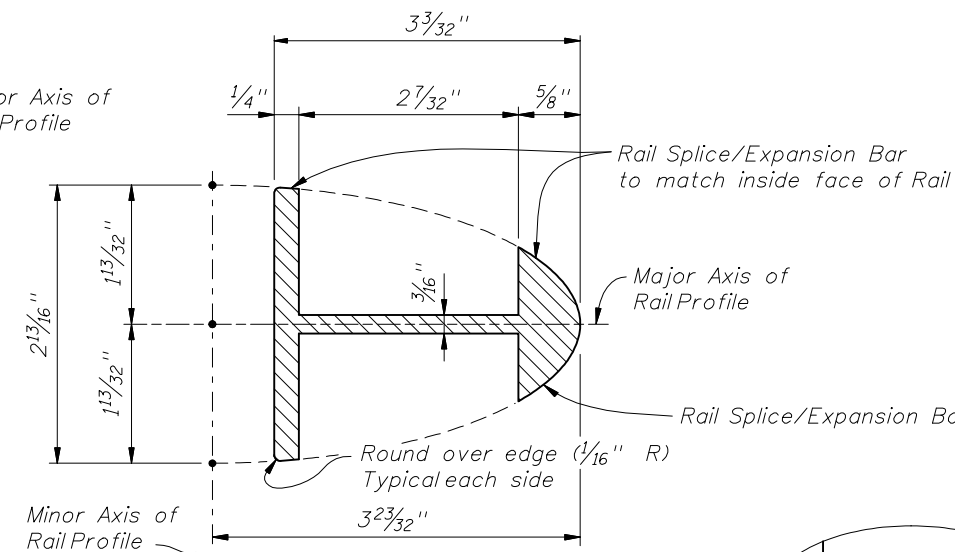

SECTION B-B - RAIL SPLICE/EXPANSION BAR
(RAIL NOT SHOWN FOR CLARITY)

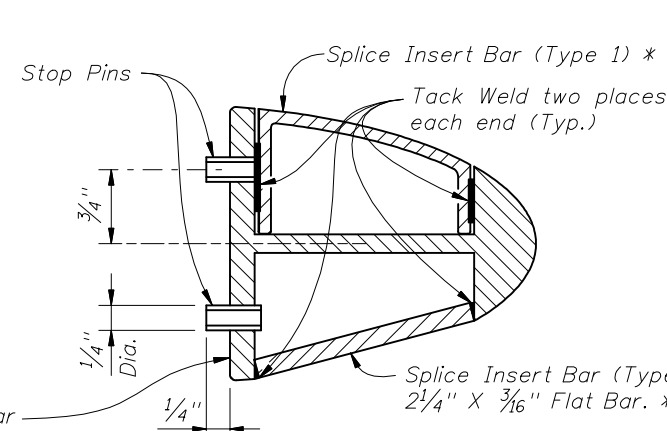

SECTION C-C

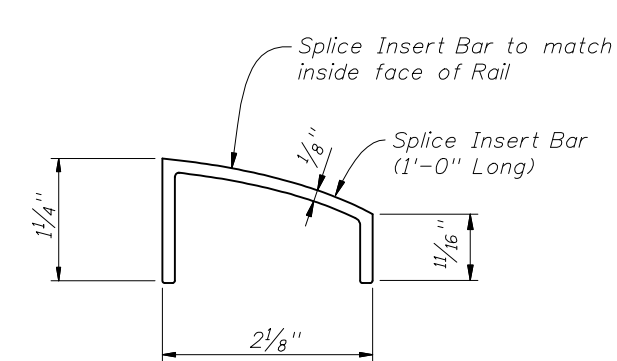

SPLICE INSERT BAR DETAIL (TYPE 1)

* Use of either Type 1 or Type 2 Splice Insert Bars is at the option of the Contractor.

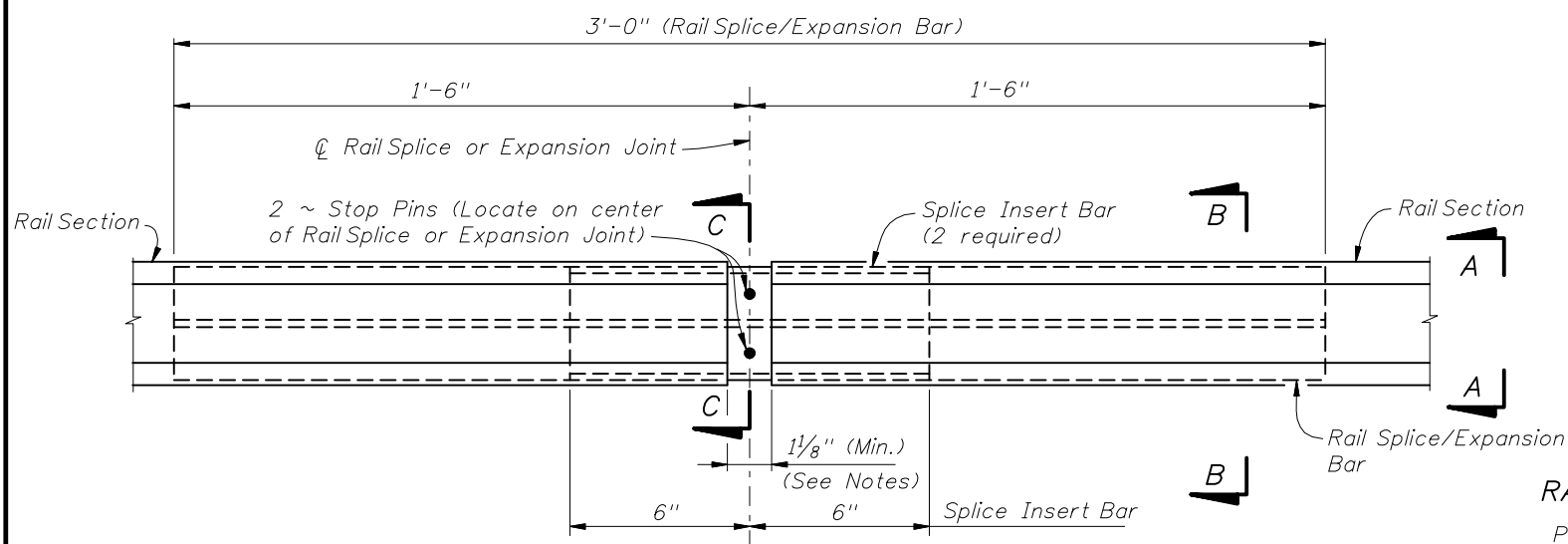

RAIL SPLICE ASSEMBLY DETAIL (TYPICAL AT BRIDGE EXPANSION JOINTS AND RAIL SPLICE LOCATIONS)

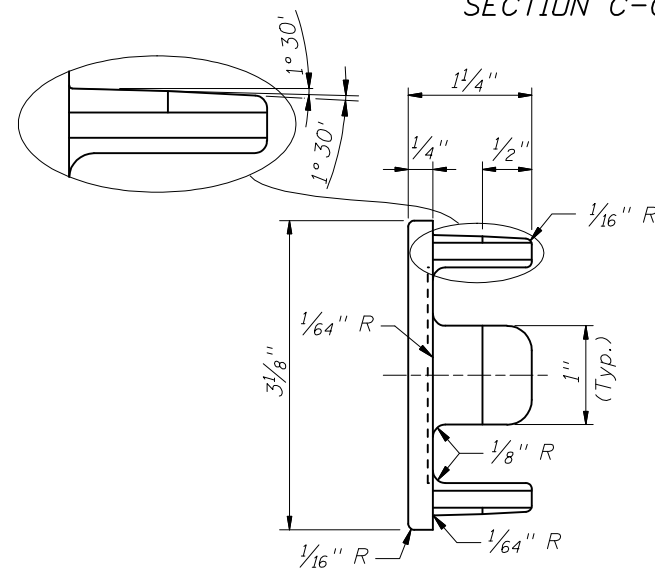

VIEW D-D

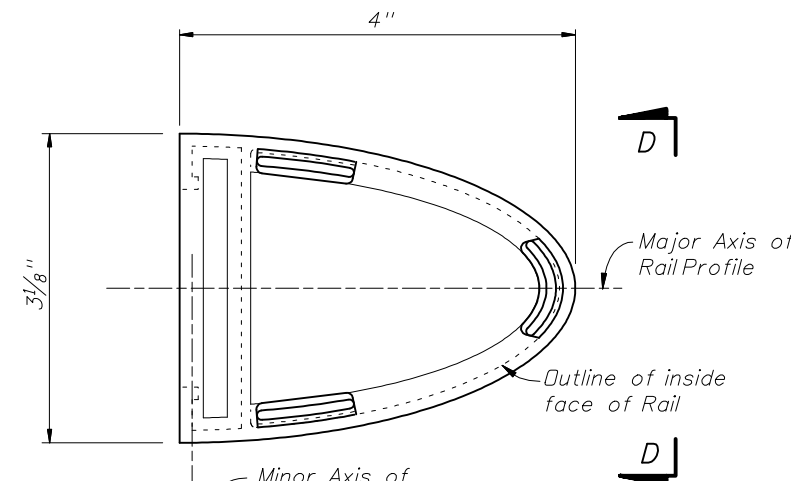

RAIL END CAP DETAIL

NOTE: Provide for drive fit.

RAILING NOTES:

- PAYMENT:** Payment for the railing includes Rails, Posts, Rail Splice Assemblies, Rail Clamp Bars, Rail End Caps, Anchor Bolts, Nuts, Resilient Pads, Screws and Washers and all incidental materials and labor required to complete the installation.
- POST ASSEMBLY:** Fabricated wrought aluminum; Post - ASTM B221, alloy 6061-T6, or alloy 6351-T5; Base Plate - ASTM B209, alloy 6061-T6.
- WELDING:** Welding of aluminum components shall be in accordance with ANSI and AWS D1.2 "Structures Welding Code - Aluminum".
- RAIL AND RAIL SPLICE ASSEMBLIES:** Aluminum; ASTM B221, alloy 6061-T6, or alloy 6351-T5. Stop Pins shall be press-fit Aluminum or Stainless Steel pins or tubes, unless otherwise approved by the Engineer.
- RAIL CLAMP BAR:** Aluminum; ASTM B221, alloy 6061-T6, or alloy 6351-T5.
- STAINLESS STEEL FASTENERS:** 3/8" Φ Hex Cap Screws and Washers shall be ASTM F-593, alloy group 2 (316).
- ANCHOR BOLTS:** Anchor bolts shall be in accordance with ASTM A36 or ASTM F1554, Grade 36. Anchor Bolts, Nuts, and Washers shall be hot dip galvanized in accordance with Section 962 of the Specifications.
- RAIL END CAP:** ASTM B26 sand cast aluminum alloy 356.0-F.
- RAIL INSTALLATION:** Set Rail Posts normal to Profile Grade longitudinally and vertical transversely. Post spacings that land on barrier or parapet obstacles such as armor expansion plates etc. shall be adjusted to clear obstacles by 9" without exceeding maximum post spacing. Set Posts on 1/8" thick resilient or neoprene pads in accordance with Section 932 of the Specifications. The pad dimension shall be the same as the post base plate. Provide rail expansion joint in panels between posts on either side of Bridge Expansion Joints. Rail expansion joints shall be similar to rail splice with provision for movement equal to 1.5 times the bridge joint opening. Take care to ensure rails are set with the proper openings. Remove any burrs or sharp edges on rails and posts to prevent injury.
- RAIL SPLICES:** Rails shall be continuous over a minimum of 3 posts, except that lengths less than 12' need only be continuous over 2 posts. Space splices at 40'-0" maximum centers. Locate center of splice 1'-5" minimum from the edge of a post. Splice all rails in any railing section about the same center line.
- RESILIENT AND NEOPRENE PADS:** Resilient and Neoprene Pads shall be in accordance with the Specifications except that testing of the finished pads is not required. Neoprene pads shall be durometer hardness 60 or 70.
- SHOP DRAWINGS:** Submit complete details including rail, post and expansion joint locations and description of material of the proposed railing for the Engineer's approval prior to fabrication.
- CROSS REFERENCE:** For Post Details see Index No. 822, Sheet 1.

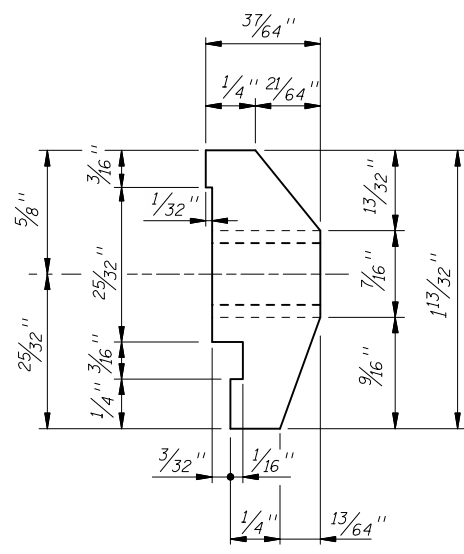

VIEW E-E

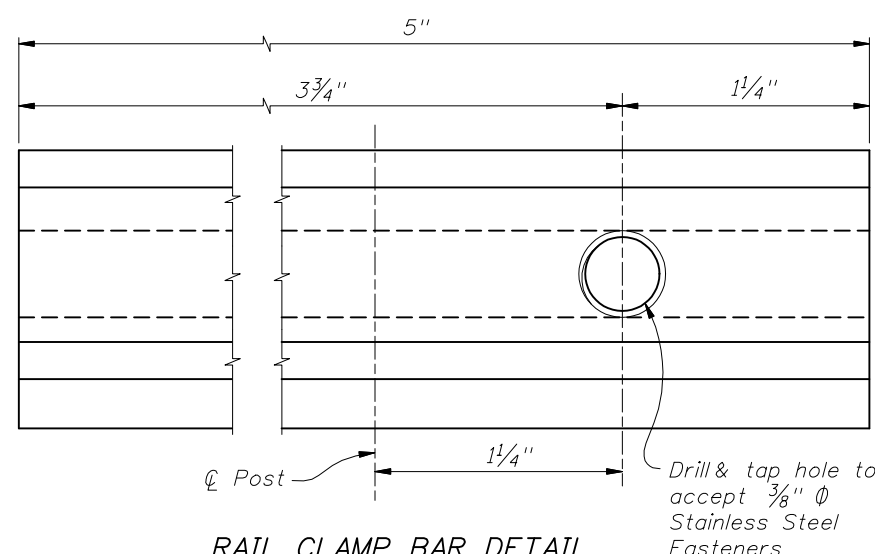

RAIL CLAMP BAR DETAIL

Drill & tap hole to accept 3/8" Φ Stainless Steel Fasteners

