

TYPICAL PANELS AND POSTS

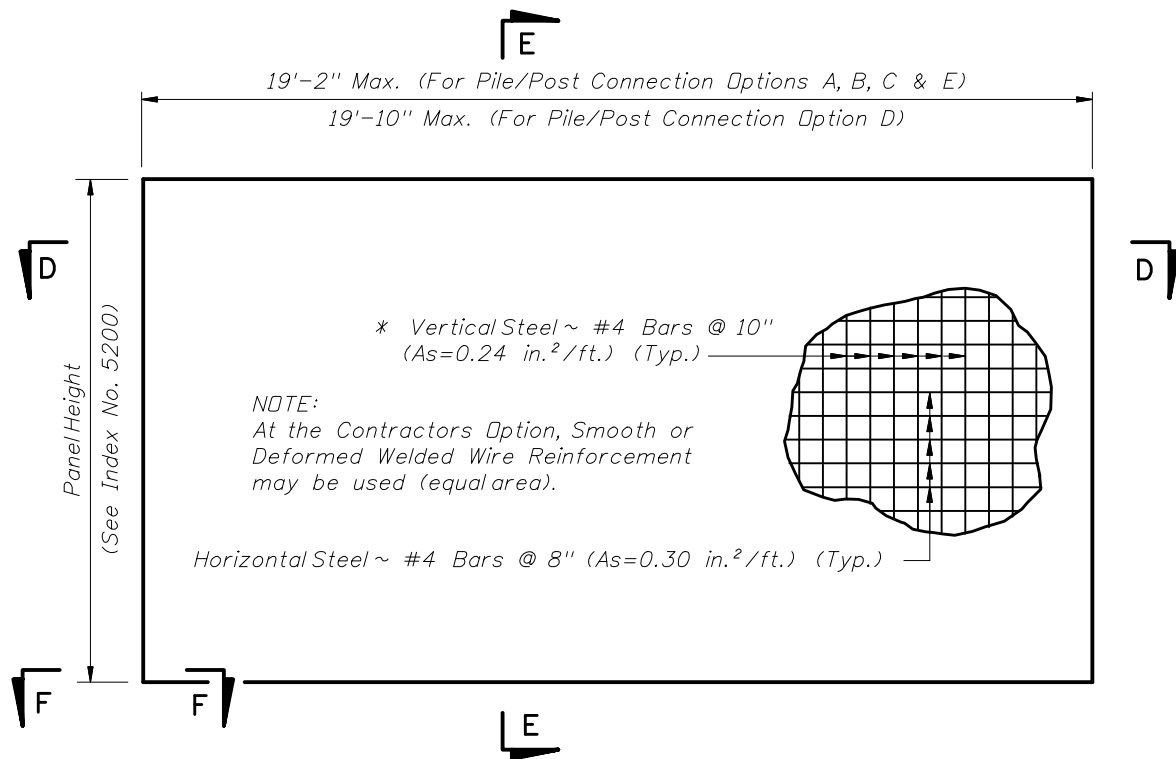

TYPICAL PANEL ELEVATION

\* In lieu of utilizing the pick up points below, panels may be cast vertically or cast horizontally then tilted upright using tilt-tables prior to lifting from form. In this case, the vertical steel may be reduced to #4 Bars @ 1'-3" (As=0.15 in.²/ft.).

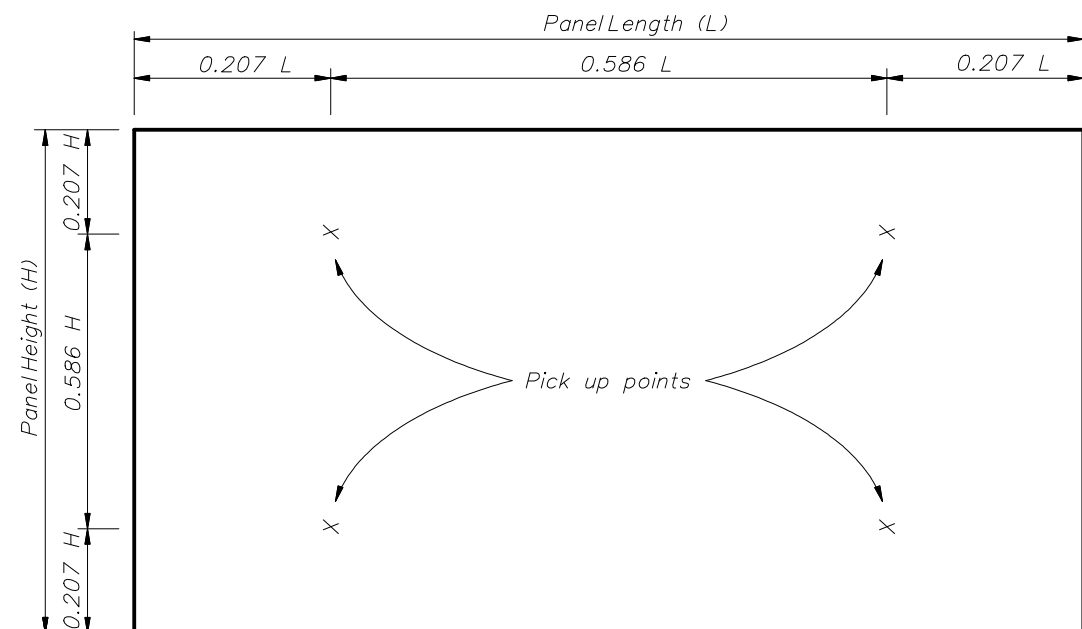

REQUIRED PICK UP POINTS FOR PANELS  
(Panels shall be rotated about long axis only)

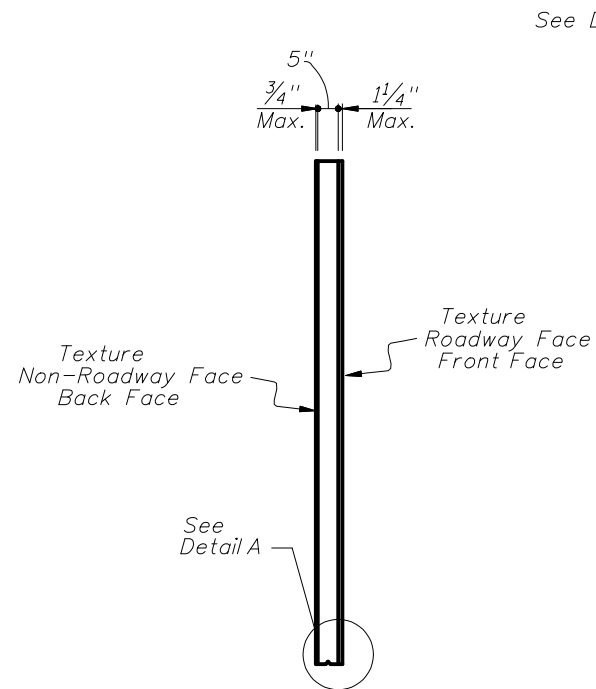

SECTION E-E

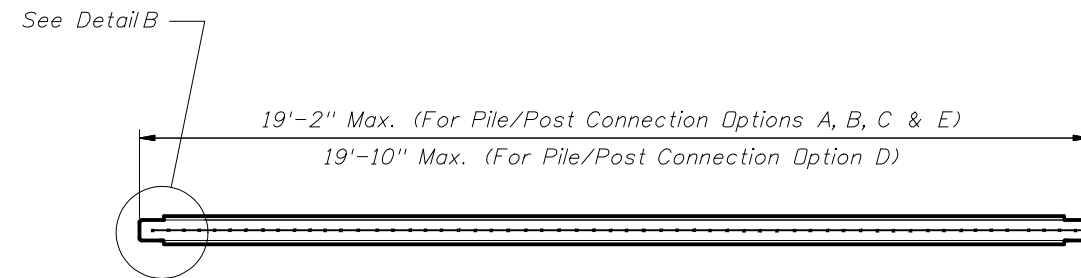

SECTION D-D

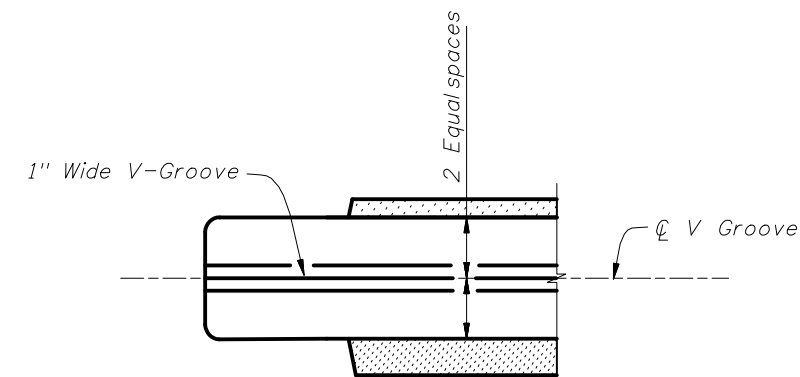

SECTION F-F

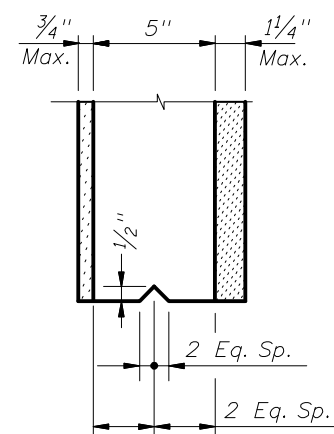

DETAIL A

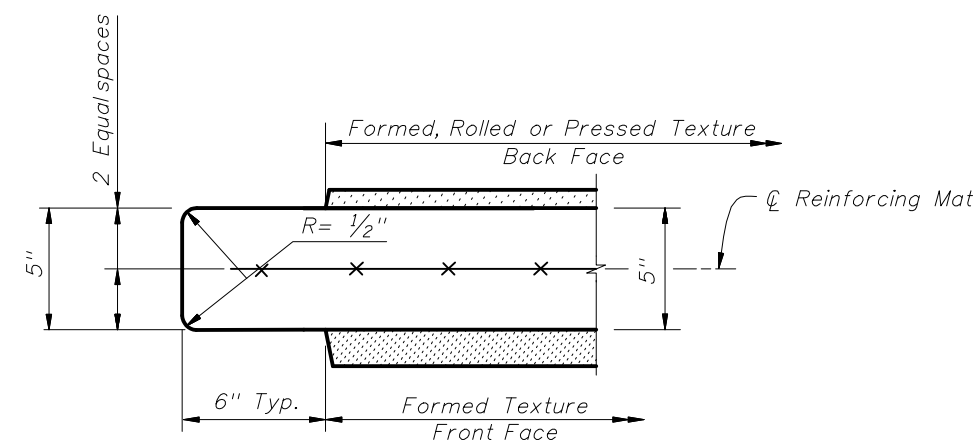

DETAIL B  
(Typical both ends)

TYPICAL PANELS AND POSTS



2010 FDOT Design Standards

PRECAST SOUND BARRIERS  
- RECESSED PANEL OPTION

Last Revision	Sheet No.
07/01/08	2 of 5
Index No.	
5203	



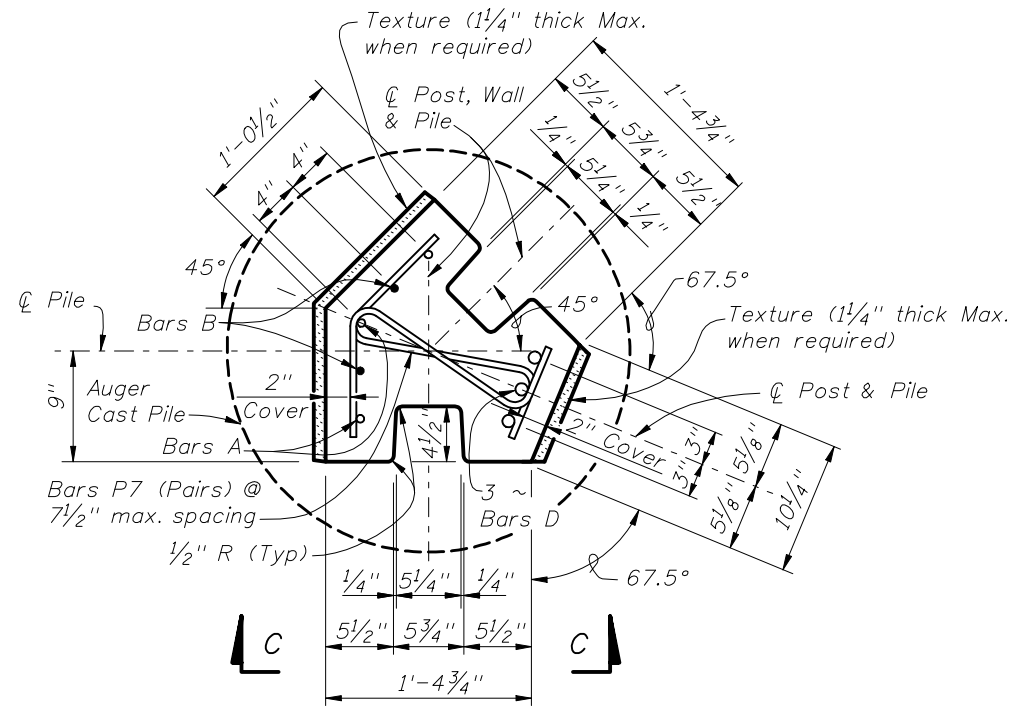

SECTION A-A  
TYPICAL SECTION ABOVE PILE

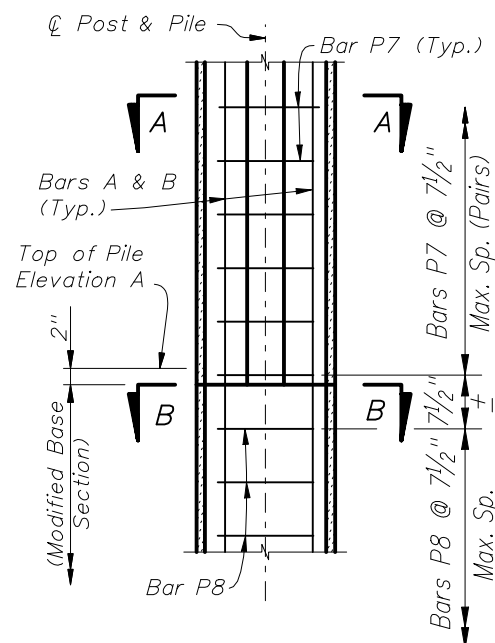

VIEW C-C (PARTIAL ELEVATION)  
(Only Front Faces Shown for Clarity)

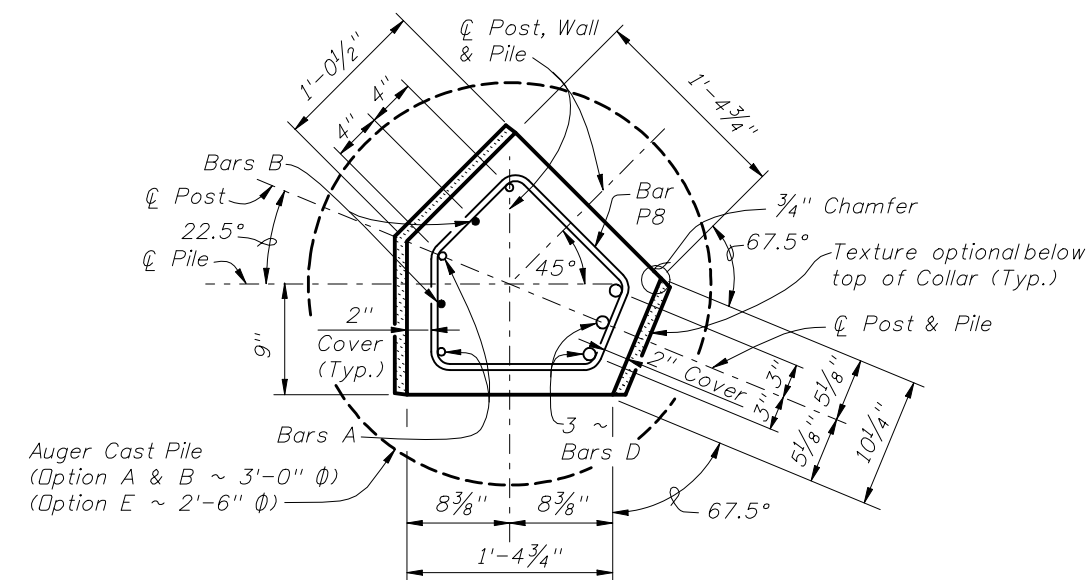

SECTION B-B  
PRECAST COLLAR SECTION

SPECIAL POSTS FOR 45° CORNERS FOR  
PILE/POST CONNECTION OPTIONS A, B & E

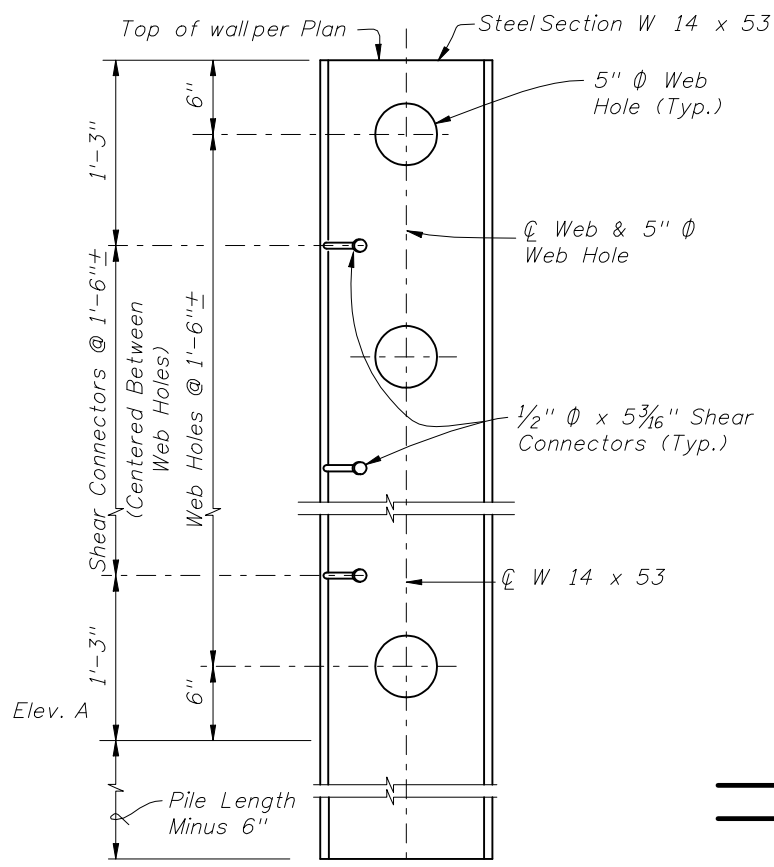

WEB HOLE AND SHEAR CONNECTOR  
SPACING DETAIL  
(Concrete not shown for clarity)

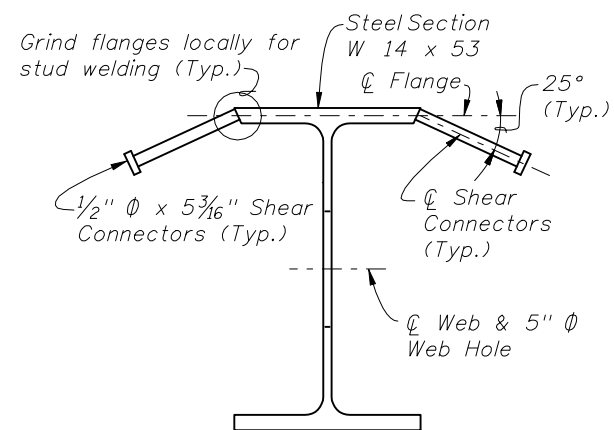

W 14 x 53 POST DETAIL

NOTE: The W 14 x 53 Section shall extend into the Auger Cast Pile.

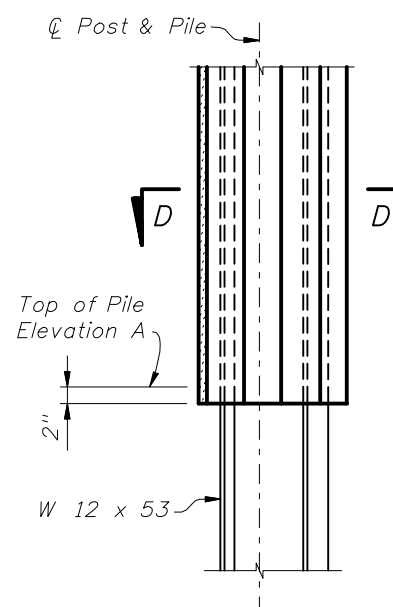

VIEW E-E (PARTIAL ELEVATION)  
(Only Front Faces Shown for Clarity)

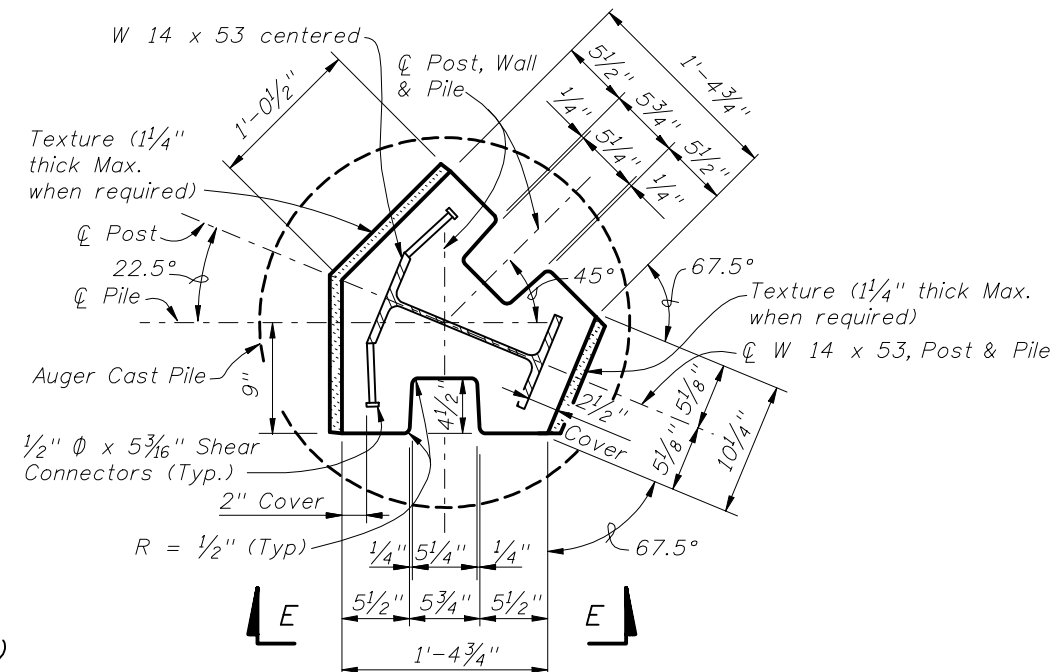

SECTION D-D  
TYPICAL SECTION ABOVE PILE

SPECIAL POSTS FOR 45° CORNERS FOR  
PILE/POST CONNECTION OPTIONS C & D

NOTES:

1. For Table of Reinforcing Steel Sizes, see Index No. 5206.
2. For Pile/Post Connection Options A through E, see Index No. 5205.
3. For Post & Pile Lengths, see Index No. 5206.
4. Shear Connectors shall be 5" long after welding.

SPECIAL 45° CORNER POSTS

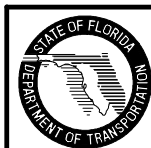

2010 FDOT Design Standards

PRECAST SOUND BARRIERS  
- RECESSED PANEL OPTION

Last Revision	Sheet No.
07/01/08	4 of 5
Index No.	
5203	

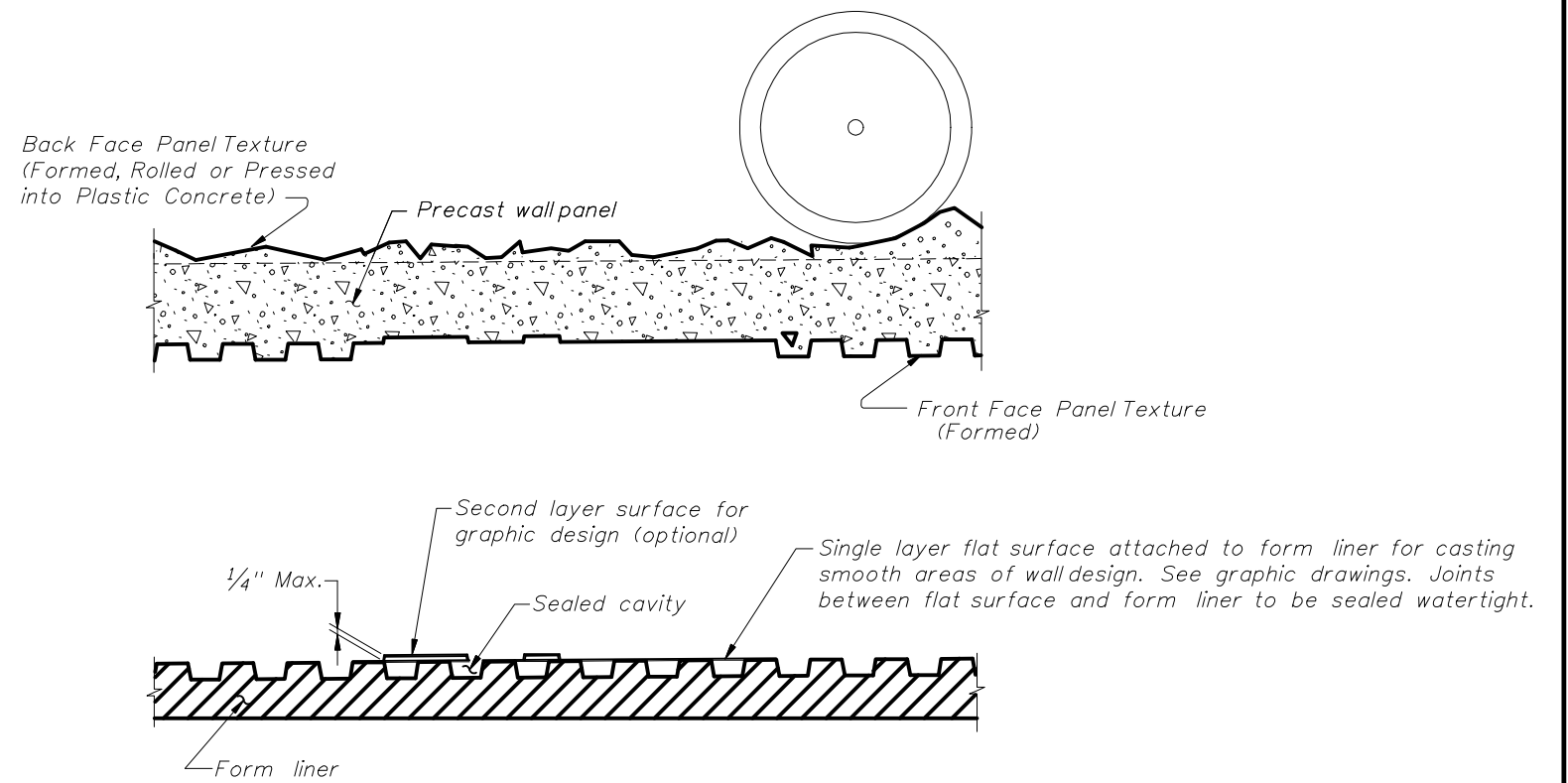
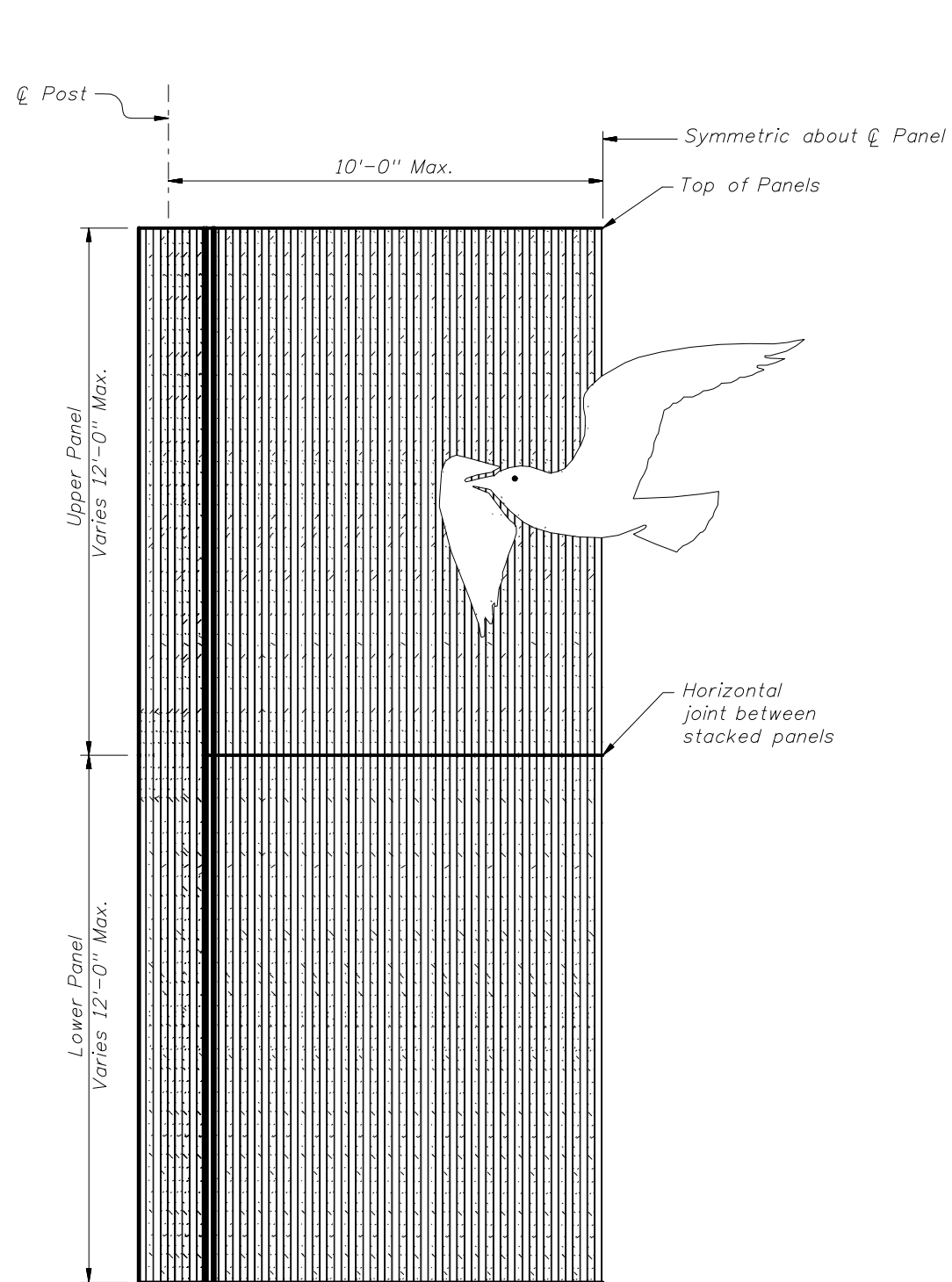

TYPICAL FORMING DETAIL  
 (Front Face Panel Texture Type "H" Shown.)  
 (Back Face Panel Texture Type "D" Shown.)

NOTES:

1. Contractor shall submit specific form liner samples for approval by the Engineer.
2. Textures and graphics shown are for demonstration purposes only. See Wall Control Drawings for project specific texture and graphic requirements.

HALF ELEVATION  
 (Pile/Post Connection Options A, B, C and E Shown.)  
 (Front Face Panel Texture Type "H" and Front Face Post Texture Type "H" Shown.)  
 (Graphic Type LG-3 Shown.)

