

VIEW A-A

(Shear key not shown)

NOTES

DESIGN SPECIFICATIONS:

Design according to FDOT Structures Manual (current edition).

MATERIALS:

All reinforcing steel shall conform to ASTM A615 Grade 60.

SURFACE FINISH:

A Class 5 Applied Finish Coating shall be applied to the top of the wall and the exposed face above ground line.

ARCHITECTURAL TREATMENT:

Alternate Architectural Treatments may be substituted for the Striated Pattern shown when approved by the Engineer. Concrete required for Architectural Treatment is not included in the quantities.

TRAFFIC RAILING BARRIER:

If there is a Traffic Railing Barrier on the wall, Wall Joints and Barrier V-Grooves shall align and Wall Expansion Joints and Barrier Open Joints shall align.

FOUNDATION: Prepare the soil below the footing in accordance with the requirements for spread footings in Specification Section 455.

PAYMENT:

All Retaining Wall costs, including all miscellaneous costs, shall be paid for at the unit contract price for either Class II, III or IV Concrete (Retaining Walls) (CY) and Reinforcing Steel (Retaining Walls) (LBS). Retaining Wall quantities shall not include concrete nor reinf. steel for Traffic Railings. Traffic Railing (including Bars 5V) shall be paid for under Concrete Traffic Railing (Bridge).

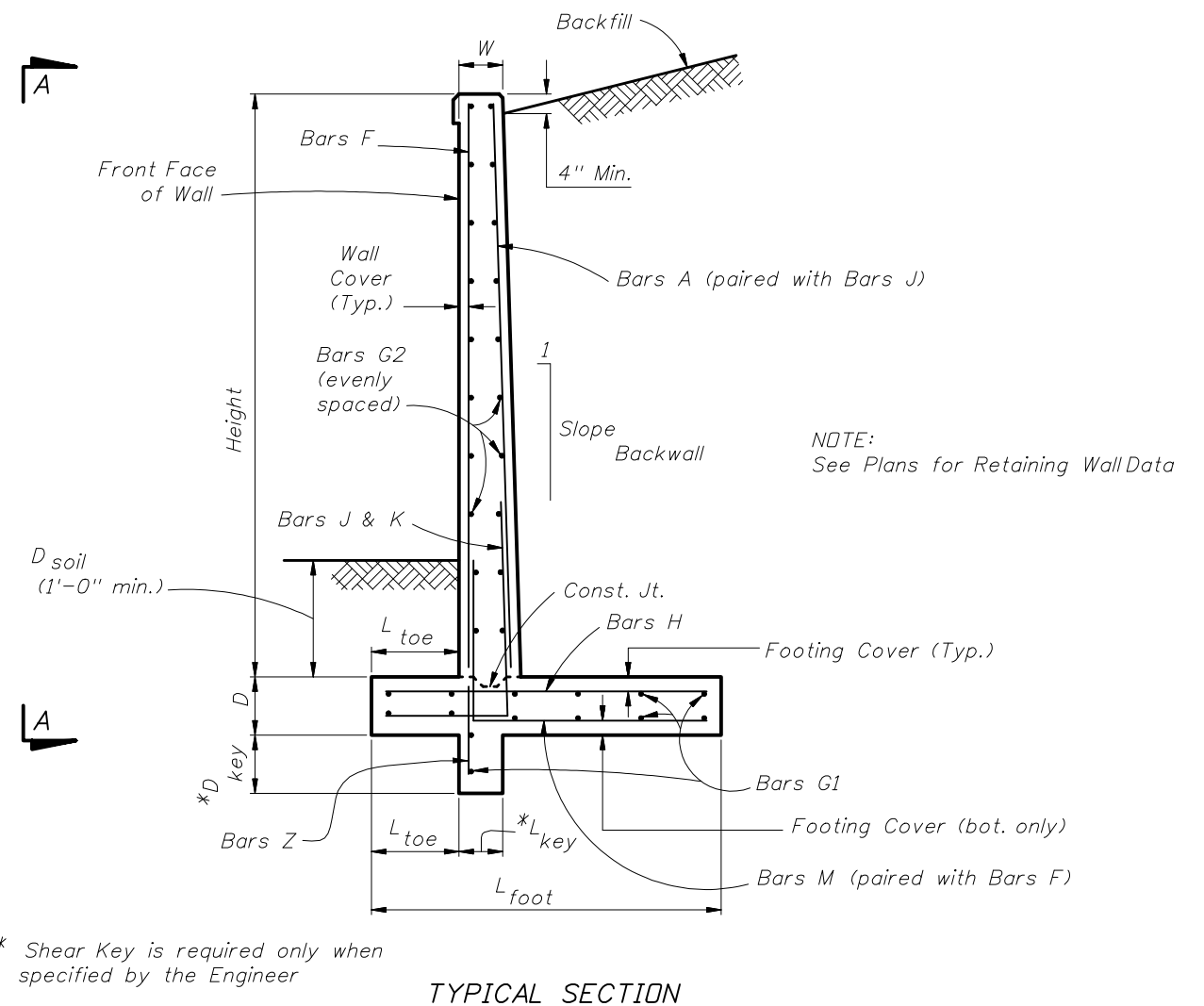

NOTE:
See Plans for Retaining Wall Data

TYPICAL SECTION

* Shear Key is required only when specified by the Engineer

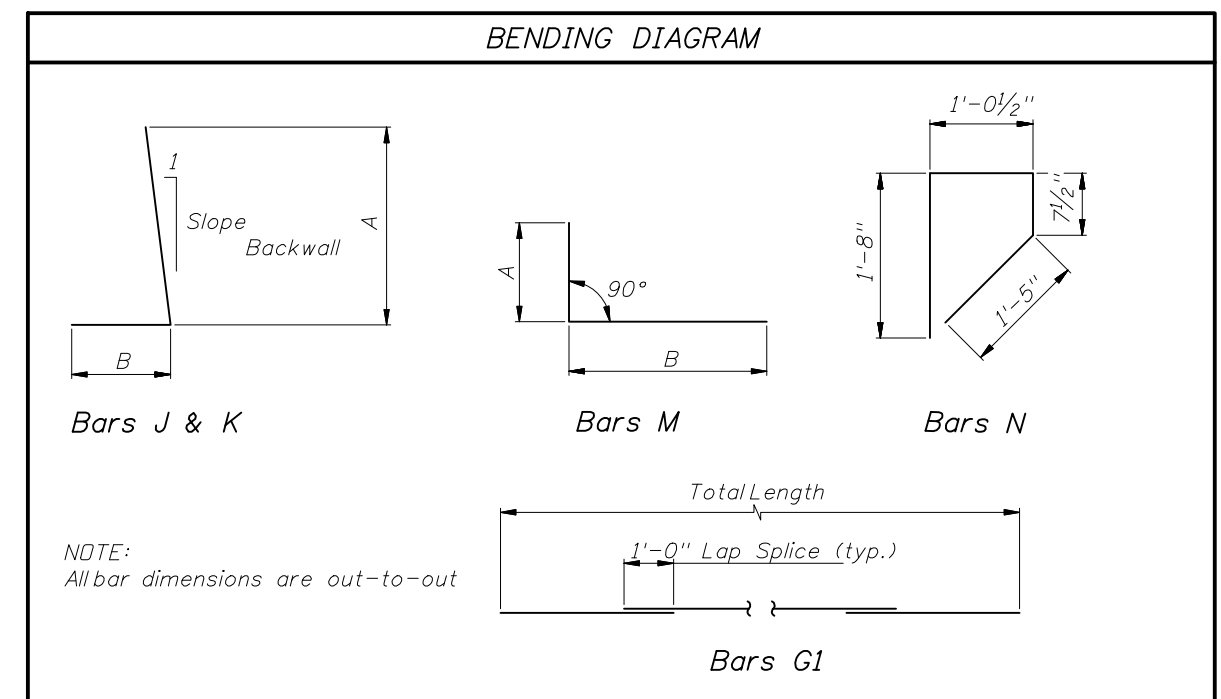

NOTE:
All bar dimensions are out-to-out



2010 FDOT Design Standards

RETAINING WALL - CAST IN PLACE

Last Revision	Sheet No.
01/01/08	1 of 2
Index No.	
5100	

