

SECTION AA
INLET LENGTHS (L) LESS THAN OR EQUAL TO 9' (SINGLE LAYER WALL REINFORCING)

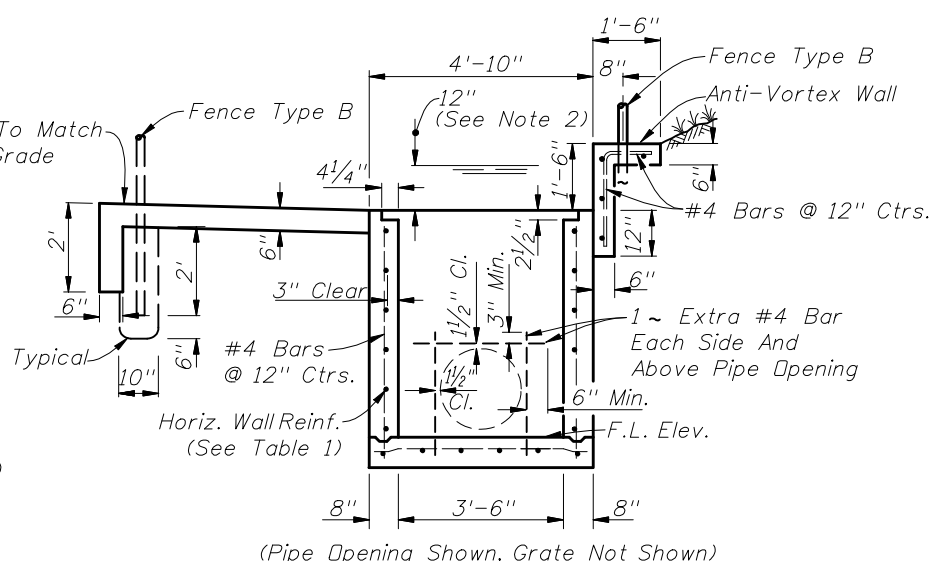

SECTION BB
(Pipe Opening Shown, Grate Not Shown)

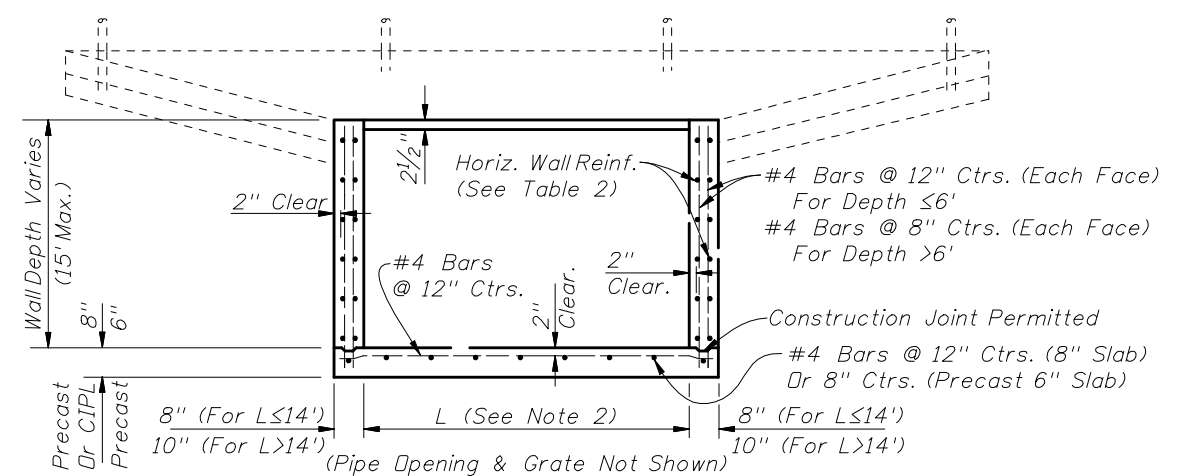

SECTION AA
INLET LENGTHS (L) GREATER THAN OR EQUAL TO 9' (DOUBLE LAYER WALL REINFORCING)

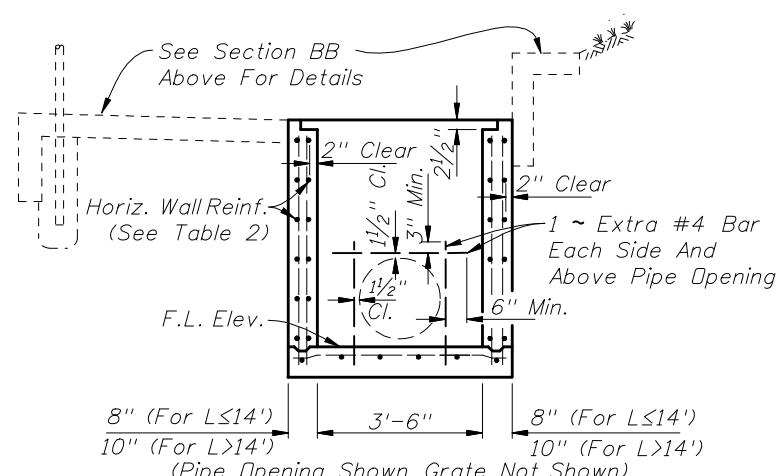

SECTION BB
(Pipe Opening Shown, Grate Not Shown)

GENERAL NOTES

1. This inlet is to be used at locations having high flow rates, usually where an endwall could not be utilized without hazardous intake.
2. Inlet length (L) shall be set by the designer for the greater of either culvert requirement or inlet pool not to exceed 12' depth. Structures over 6 feet in depth are to be checked for flotation by the designer of project drainage.
3. This inlet is not intended for use with Index 200 structure bottoms.
4. All exposed edges and corners shall be 3/4" chamfer or tooled to 1/4" radius.
5. Inlet and anti-vortex wall to be Class II Concrete.
6. All reinforcing is Grade 60 with 2" min. cover unless otherwise noted. See Index No. 201 for equivalent area of welded wire fabric (WWF). Bars to be cut or bent for 1/2" clearance around pipe opening. Bend top and corner bars to clear anchor holes.
7. Channel section C 3x6 at 14" max. bar spacing may be used as an alternate for the C 4x5.4 channel at 15" bar spacing.
8. Channels and bars for grate shall be ASTM A242/A242M, A572/A572M or A588/A588M, Grade 50 steel, and galvanized in accordance with Specification Section 975.
9. Fence enclosure shall be Fence Type B (Index No. 802). All posts to be set in concrete. A minimum of 10 posts required. Corner and approach side posts to be 3" nominal diameter.
10. Cost of ditch paving, anti-vortex wall, grate, concrete, reinforcing steel and fence enclosure to be included in the cost of inlet. Inlet to be paid for under the contract unit price for Inlets (DT Bot) (Type K), Each.
11. Anchor Bolts shall be ASTM F1554 Grade 36 fully threaded headless bolts, installed in accordance with Specification Sections 416 and 937. Nuts shall be ASTM A563 or A194 and washers shall be ASTM F436 or Type A plain washers. All nuts, bolts and washers shall be galvanized.



2010 FDOT Design Standards

**DITCH BOTTOM INLET
TYPE K**

Last Revision	Sheet No.
07/01/09	1 of 2
Index No.	
235	

HORIZONTAL WALL REINFORCING SCHEDULES

WALL DEPTH	SCH.	AREA (in. ² /ft.)	MAX. SPACING BARS	WMF
SIZE: L=5'-0"				
0'-5'	A12	0.20	12"	8"
5'-8'	A6	0.20	6"	5"
8'-15'	B5.5	0.24	5½"	5"
SIZE: L=6'-0"				
0'-4'	A12	0.20	12"	8"
4'-6'	B5.5	0.24	5½"	5"
6'-9'	C6.5	0.37	6½"	6"
9'-15'	C3.5	0.37	3½"	3"
SIZE: L=7'-0"				
0'-4'	B5.5	0.24	5½"	5"
4'-7'	C6.5	0.37	6½"	6"
7'-15'	D4.5	0.53	4½"	4"
SIZE: L=8'-0"				
0'-3'	B5.5	0.24	5½"	5"
3'-5'	C6.5	0.37	6½"	6"
5'-9'	D4.5	0.53	4½"	4"
9'-15'	E5	0.73	5"	4"
SIZE: L=9'-0"				
0'-4'	C6.5	0.37	6½"	6"
4'-7'	D4.5	0.53	4½"	4"
7'-15'	E3	0.73	3"	3"

WALL DEPTH	SCH.	AREA (in. ² /ft.)	MAX. SPACING BARS	WMF
SIZE: L=9'-0"				
0'-4'	A12	0.20	12"	8"
4'-6'	A6	0.20	6"	5"
6'-8'	B5.5	0.24	5½"	5"
8'-15'	C6.5	0.37	6½"	6"
SIZE: L=10'-0"				
0'-3'	A12	0.20	12"	8"
3'-5'	A6	0.20	6"	5"
5'-8'	C6.5	0.37	6½"	6"
8'-15'	C3.5	0.37	3½"	3"
SIZE: L=12'-0"				
0'-4'	B5.5	0.24	5½"	5"
4'-6'	C6.5	0.37	6½"	6"
6'-15'	D4.5	0.53	4½"	4"
SIZE: L=14'-0"				
0'-4'	C6.5	0.37	6½"	6"
4'-7'	D4.5	0.53	4½"	4"
7'-15'	E5	0.73	5"	4"
SIZE: L=16'-0" x 10" WALL THICK				
0'-4'	C6.5	0.37	6½"	6"
4'-8'	D4.5	0.53	4½"	4"
8'-15'	E5	0.73	5"	4"
SIZE: L=18'-0" x 10" WALL THICK				
0'-3'	C6.5	0.37	6½"	6"
3'-5'	D4.5	0.53	4½"	4"
5'-8'	E5	0.73	5"	4"
8'-15'	F5	1.06	5"	4"

SINGLE LAYER REINFORCING (TABLE 1)

DOUBLE LAYER REINFORCING (TABLE 2)

GRATE QUANTITIES

PIPE SIZE	L	S	BILL OF STEEL			STEEL WEIGHT		
			BAR	No. REQD.	LENGTH	CHANNEL 4"x 5.4#	ANGLE 3"x 2½"x ¼" (4.5#/FT.)	FLAT 2" x ½" (3.4#/FT.)
30" & 36"	5'-0"	12¾"	A	5	4'-1½"	111	45	51
			B	2	4'-11½"			
			C	3	4'-11½"			
42" & 48"	6'-0"	11¼"	A	6	4'-1½"	134	54	61
			B	2	5'-11½"			
			C	3	5'-11½"			
54" & 60"	7'-0"	9¾"	A	7	4'-1½"	156	63	71
			B	2	6'-11½"			
			C	3	6'-11½"			
66" & 72"	8'-0"	8¼"	A	8	4'-1½"	178	72	81
			B	2	7'-11½"			
			C	3	7'-11½"			
84"	9'-0"	14¼"	A	8	4'-1½"	178	81	91
			B	2	8'-11½"			
			C	3	8'-11½"			
SPECIAL	10'-0"	12¾"	A	9	4'-1½"	201	90	102
			B	2	9'-11½"			
			C	3	9'-11½"			
SPECIAL	12'-0"	9¾"	A	11	4'-1½"	245	108	122
			B	2	11'-11½"			
			C	3	11'-11½"			
SPECIAL	14'-0"	14¼"	A	12	4'-1½"	267	126	142
			B	2	13'-11½"			
			C	3	13'-11½"			
SPECIAL	16'-0"	11¼"	A	14	4'-1½"	312	144	163
			B	2	15'-11½"			
			C	3	15'-11½"			
SPECIAL	18'-0"	8¼"	A	16	4'-1½"	356	162	183
			B	2	17'-11½"			
			C	3	17'-11½"			

Table Notes:
See Sheet No. 1 of 2 for dimension "L" location.
See steel grate Plan View for dimension "S" location.

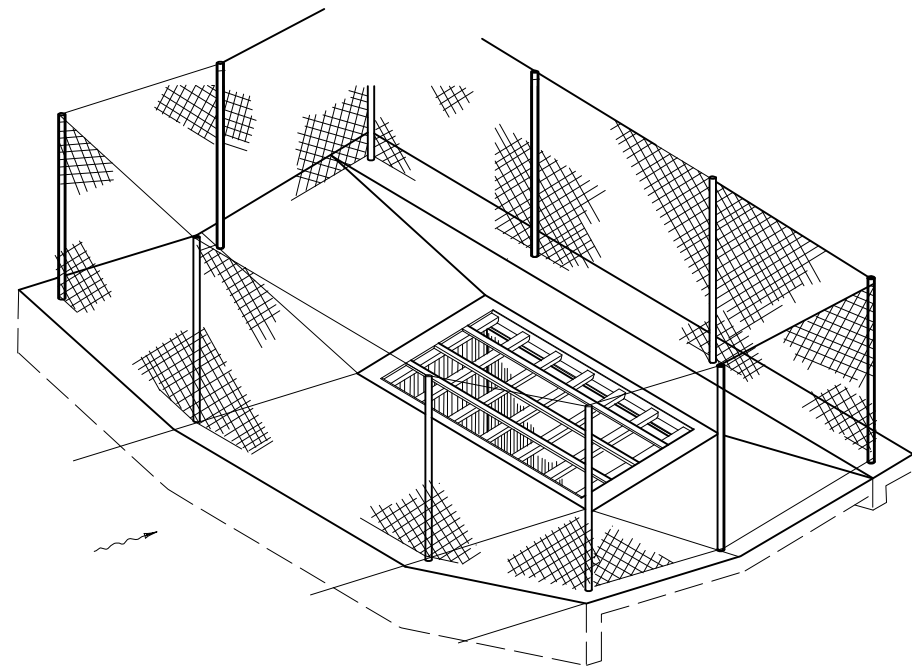

ISOMETRIC OF INLET FENCE ENCLOSURE

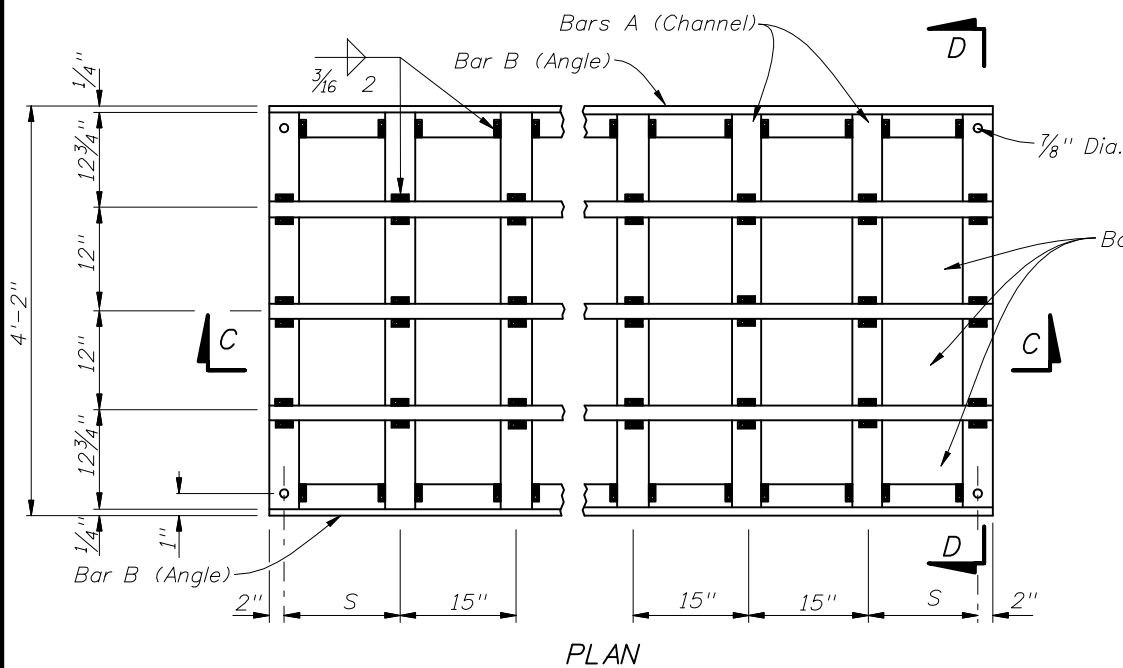

PLAN

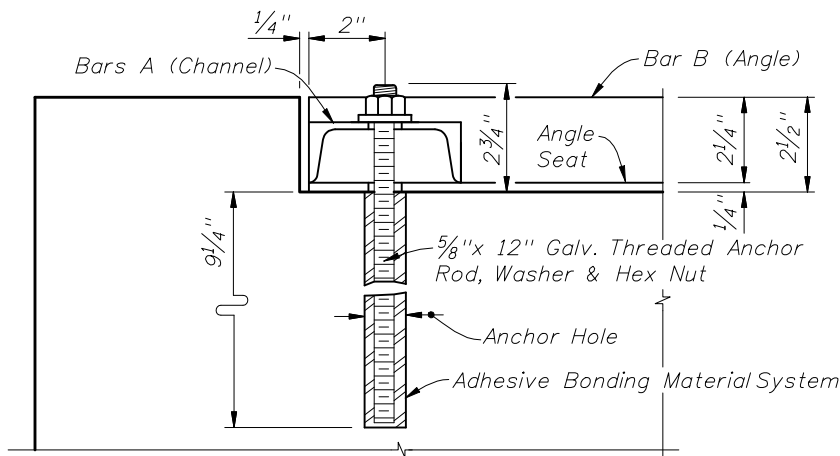

SECTION FF

STEEL GRATE

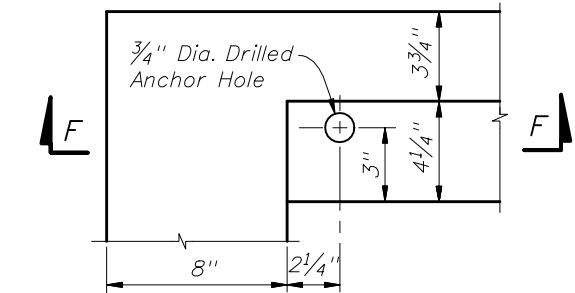

GRATE SEAT AND ANCHOR HOLE PLAN

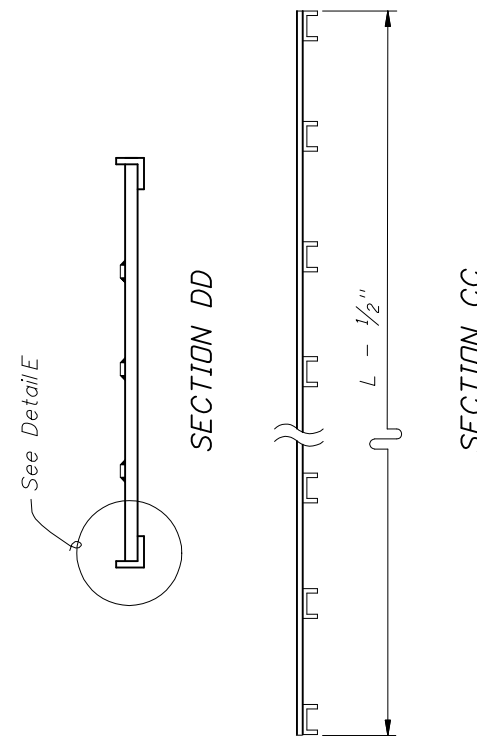

SECTION DD

SECTION CC

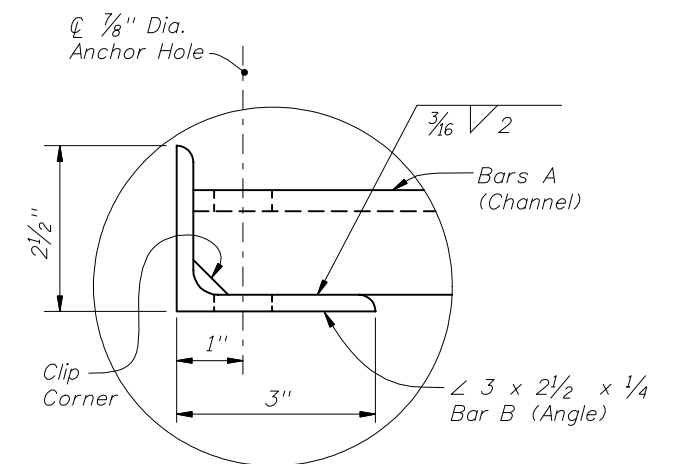

DETAIL E

