

**CROSS REFERENCES:**

For Sections A-A and B-B see Sheet 2.

For View F-F see Sheet 3.

**NOTE:**

Plastic Lumber and Composite Lumber Dimensions shown are based on Nominal Lumber Dimensions and may vary depending on Actual Lumber Dimension.

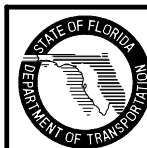
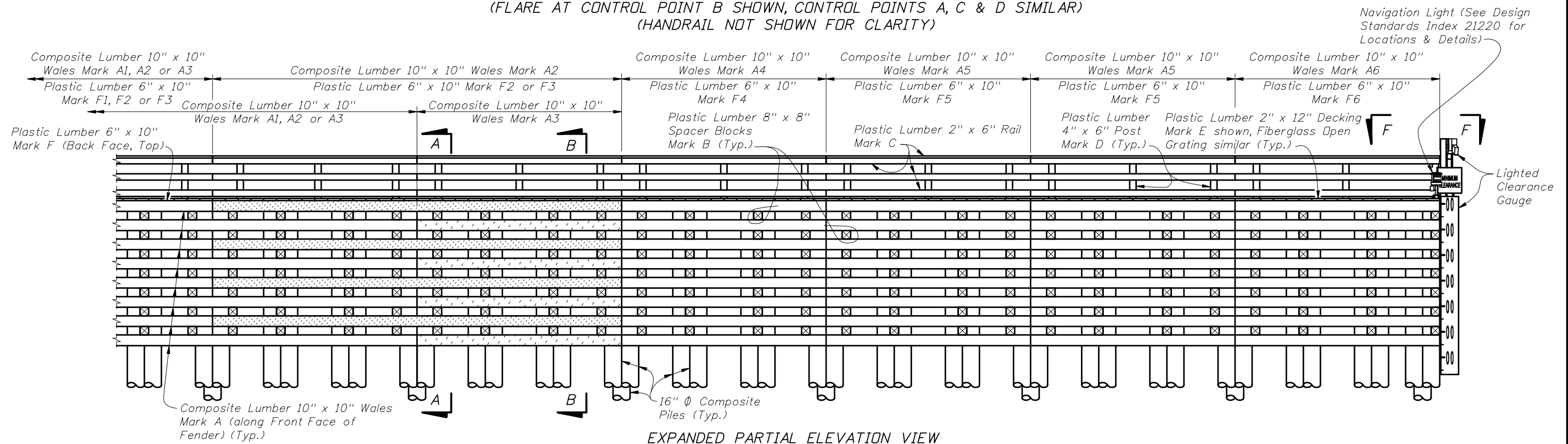
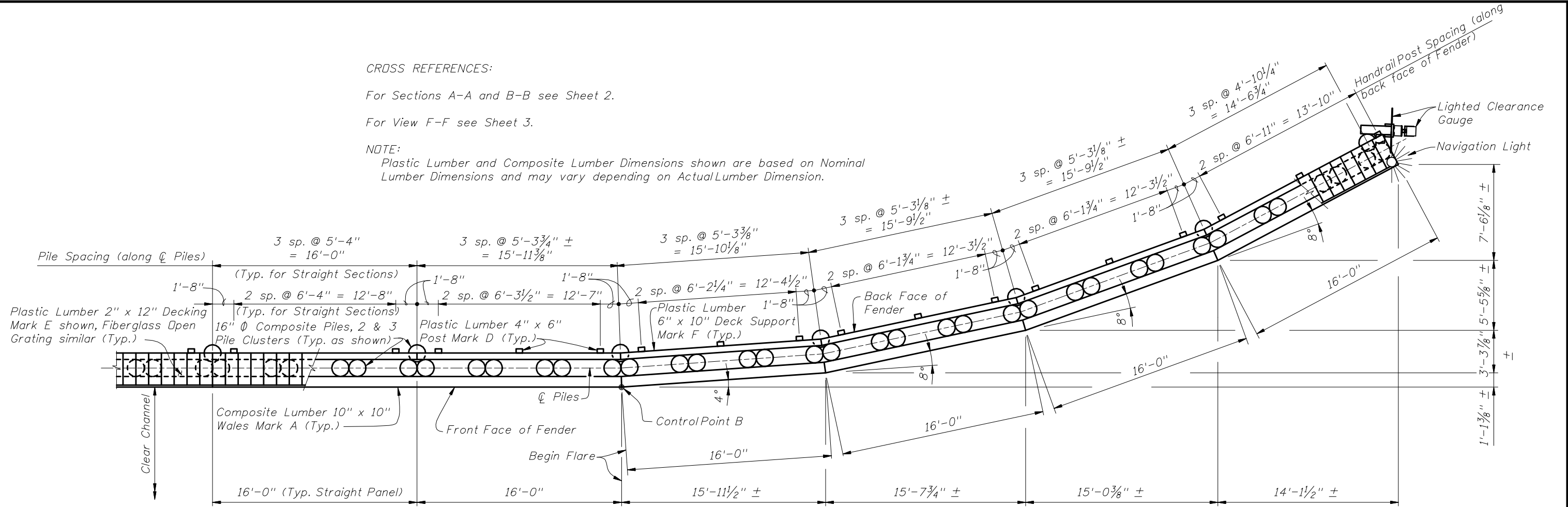

2010 FDOT Design Standards

**FENDER SYSTEM - HEAVY DUTY**

Last Revision	Sheet No.
01/01/06	1 of 5
Index No.	
21910	



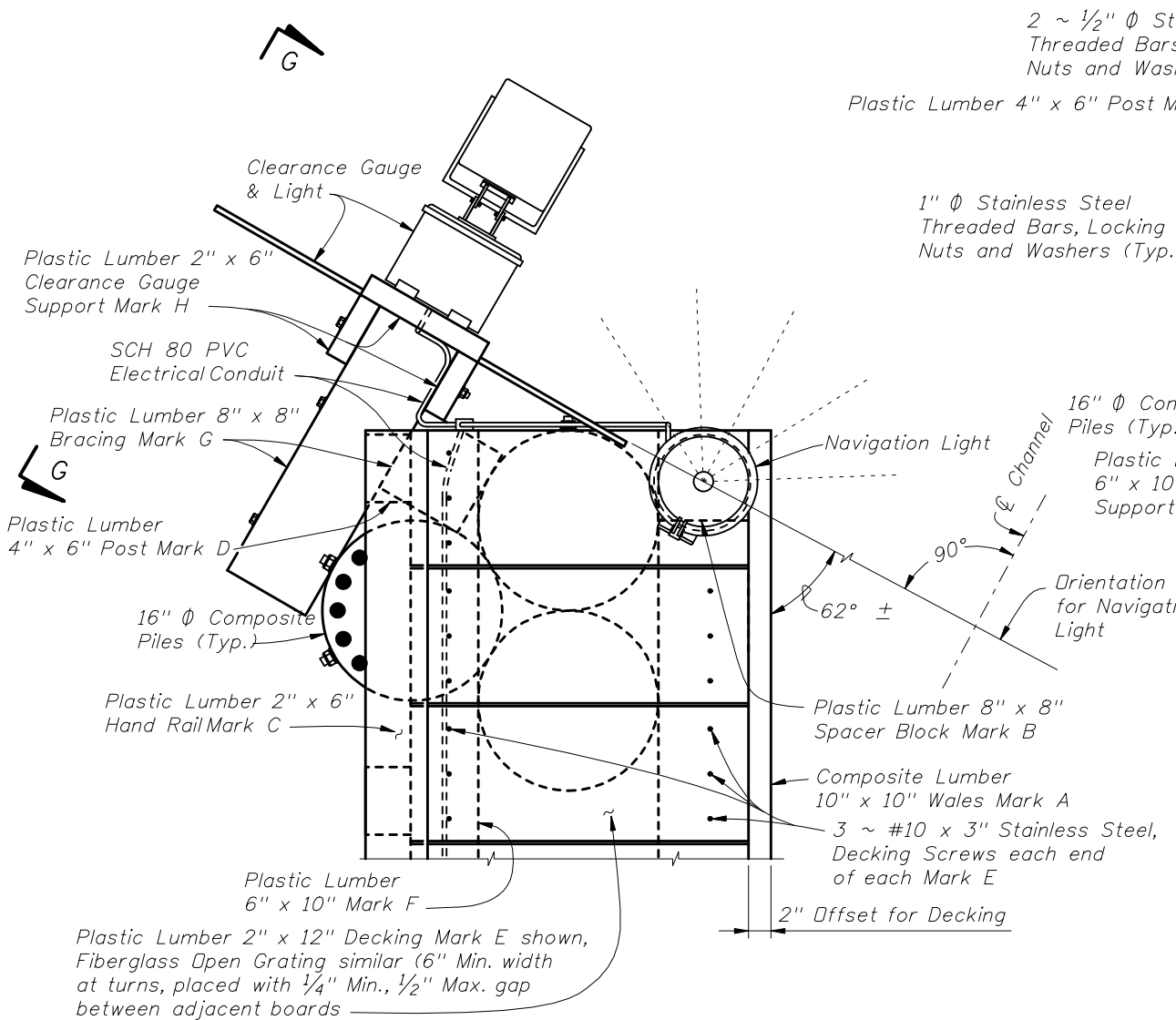

VIEW F-F  
(SHOWING FENDER END WITH CLEARANCE GAUGE;  
FENDER END WITHOUT CLEARANCE GAUGE SIMILAR)

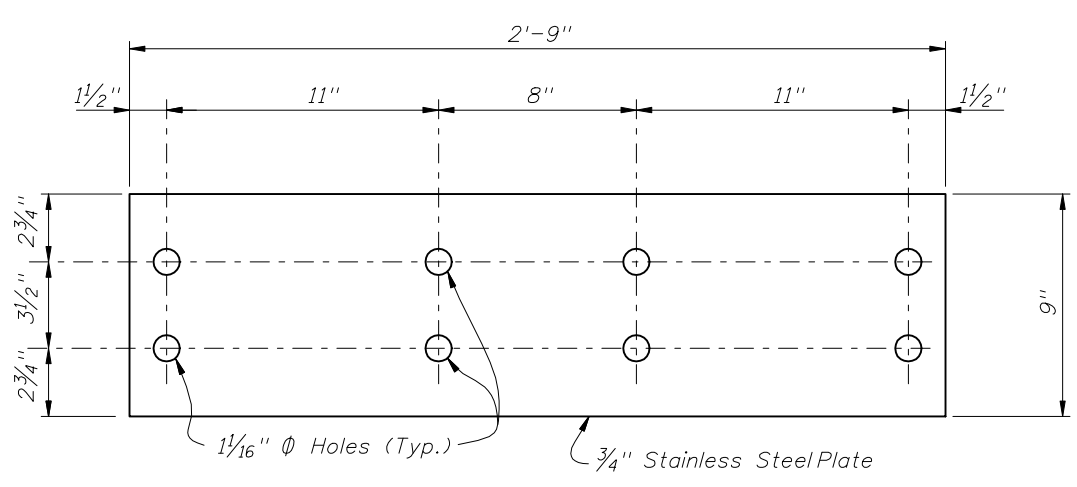

SPLICE PLATE DETAIL

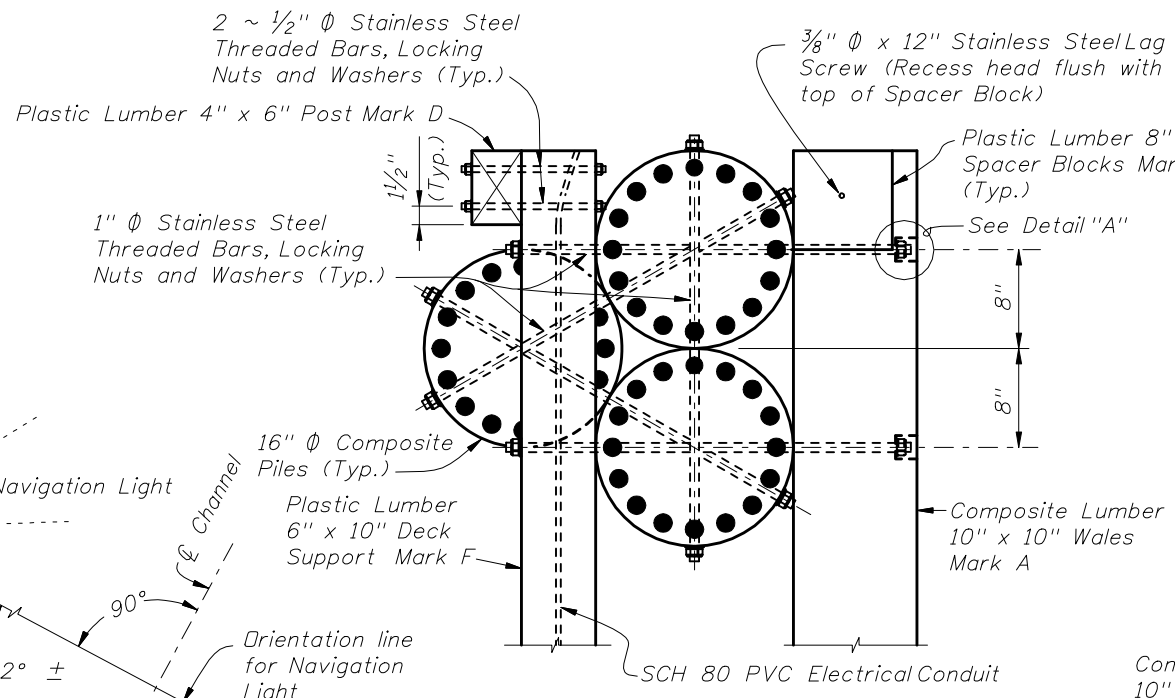

VIEW F-F  
(SHOWING FENDER END; DECKING,  
HANDRAIL AND CLEARANCE GAUGE  
NOT SHOWN FOR CLARITY)

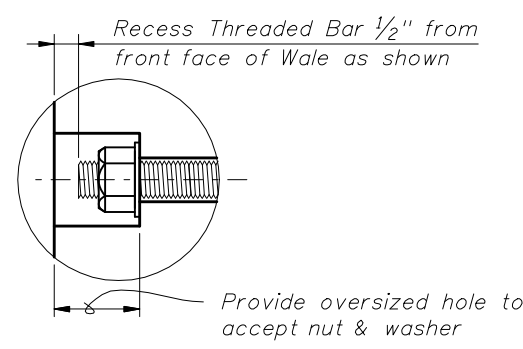

DETAIL "A"

CROSS REFERENCES:

For Navigation Lights and SCH 80 PVC Electrical Conduit Details see Design Standard Index 21220.

For Clearance Gauge Details and View G-G see Sheet 4.

For location of View F-F see Sheet 1.

For location of Section E-E see Sheet 2.

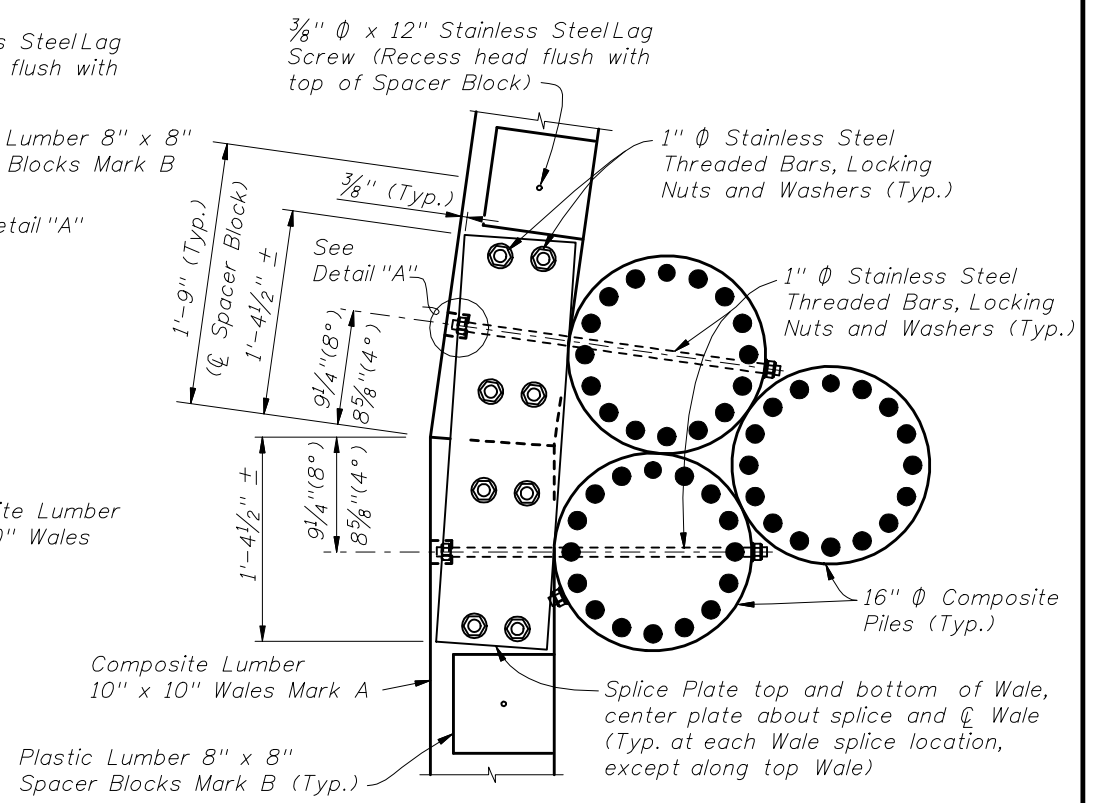

SECTION E-E  
TYPICAL FLARED SECTION  
(8° TURN SHOWN, 4° TURN SIMILAR)

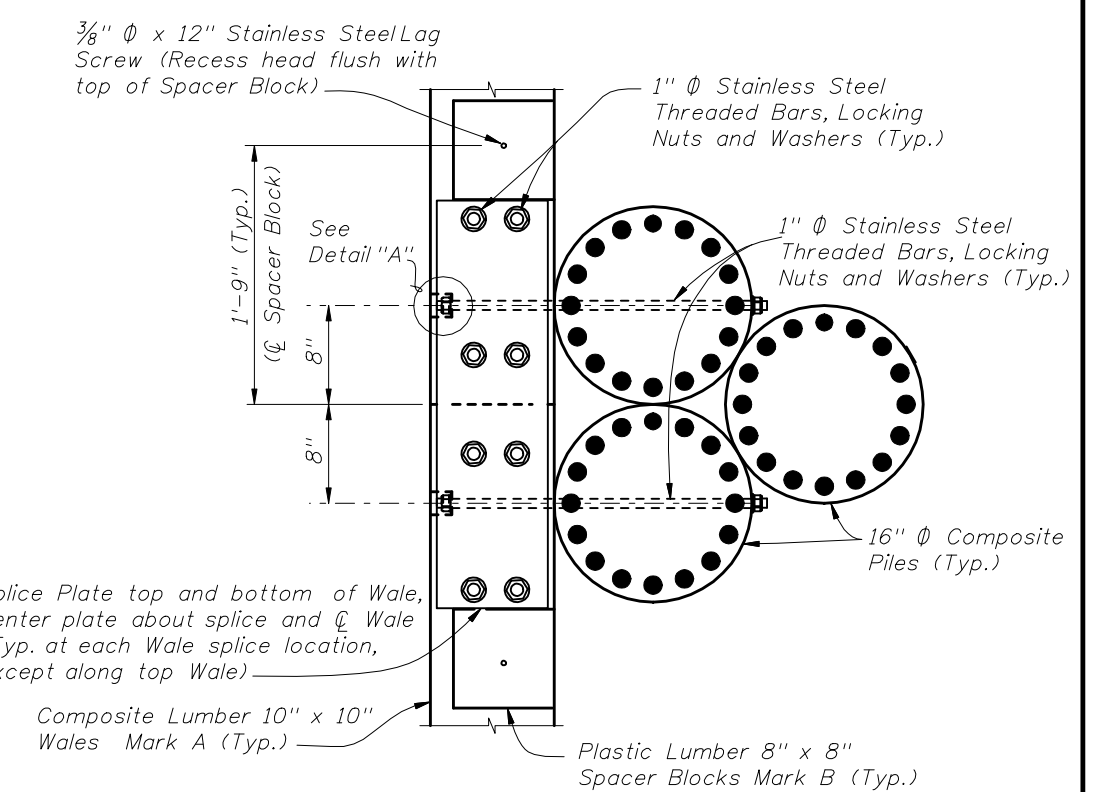

SECTION E-E  
TYPICAL STRAIGHT SECTION

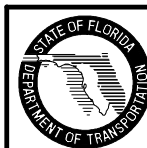

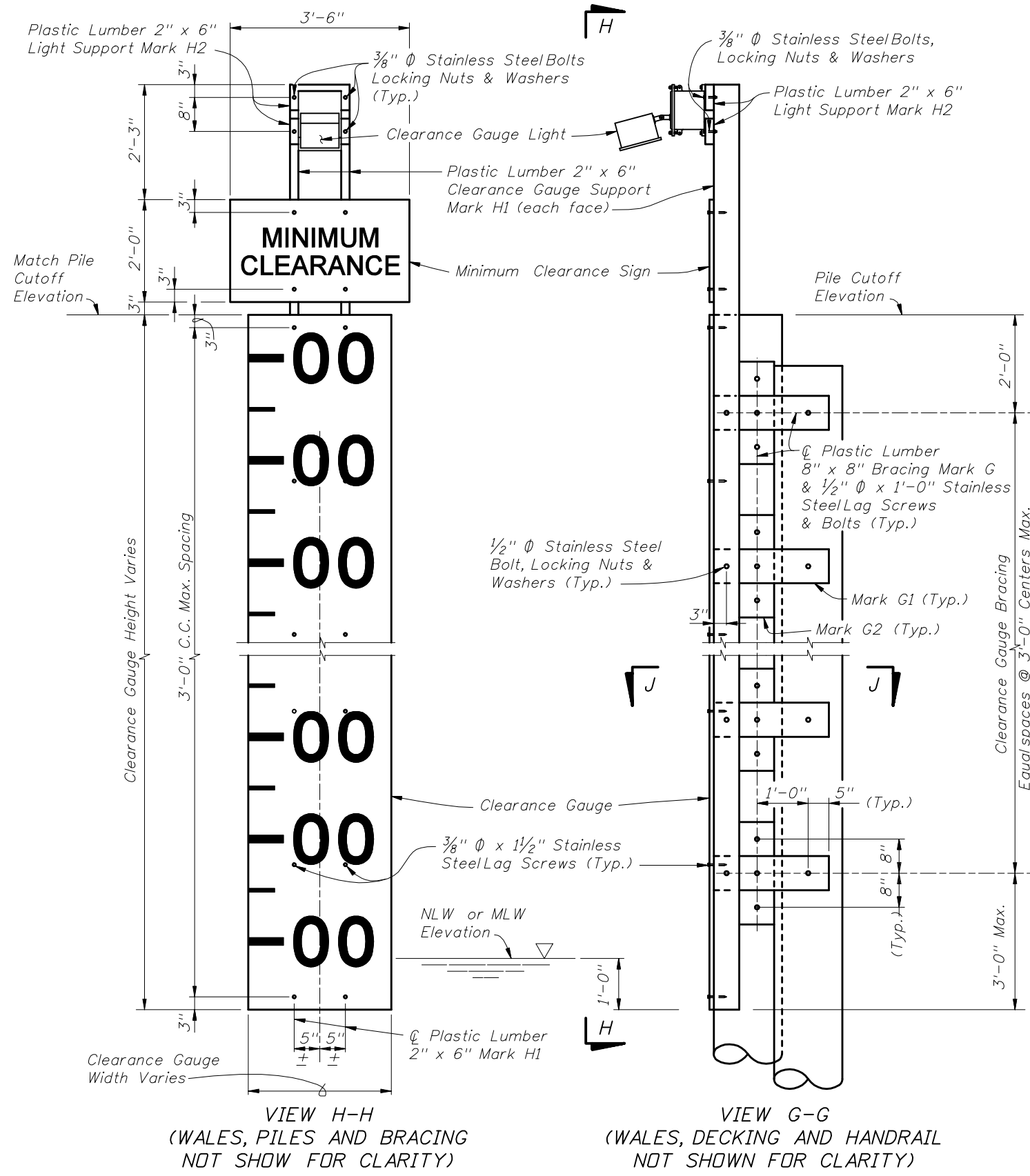

**CLEARANCE GAUGE DETAILS**

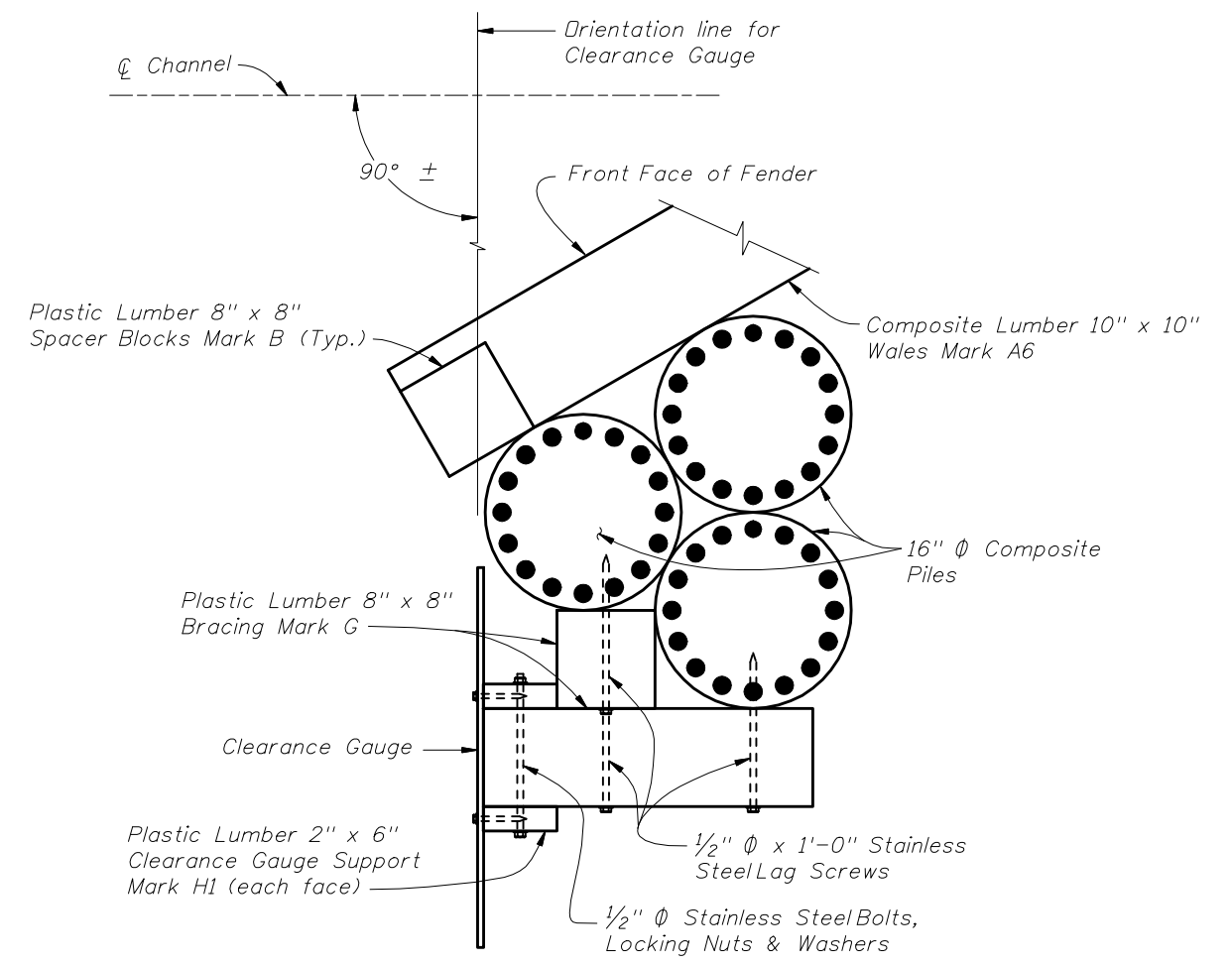

**SECTION J-J**

CROSS REFERENCES:  
 For Structural Composite and Plastic Lumber Bill of Materials Quantities and Fender System Table of Variables see Structures Plans.  
 For location of View G-G see Sheet 3.

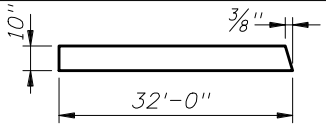
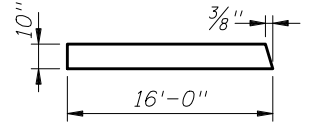
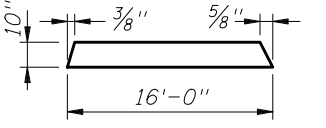
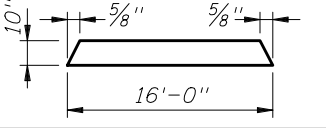
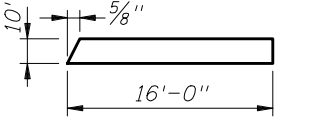

* STRUCTURAL COMPOSITE LUMBER BILL OF MATERIALS					
MARK	SIZE (NOMINAL)	DIMENSIONS	BOARD FT. PER EACH	NO. REQD.	QUANTITY
A1	10" X 10" COMPOSITE LUMBER	32'-0" (STRAIGHT)	266.6	See Estimated Structural Composite and Plastic Lumber Bill of Materials Table in Structures Plans	
A2	10" X 10" COMPOSITE LUMBER		266.6		
A3	10" X 10" COMPOSITE LUMBER		133.3		
A4	10" X 10" COMPOSITE LUMBER		133.3		
A5	10" X 10" COMPOSITE LUMBER		133.3		
A6	10" X 10" COMPOSITE LUMBER		133.3		

\* All Plastic Lumber and Composite Lumber Dimensions and Quantities shown are based on Nominal Lumber Dimensions and may vary depending on Actual Lumber Dimension.

\*\* Provide Fiberglass Open Grating in lieu of 2" X 12" Plastic Lumber when called for in the Plans. Mounting hardware shall be Stainless Steel, install per Manufacturer's recommendations. See Index No. 21900 and Structures Plans for Notes and Details.

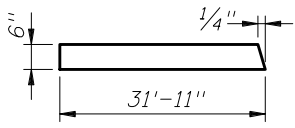
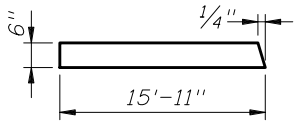
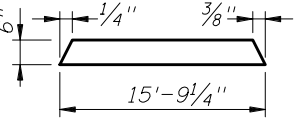
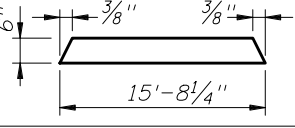
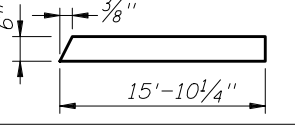
* PLASTIC LUMBER BILL OF MATERIALS					
MARK	SIZE (NOMINAL)	DIMENSIONS	BOARD FT. PER EACH	NO. REQD.	QUANTITY
B	8" X 8" PLASTIC LUMBER	8" (STRAIGHT)	3.6	See Estimated Structural Composite and Plastic Lumber Bill of Materials Table in Structures Plans	
C	2" X 6" PLASTIC LUMBER	16'-0" (STRAIGHT) (Trim & Miter Ends as required)	16.0		
D	4" X 6" PLASTIC LUMBER	4'-4" (STRAIGHT)	8.7		
** E	2" X 12" PLASTIC LUMBER	2'-6" (STRAIGHT) (Miter as required)	5.0		
F1	6" X 10" PLASTIC LUMBER	32'-0" (STRAIGHT)	160.0		
F2	6" X 10" PLASTIC LUMBER		159.6		
F3	6" X 10" PLASTIC LUMBER		79.6		
F4	6" X 10" PLASTIC LUMBER		78.8		
F5	6" X 10" PLASTIC LUMBER		78.4		
F6	6" X 10" PLASTIC LUMBER		79.2		
G1	8" X 8" PLASTIC LUMBER	2'-3" (STRAIGHT)	12.0		
G2	8" X 8" PLASTIC LUMBER	2'-0" (STRAIGHT)	10.7		
H1	2" X 6" PLASTIC LUMBER	PILE CUTOFF ELEV. MINUS NLW OR MLW ELEV. PLUS 5'-6" (STRAIGHT)	1.0 PER LF EACH		
H2	2" X 6" PLASTIC LUMBER	1'-0" (STRAIGHT)	1.0		

