

**DETAIL A - FACE INSPECTED ANCHOR WITH GROUT OUTLET**

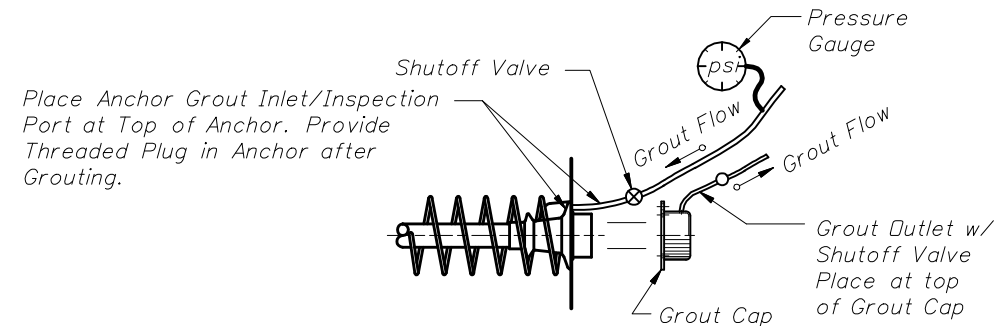

**FACE INSPECTED ANCHOR WITH GROUT INLET**

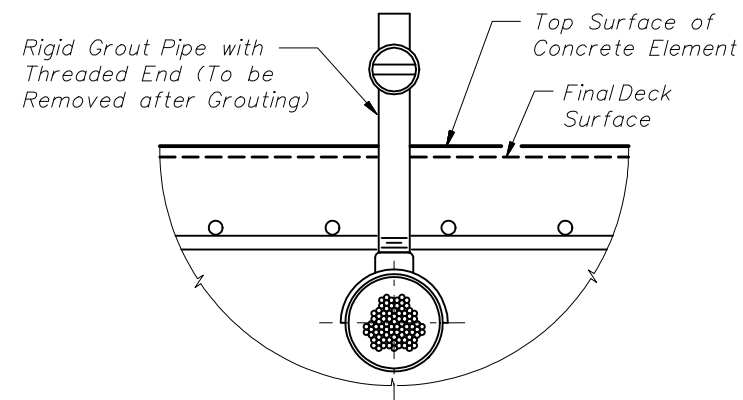

**1 GROUT OUTLET CONNECTION TO TENDON**

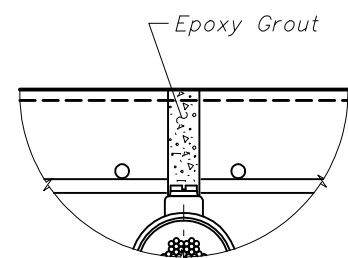

**3 FILLING POCKET**

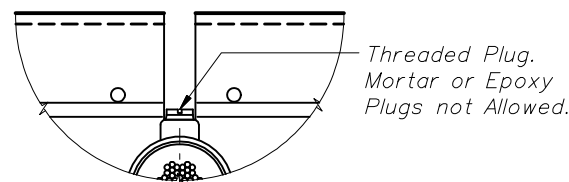

**2 POCKET PREPARATION**

**PROCEDURE**

1. Remove Rigid Grout Pipe.
2. Inspect Tendon for Voids as Necessary.
3. Vacuum Grout as Required and Allow Grout to Cure. Remove Pipe used for Vacuum Grouting.
4. Clean Threads and Rethread as Required.
5. Install Threaded Plug into Outlet to Form a Tight Fit.
6. Over-Ream Hole (1/4"  $\phi$  Over-Ream) Clean and Roughen Sides.
7. Fill Pocket with Epoxy Grout.

**GROUT OUTLET DETAIL AT HORIZONTAL SURFACES**

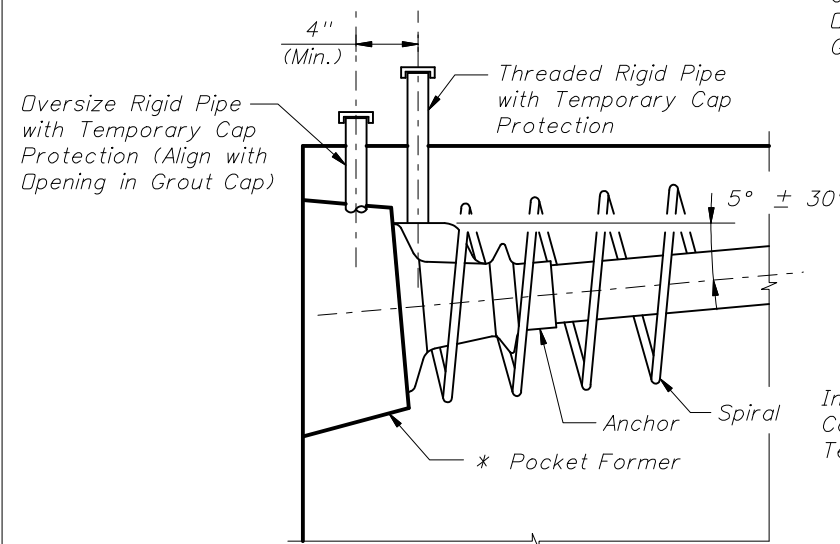

**1 INSTALLATION & SHIPPING**

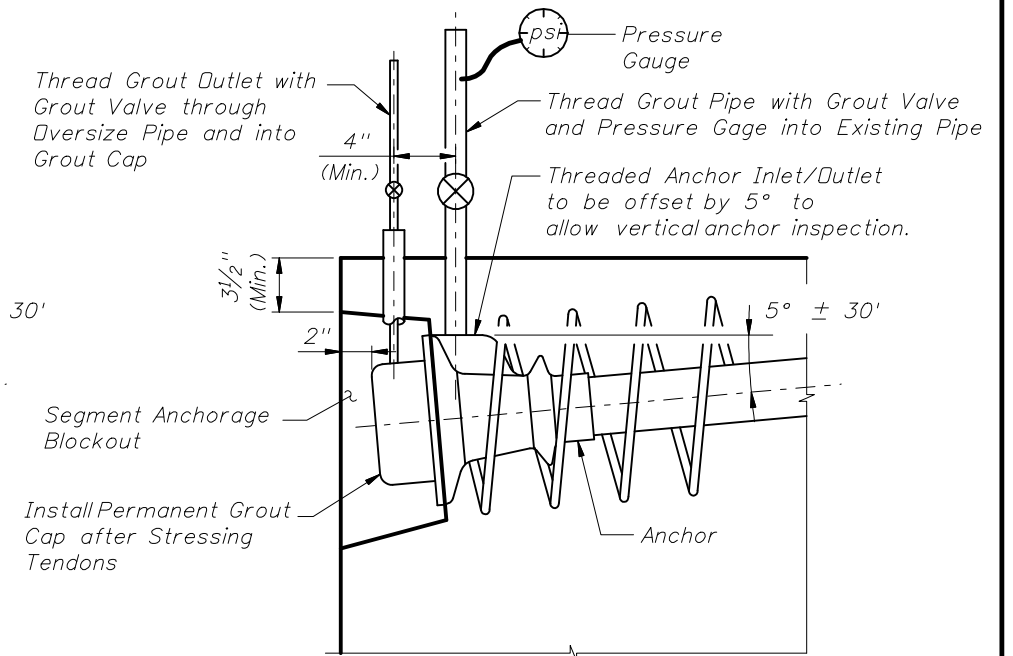

**2 GROUTING**

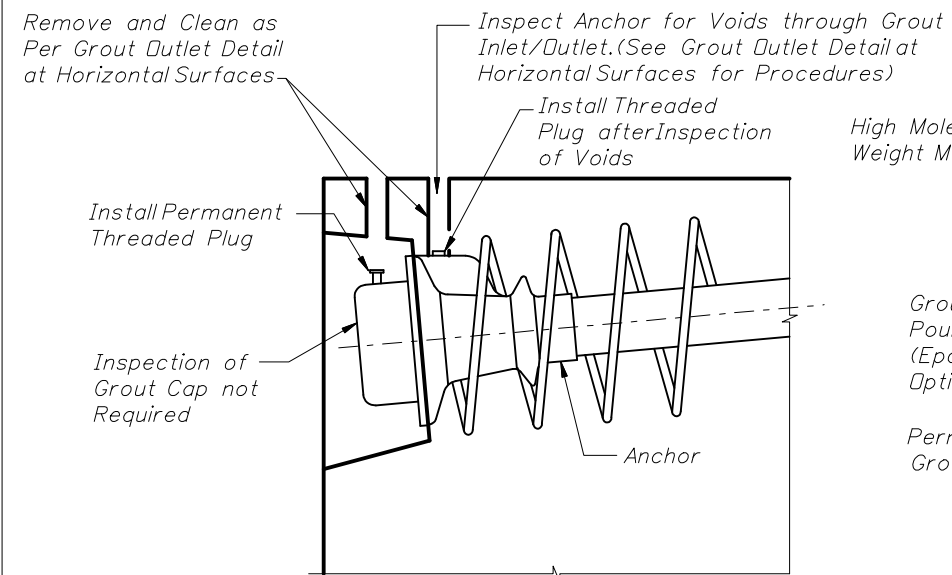

**3 INSPECTION**

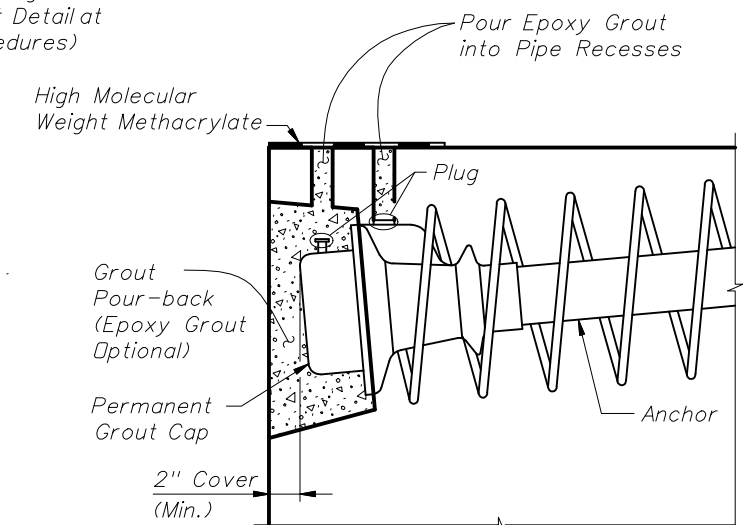

**4 PROTECTION**

**NOTES**

1. Holes used for the Inspection and Grout Inlets/Outlets may be Formed using Tapered Pipes or Mandrels.

**TOP INSPECTED ANCHOR WITH GROUT INLET INSTALLATION, GROUTING, INSPECTION & PROTECTION**

- \* Round Pocket Former - Gravity Fed Placement of Grout Acceptable
- Modified Square Pocket Former - Gravity Fed Placement of Grout Acceptable
- Square Pocket Former - Vacuum Grouting Required

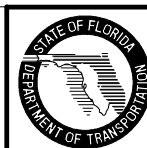

2010 FDOT Design Standards

**POST-TENSIONING ANCHORAGE AND GROUTING DETAILS**

Last Revision	Sheet No.
01/01/09	1 of 3
Index No.	
21803	

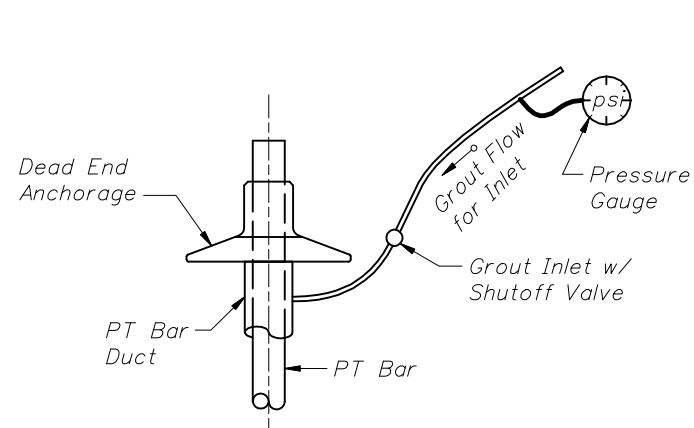

PT BAR  
ANCHORAGE NON-STRESSING END

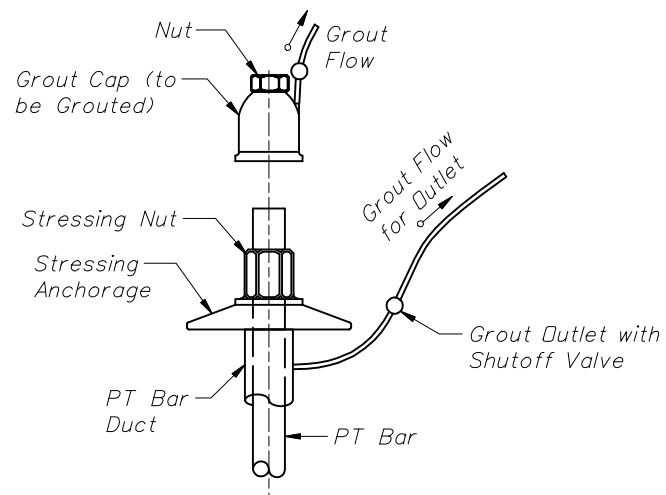

PT BAR  
ANCHORAGE STRESSING END

NOTE:  
Stressing Anchorage or Nut to allow for Flow of Grout into Cap.

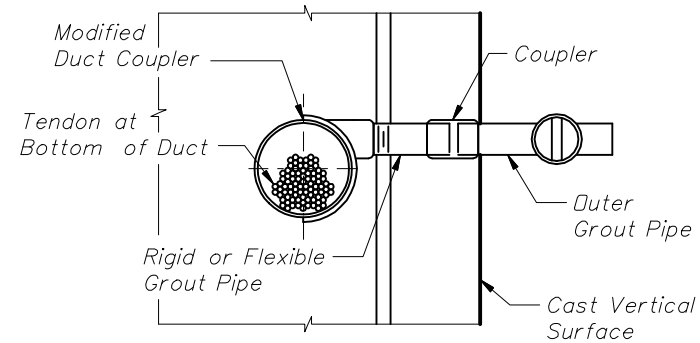

① GROUT OUTLET CONNECTION TO TENDON

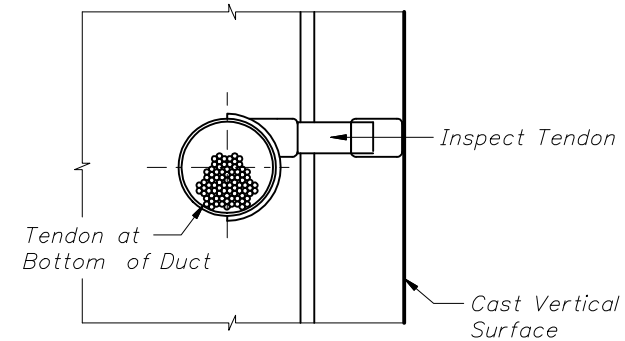

② POCKET PREPARATION

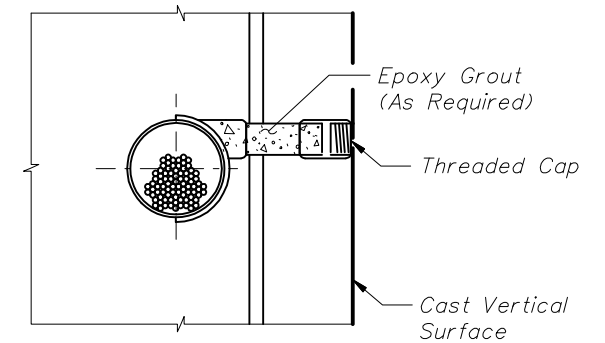

③ FILLING POCKET

PROCEDURE

1. Remove Rigid Grout Pipe. or Drill Grout in Flexible Pipe.
2. Inspect Tendon for Voids as Necessary.
3. Vacuum Grout as Required and Allow Grout to Cure for 24 hr. (min.). Remove Pipe used for Vacuum Grouting.
4. Plug Recess with Threaded Cap on Inside Surfaces of Box Sections and Inside (nonfascia) Surfaces of I-Girders. For all other Surfaces, Plug Recess with both Threaded Cap and Epoxy Grout.

GROUT OUTLET DETAIL AT VERTICAL SURFACES

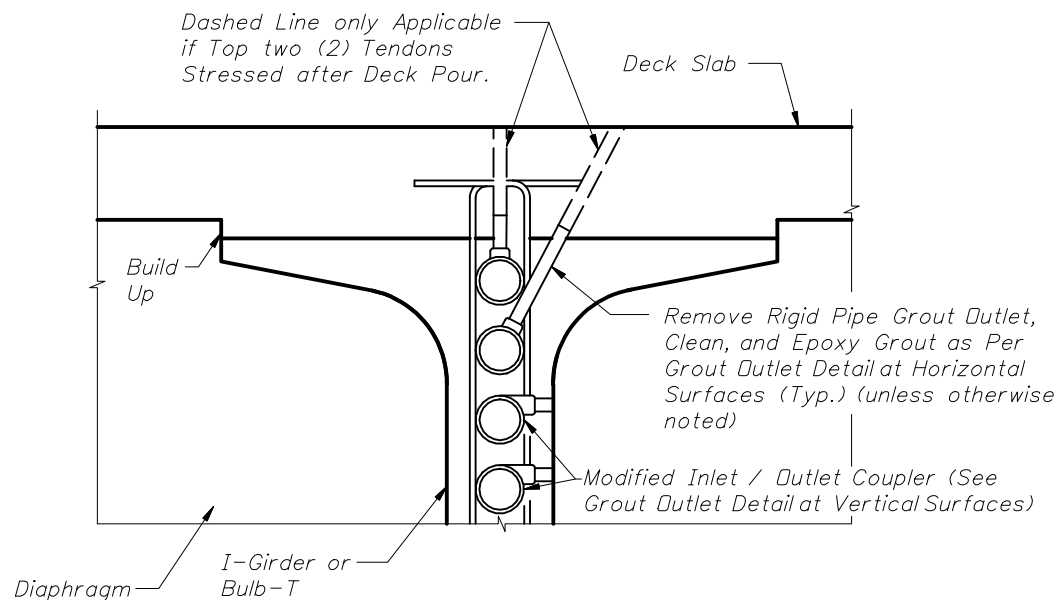

HIGH POINT INSPECTION  
LOCATION AT GROUT OUTLET

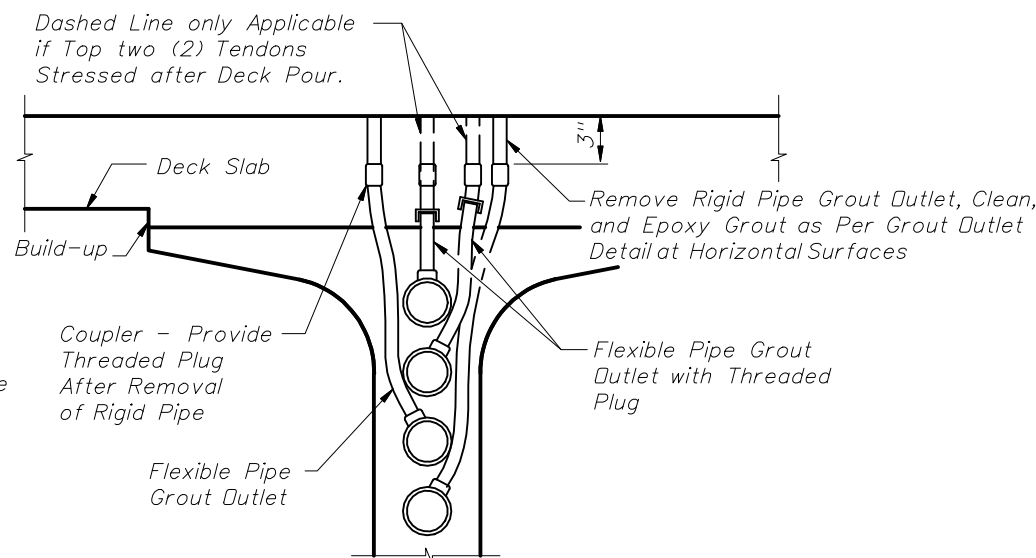

Web Reinforcing not Shown for Clarity  
TENDONS AT 3' TO 6'  
FROM HIGH POINTS (GROUT OUTLET)

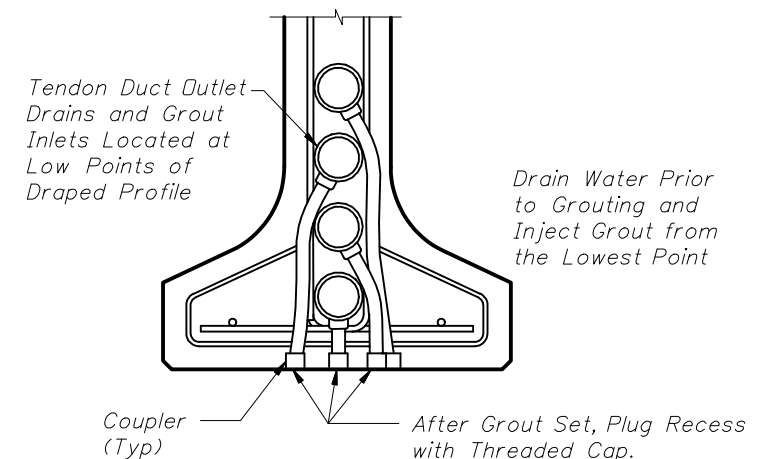

TENDONS AT LOW POINTS  
(GROUT INLET / DRAIN)

Details Shown for I-Girders/Bulb-T's - Details for C.I.P. Boxes with Internal Tendons Similar



2010 FDOT Design Standards

**POST-TENSIONING ANCHORAGE  
AND GROUTING DETAILS**

Last Revision 01/01/09 Sheet No. 2 of 3

Index No. 21803

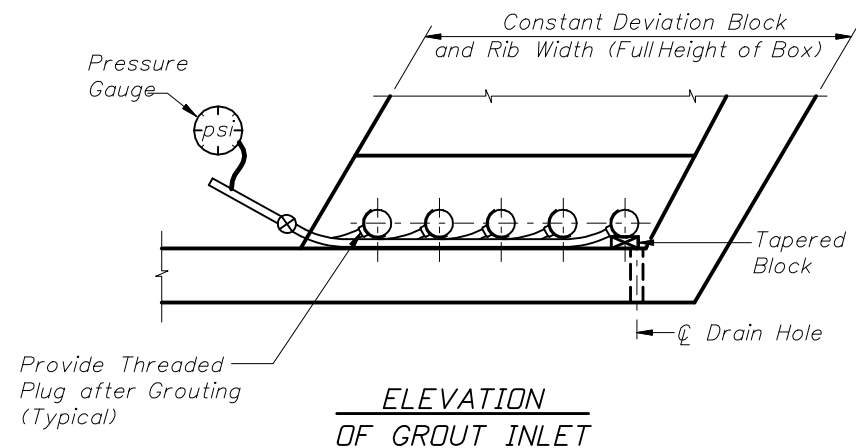

NOTES:  
Place Tapered Blocks Under Each Tendon to be Grouted to Raise Duct off Tendon Strands. Center Strands within Duct before Grouting. Blocks Shall be Removed after Grout has Set. Blocks Shall not Damage or Permanently Deform Duct.

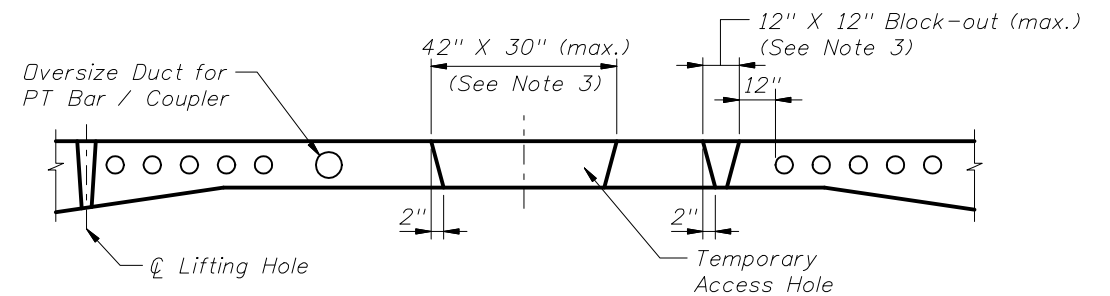
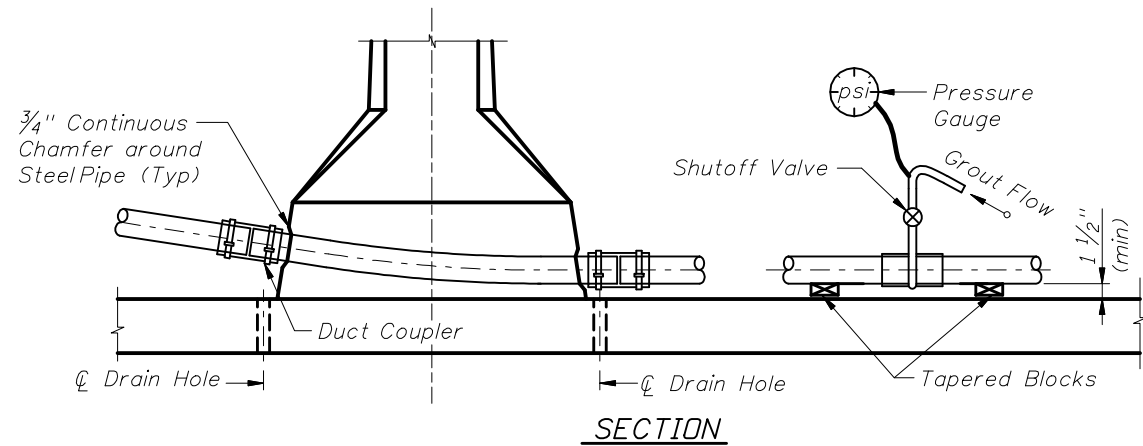

Notes: Temporary Access Holes

1. Temporary access holes to facilitate access for erection, jacking and grouting operations inside the box during construction are allowed. The access holes shall be limited to a maximum size of 42" wide x 30" long and shall be limited to (1) per span.
2. Slab block-outs for temporary / permanent longitudinal post-tensioning bars are not allowed. Temporary / permanent PT bars in the top slab shall be placed in oversized ducts in the slab to accommodate both the bar and coupler.
3. In lieu of (1) 42" x 30" temporary access hole, a maximum of 2 top slab blockouts (12" x 12" (max.)) between the webs is allowed for construction per span. Block-outs shall be a minimum of 12" from the nearest duct or anchor and shall be located as to prevent direct drip onto bottom slab anchors.

Notes: Repair of Temporary Access Holes, Block-outs, and Lifting Holes

1. Form all large blockouts with tapered sides.
2. Immediately before casting the concrete, mechanically clean the mating concrete surfaces to remove any laitance and to expose small aggregate.
3. Repair all holes and blockouts with Magnesium Ammonium Phosphate Concrete within 24 hours of cleaning concrete.
4. After completion of the deck grooving, coat the repaired and surrounding concrete surfaces with High Molecular Weight Methacrylate.
5. Alternately, epoxy grout may be used to repair holes. High Molecular Weight Methacrylate is not required with epoxy grout.

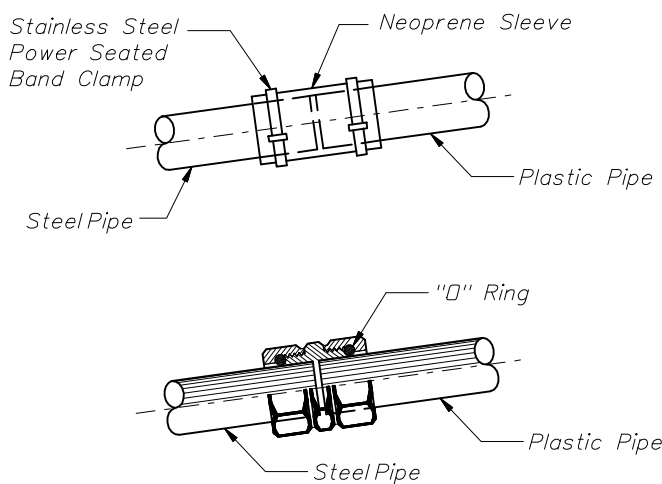

DUCT COUPLER DETAIL  
Use Approved Duct Couplers with Post-Tensioned System

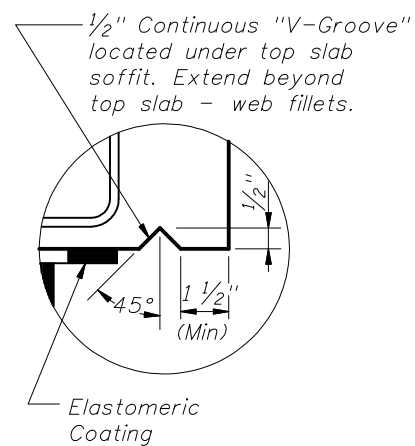

DETAIL OF DRIP LEDGE AT ABUTMENTS AND EXPANSION JOINTS FOR SEGMENTAL AND CAST-IN-PLACE BOX CONSTRUCTION

