

PARTIAL VIEW A-A

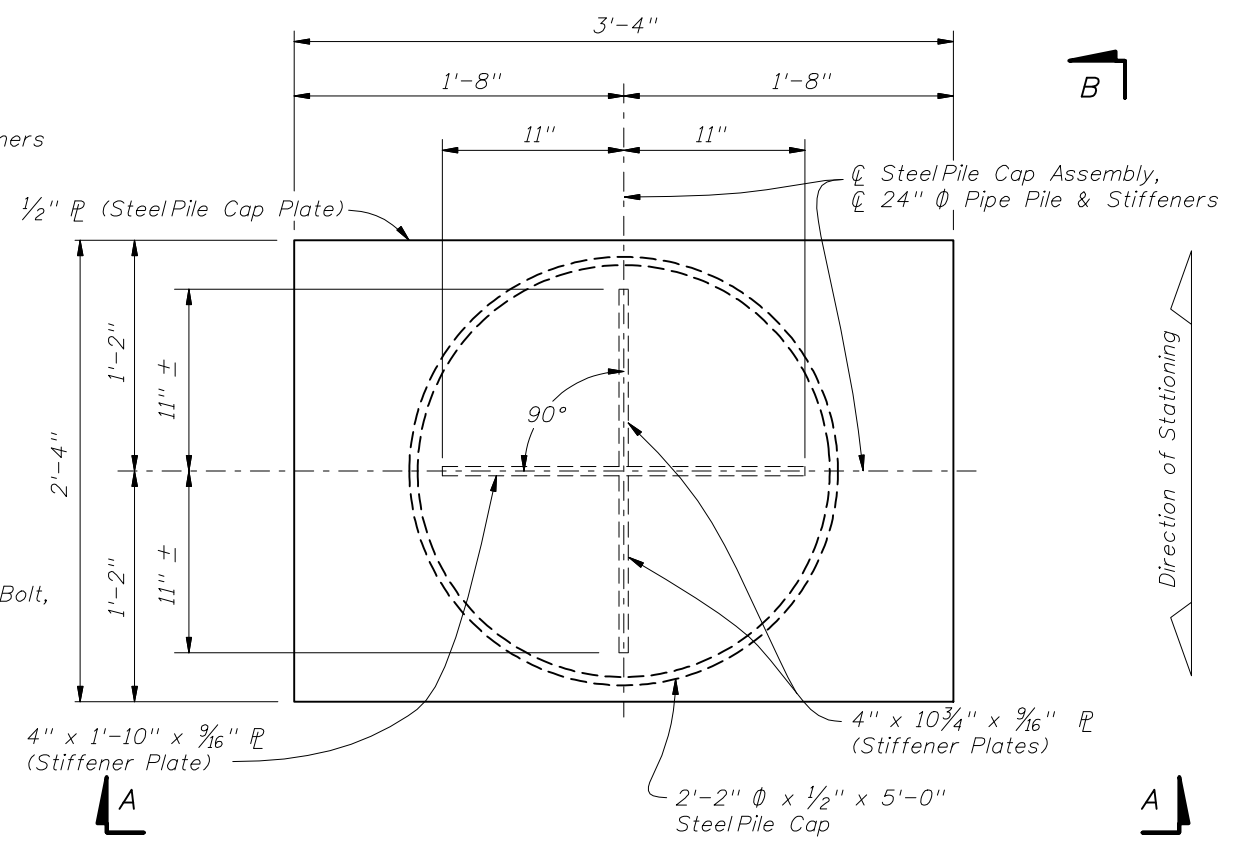

PLAN VIEW STEEL PILE CAP ASSEMBLY
(Bearing Plates and Bearing Keeper Bars not show for clarity)

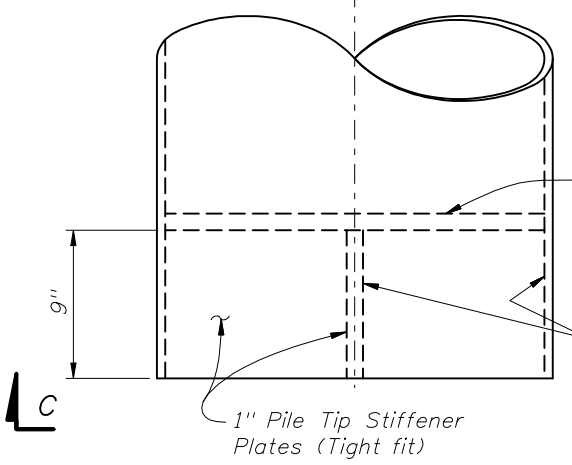

VIEW B-B

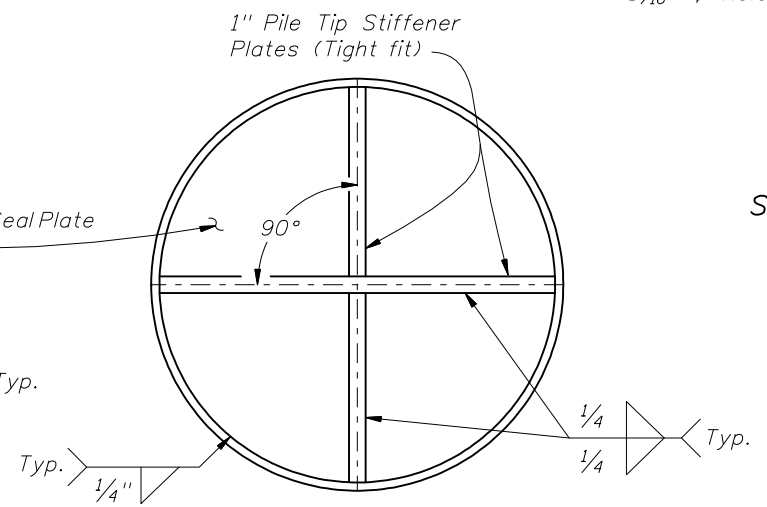

VIEW C-C
PILE TIP DETAIL

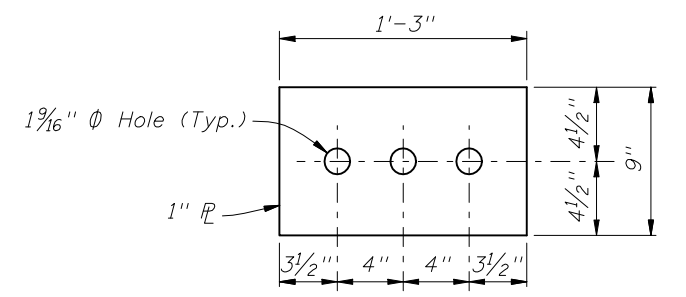

STRUT CONNECTOR PLATE DETAIL

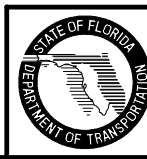

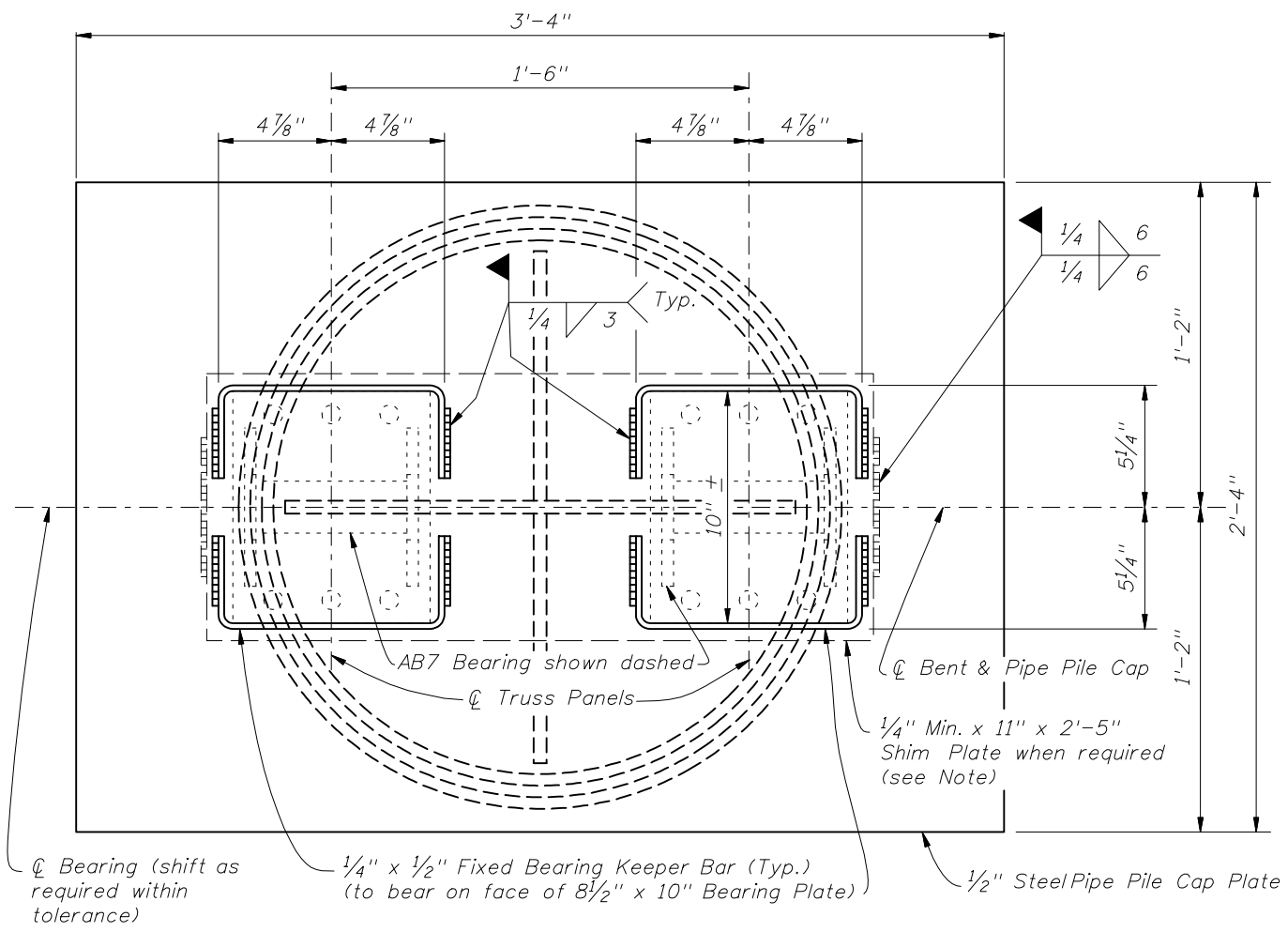

PARTIAL PLAN VIEW

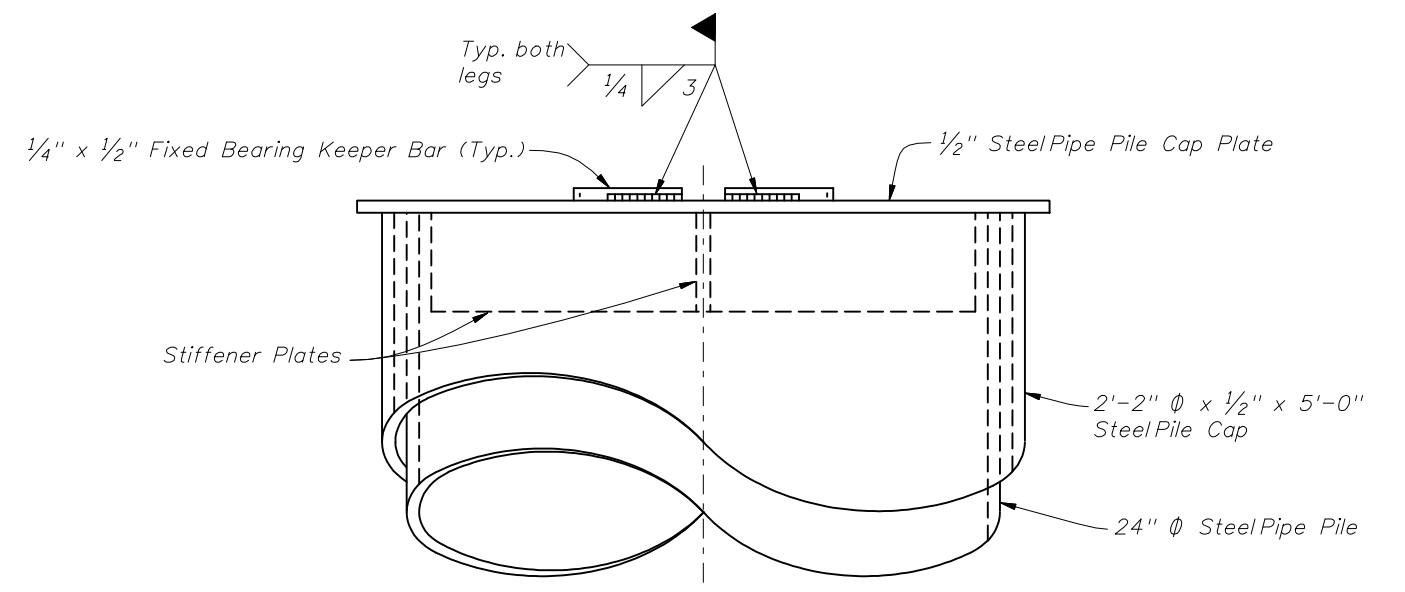

END VIEW

Note:
Use Shim Plates as required to provide equal bearing seat elevations across the bent. Vary thickness of Shim Plate across the pile cap plate to provide a level bearing area in the transverse direction.

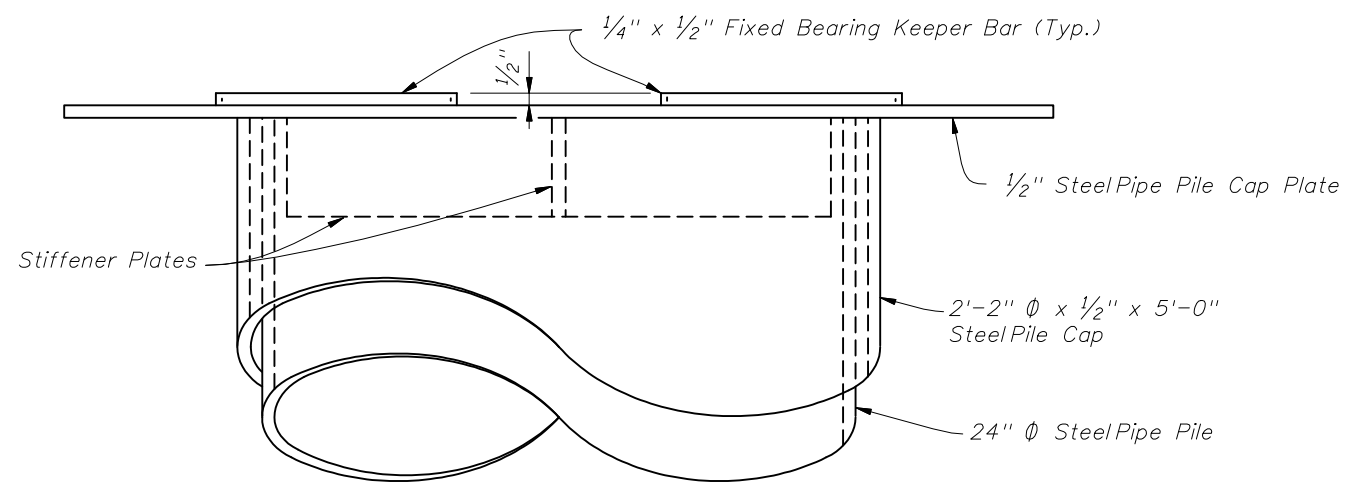

PARTIAL ELEVATION VIEW

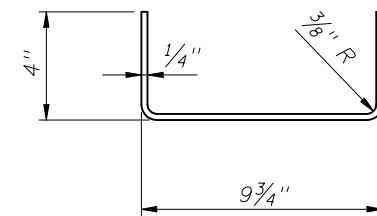

FIXED BEARING KEEPER BAR DETAIL

FIXED BEARING DETAILS

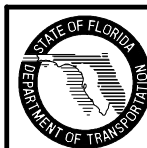

2010 FDOT Design Standards

TEMPORARY DETOUR BRIDGE DETAILS
STEEL PIPE PILE FOUNDATIONS

Last Revision	Sheet No.
07/01/06	2 of 3
Index No.	
21630	

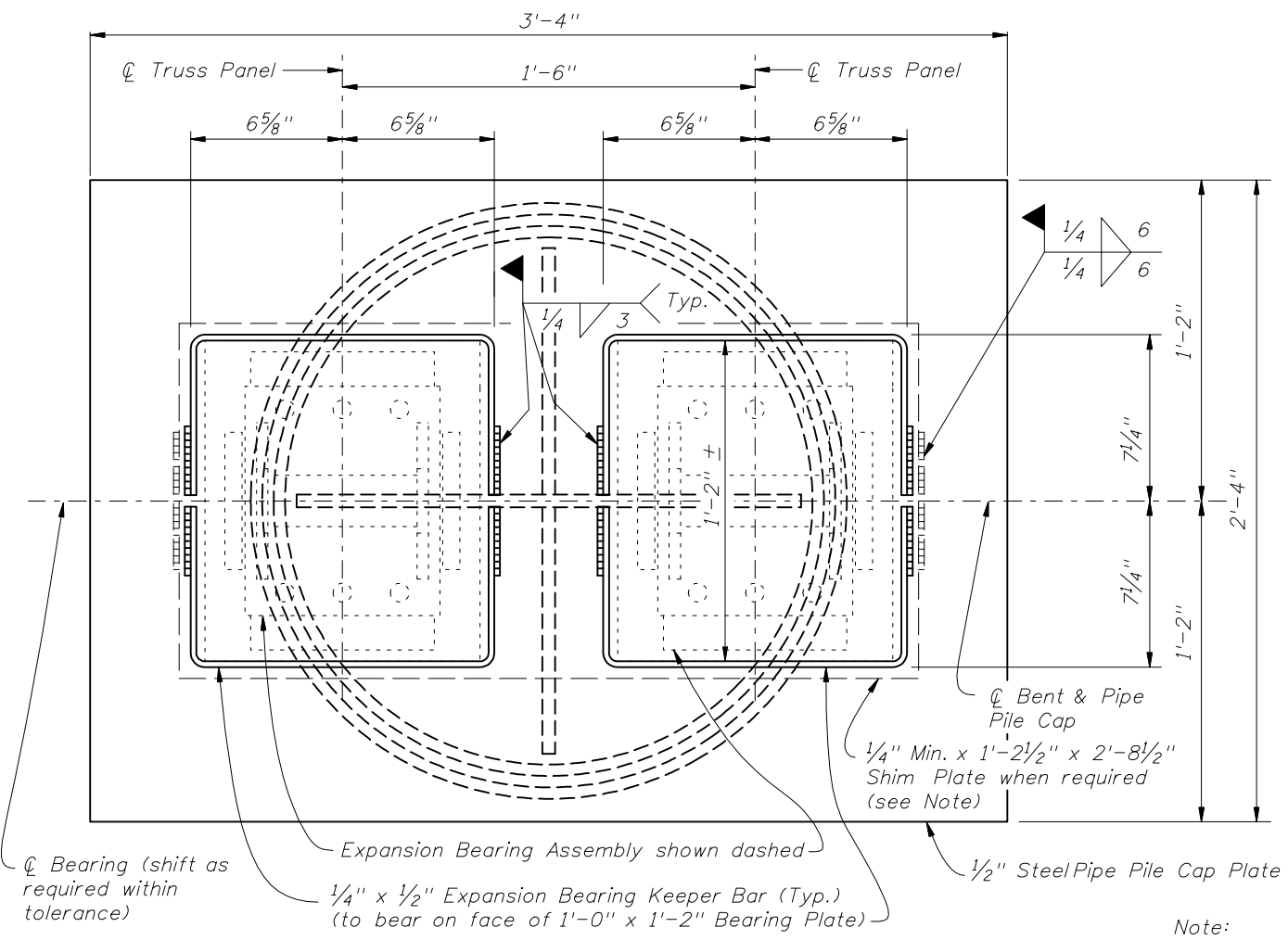

PARTIAL PLAN VIEW

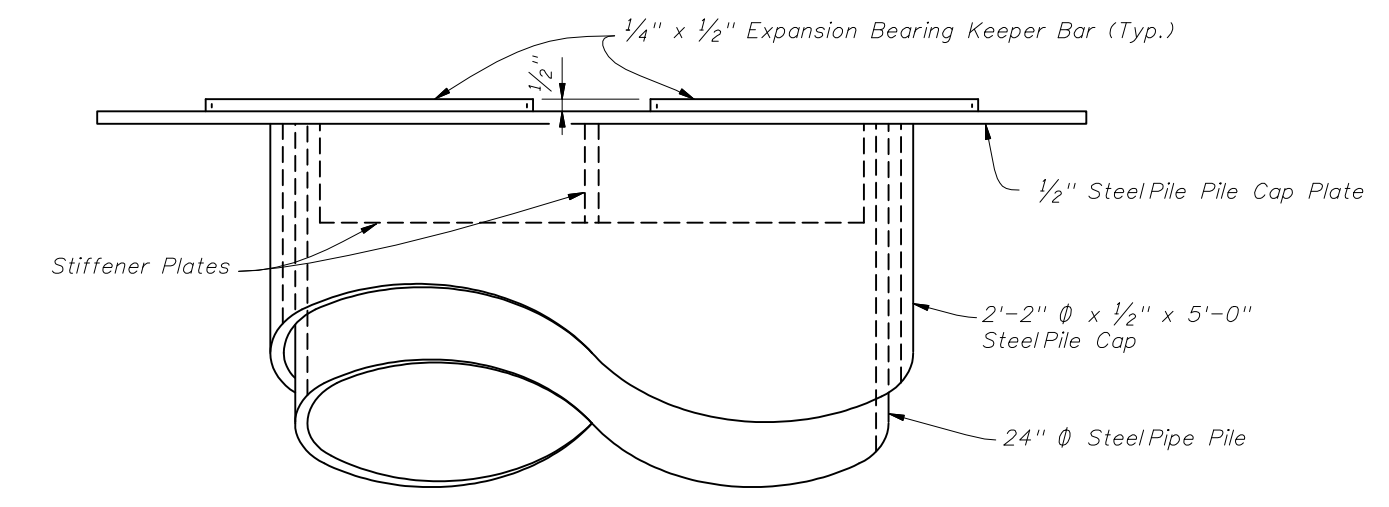

PARTIAL ELEVATION VIEW

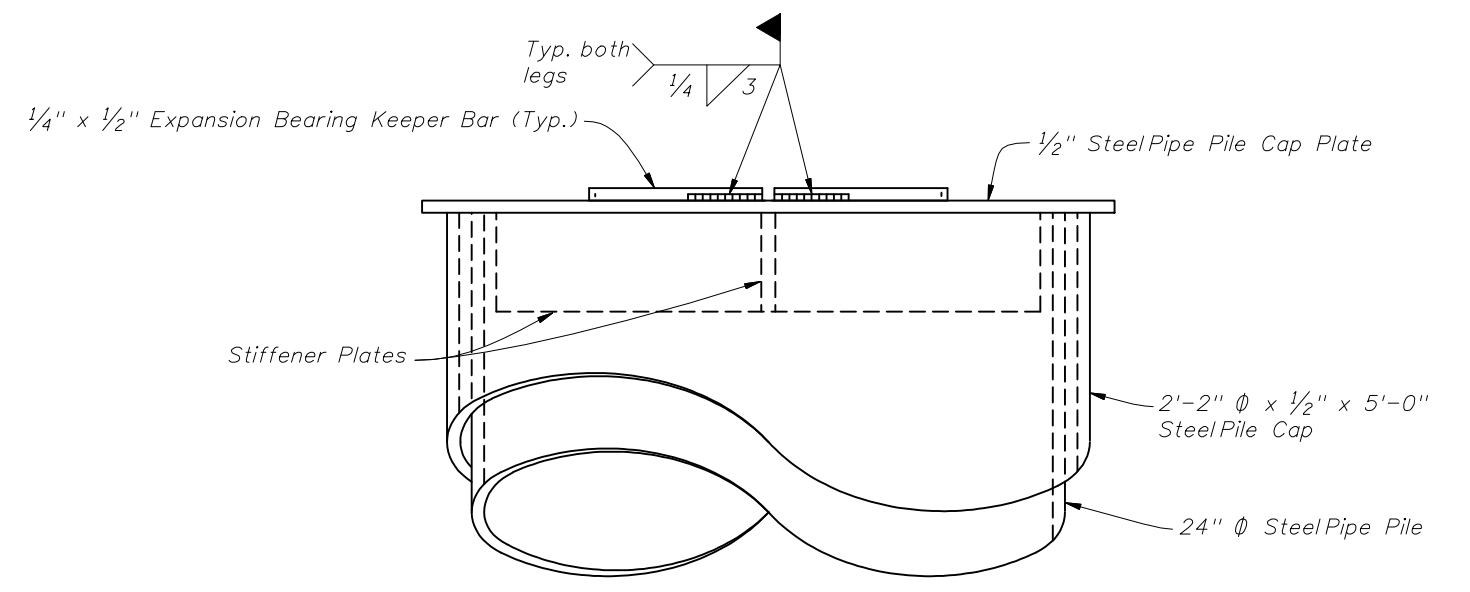

END VIEW

Note:
Use Shim Plates as required to provide equal bearing seat elevations across the bent. Vary thickness of Shim Plate across the pile cap plate to provide a level bearing area in the transverse direction.

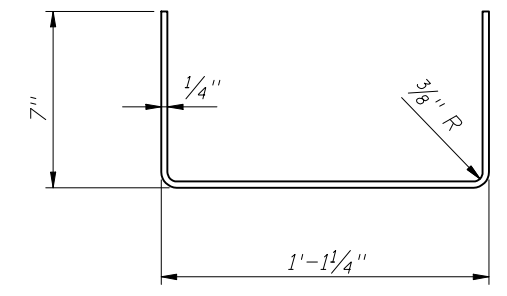

EXPANSION BEARING KEEPER BAR DETAIL

ABUTMENT AND INTERMEDIATE EXPANSION BEARING DETAILS

