

PLAN VIEW

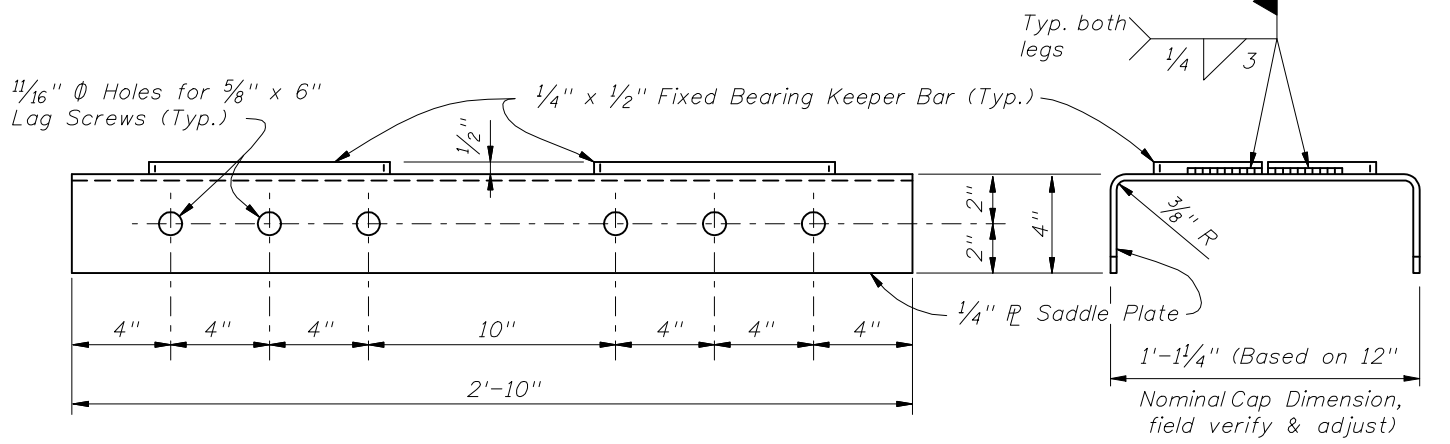

ELEVATION VIEW OF SADDLE PLATE

END VIEW

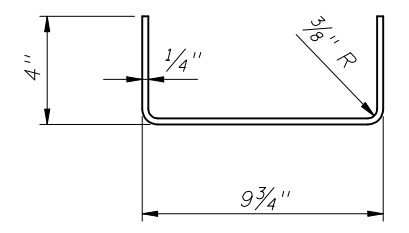

FIXED BEARING KEEPER BAR DETAIL

===== FIXED BEARING DETAILS =====

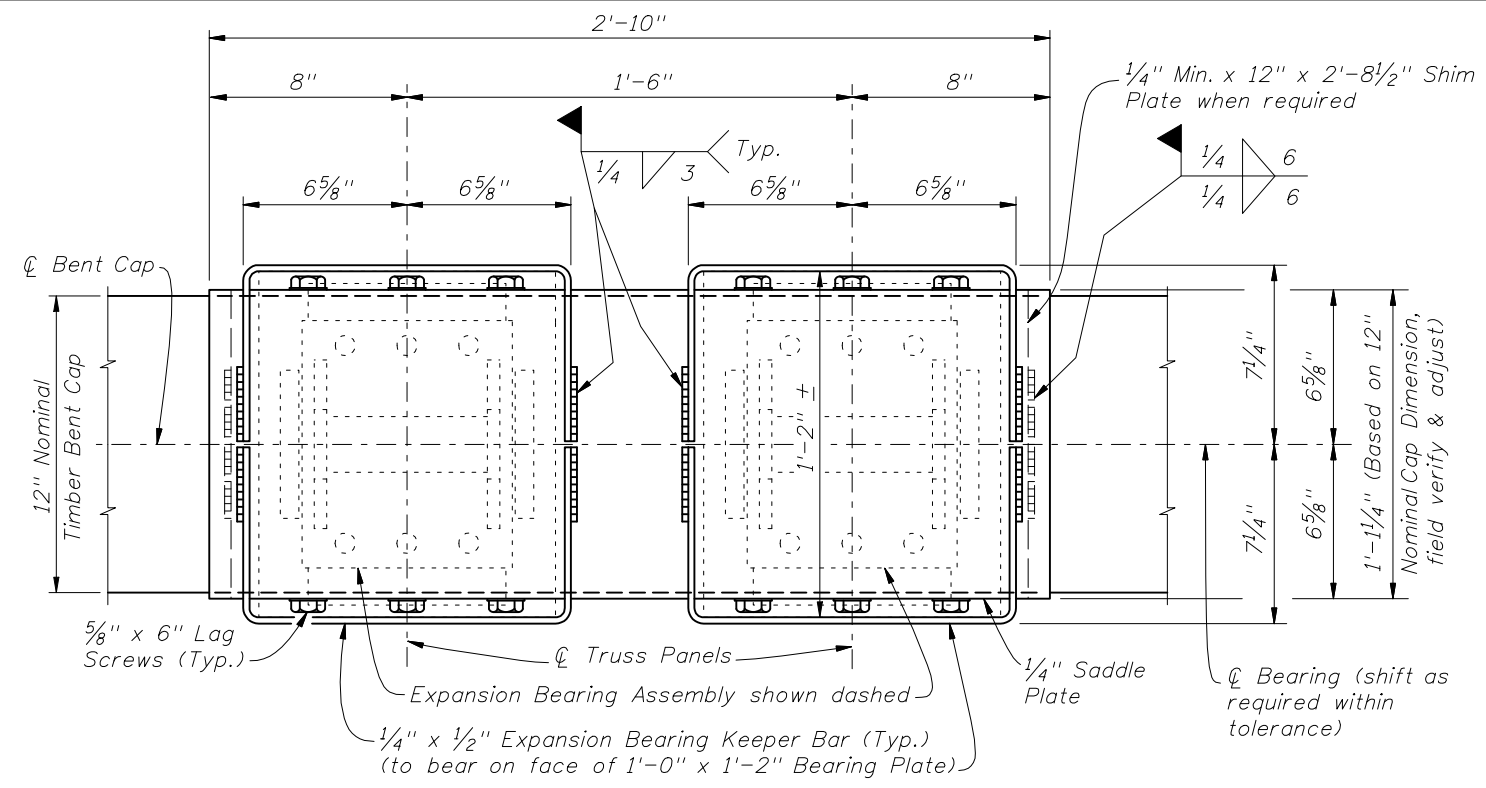

PLAN VIEW

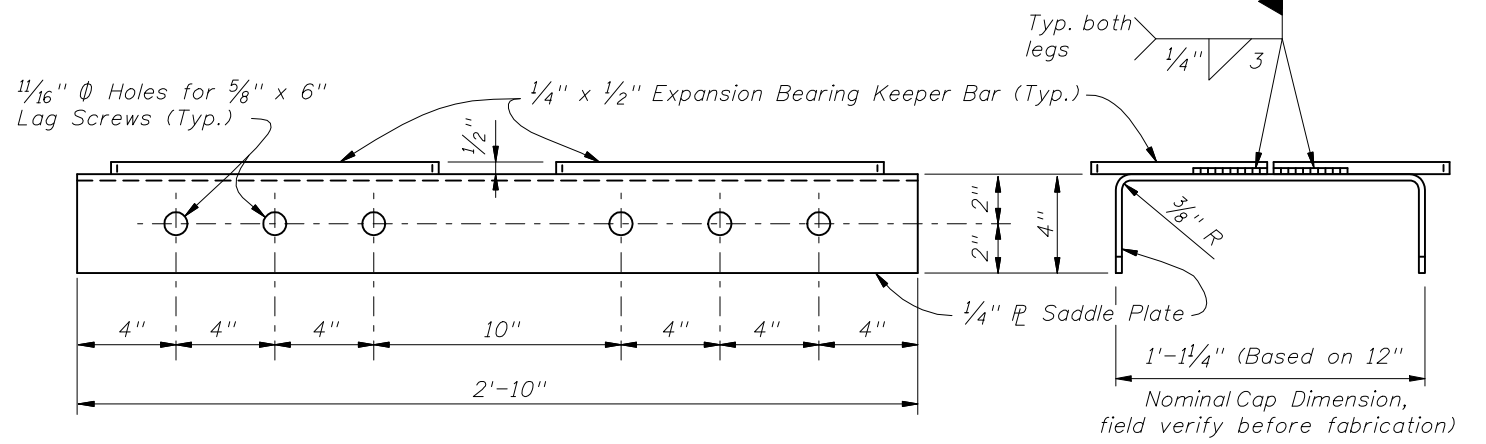

ELEVATION VIEW OF SADDLE PLATE

END VIEW

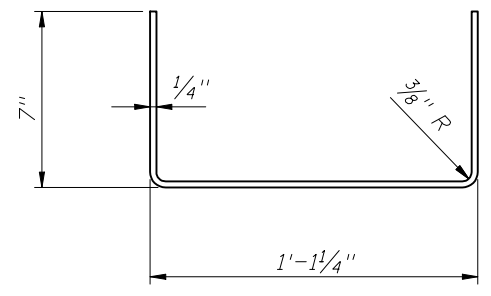

EXPANSION BEARING KEEPER BAR DETAIL

===== EXPANSION BEARING DETAILS =====

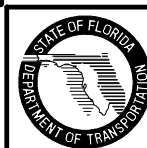

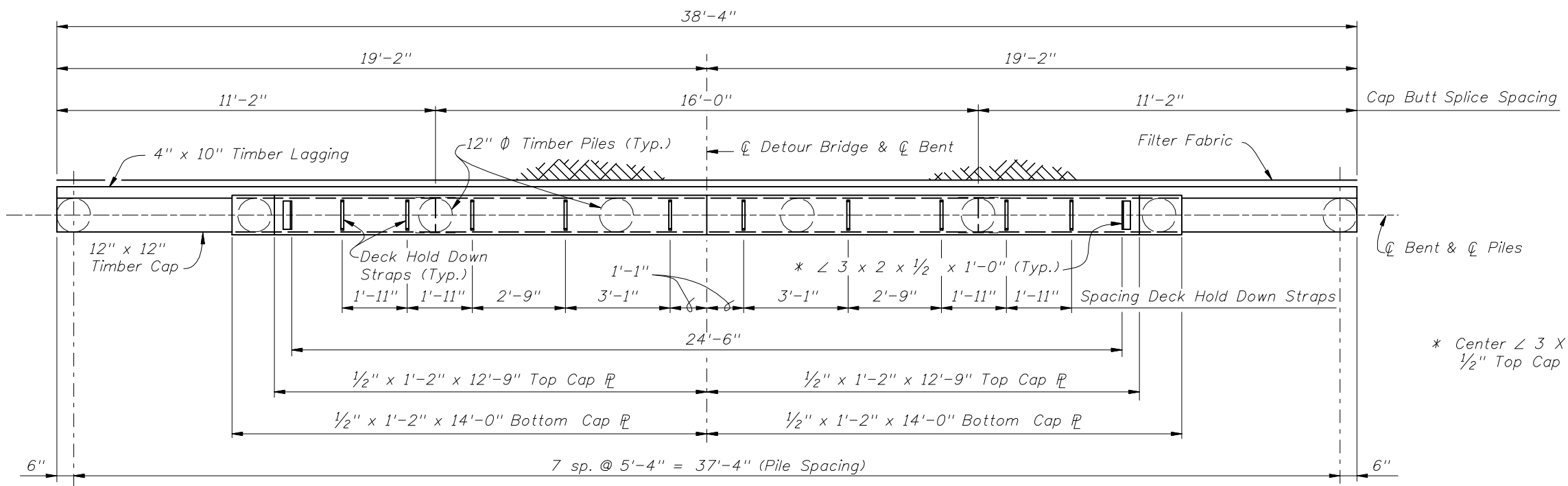

PLAN VIEW

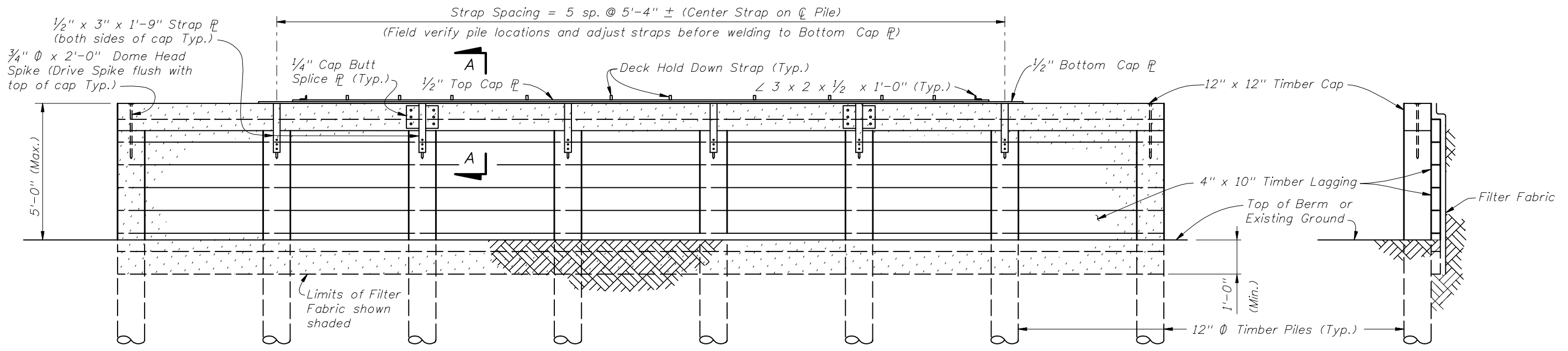

ELEVATION VIEW

END VIEW

BACKWALL BENT DETAILS



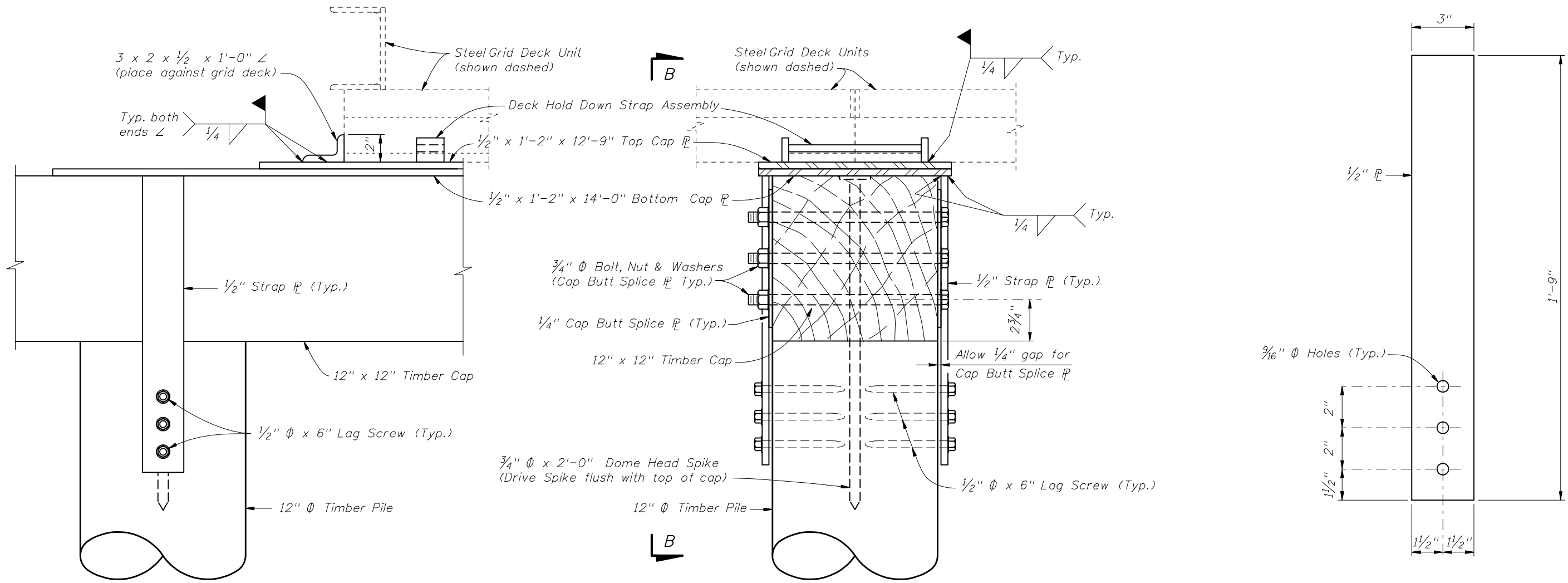

VIEW B-B  
 (SHOWING END OF CAP PLATES)

SECTION A-A

STRAP PLATE DETAIL

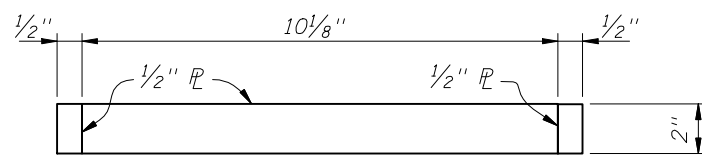

PLAN VIEW

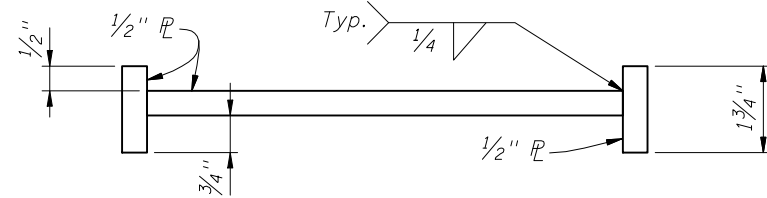

ELEVATION VIEW

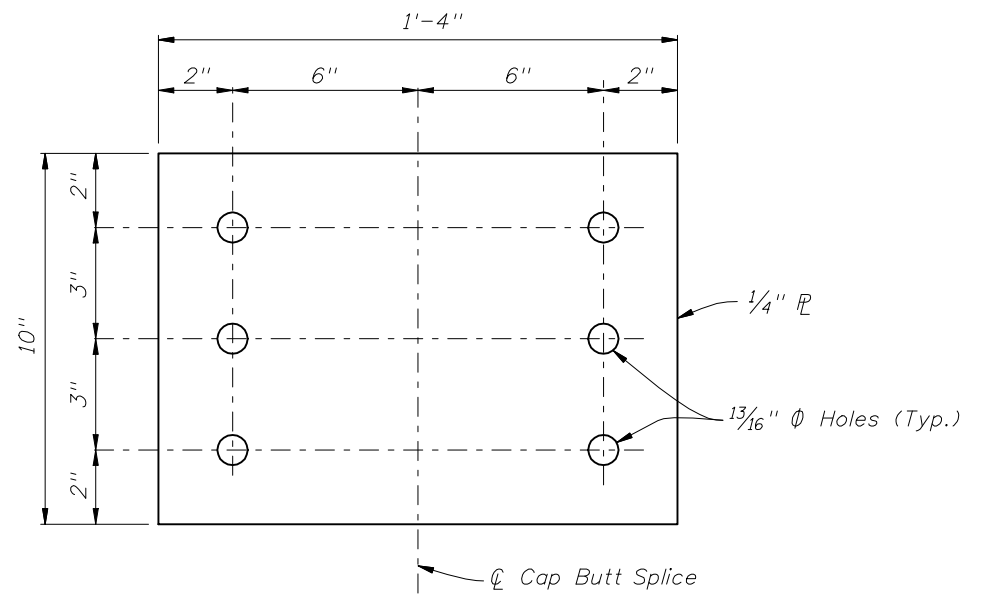

CAP BUTT SPLICE PLATE DETAIL

==== HOLD DOWN STRAP ASSEMBLY DETAIL ====

==== BACKWALL BENT DETAILS ====

