

PLAN

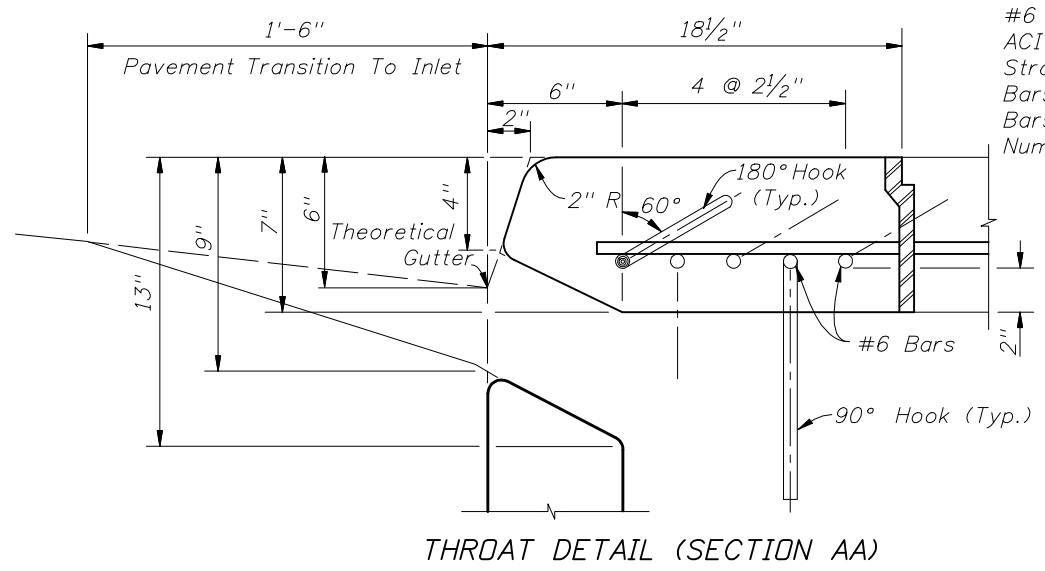

#6 Bars
 ACI Std. Hooks Required Each End Of
 Straight Bars And Right End Of Bent
 Bars. 180° Hooks, Canted 60° (+), On Odd
 Bars; 90° Hooks, Down, On Even Bars
 Numbered From Throat Side.

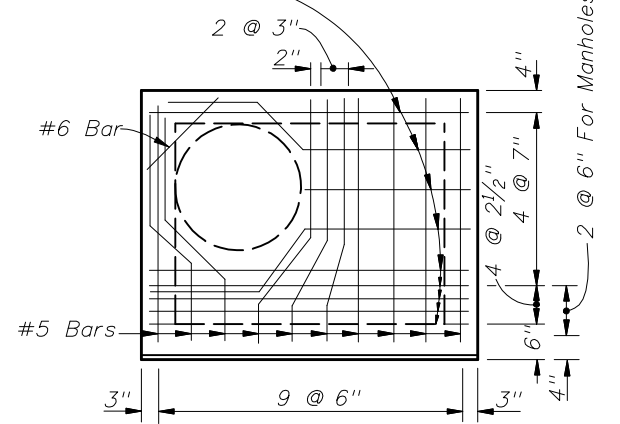

REINFORCING STEEL DIAGRAM
 TOP SLAB OF INLET

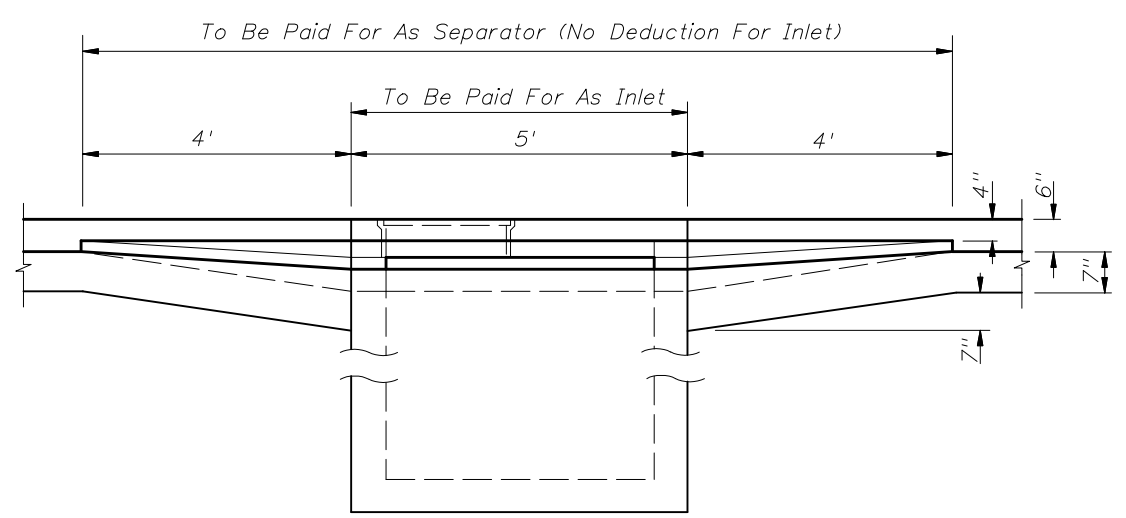

SECTION CC

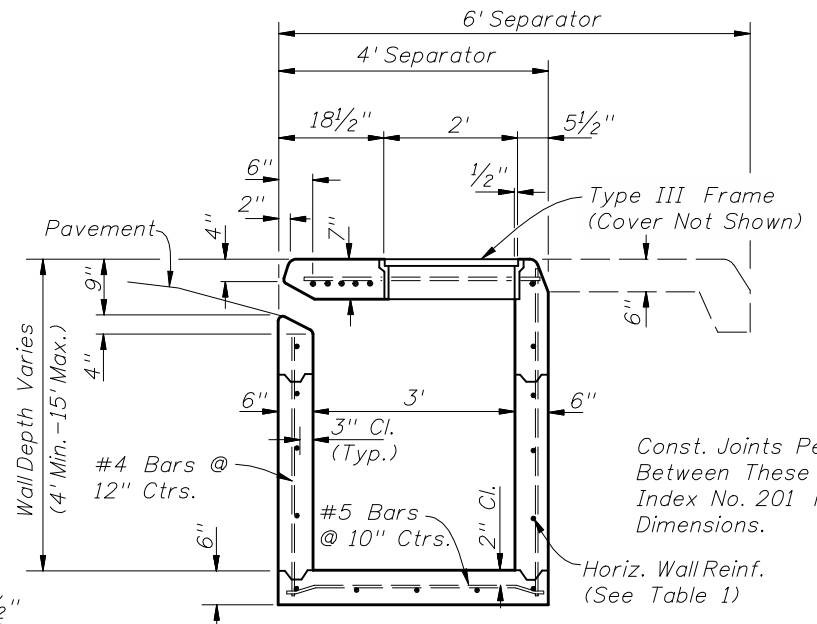

SECTION AA

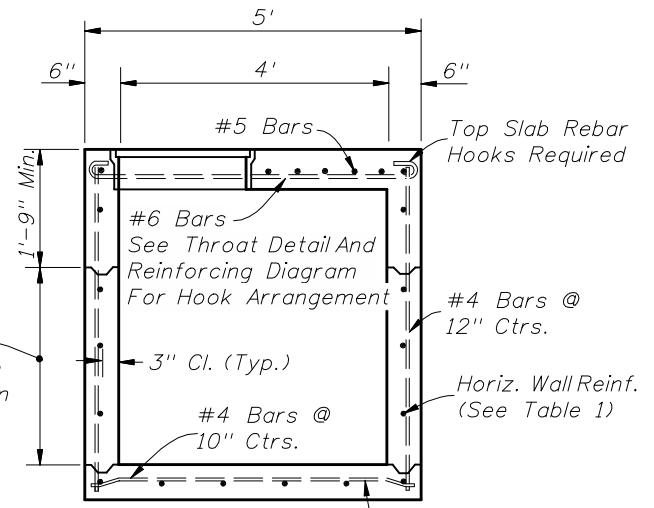

SECTION BB

GENERAL NOTES

1. This inlet is to be used only in Traffic Separators Types IV and V; or, in separators constructed with Curbs Types D and F and sidewalk paving, which cannot accommodate Inlets Types 1, 2, 3, 4, 5 or 6. Use of this inlet on the through traffic side of the separator should be avoided in medians constructed with Curb Type D (Curb inlets Types 9 or 10 are recommended). Locate inlet outside of designated pedestrian travelway.
2. All reinforcing to be Grade 60 bars with 2" min. cover unless otherwise shown. See Index No. 201 for equivalent area of welded wire fabric. Cut or bend bars out of way of pipe when necessary. Bars to clear pipe by 1 1/2".
3. Recommended maximum pipe sizes are 24" longitudinal and 30" transverse. For larger pipe, inlets with Alt. B bottoms, Index No. 200 are recommended.
4. For supplemental details see Index No. 201.
5. All dimensions are for both precast and cast-in-place inlets unless otherwise shown.
6. Inlet to be paid for under the contract unit price for Inlets (Curb) (Type 8), Each.

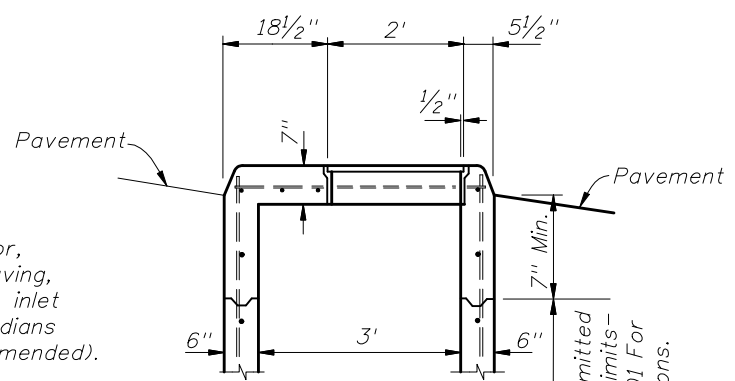

MODIFICATION WHEN USED
 AS A MANHOLE

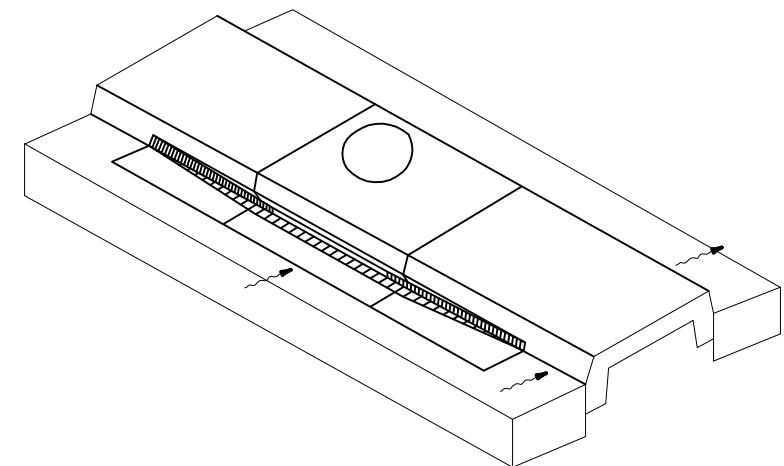

**HORIZONTAL WALL REINFORCING
 SCHEDULE (TABLE 1)**

WALL DEPTH	SCHEDULE	AREA (in. ² /ft.)	MAX. SPACING	
			BARS	WWF
0' - 6'	A12	0.20	12"	8"
6' - 10'	A6	0.20	6"	5"
10' - 13'	A4	0.20	4"	3"
10' - 15'	B5.5	0.24	5 1/2"	5"

