

GENERAL NOTES:

1. Furnish Poured Joint With Backer Rod Expansion Joint Systems in accordance with Specification Section 458 and 932. Furnish joint systems consisting of Poured Joint Material, Foam Backer Rods, Sidewalk Cover Plates (as required) and all associated miscellaneous components.
2. When required, furnish 1/4" thick slip resistant steel Sidewalk Cover Plates in accordance with ASTM A709, Grade 36 or 50, with a minimum coefficient of friction after galvanizing on the top surface of 0.8 in a dry condition as determined by ASTM F1677 or F1679 and 0.68 or 0.52 in a wet condition as determined by ASTM F1679 or ASTM F1677 (respectively); that incorporate an anti-slip steel surface consisting of a random hatch matrix or other suitable pattern. Do not use diamond plate or surface applied slip resistant tapes, films, nonmetallic coatings or other similar materials. Furnish flat head Stainless Steel Sleeve Anchors in accordance with ASTM F593 Group 1 Alloy 304 for attaching Sidewalk Cover Plates. Install Sleeve Anchors in accordance with manufacturer's recommendations.
3. Hot-dip galvanize Sidewalk Cover Plates after shop fabrication in accordance with Section 962 of the Specifications and manufacturer's recommendations.
4. Submit shop drawings for Sidewalk Cover Plates (as required) showing all materials and project specific details and dimensions.
5. Manufacturers seeking approval of Poured Joint with Backer Rod Expansion Joint Systems for inclusion on the Qualified Products List as pre-approved designs must submit application along with design documentation showing the expansion joint meets the specification, geometric and material requirements specified herein.
6. Refer to Specification Section 458 for installation and construction requirements.
7. Refer to the Structures Plans, Poured Expansion Joint Data Table for Dim. "A" @ 70° F.

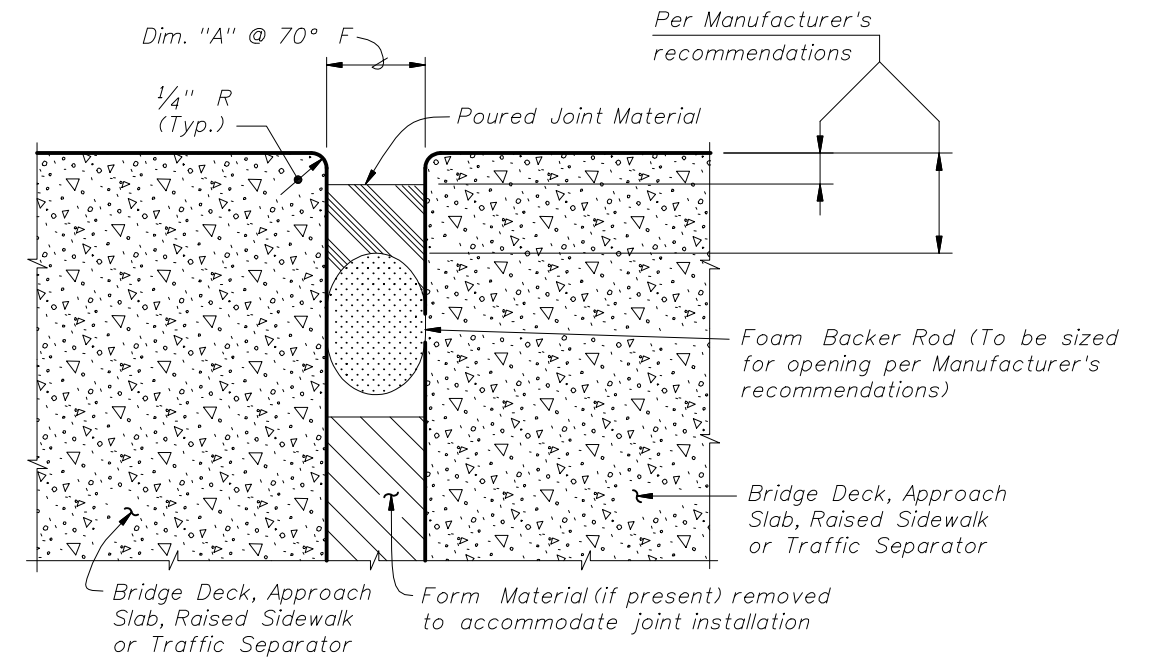

TYPICAL SECTION THRU JOINT

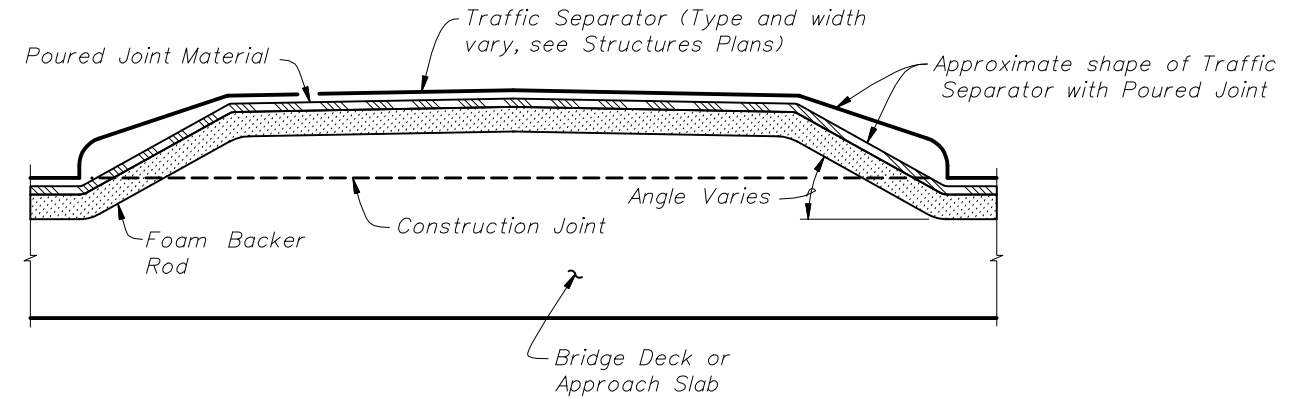

PARTIAL SECTION ALONG C/J JOINT, JOINT TREATMENT AT TRAFFIC SEPARATOR

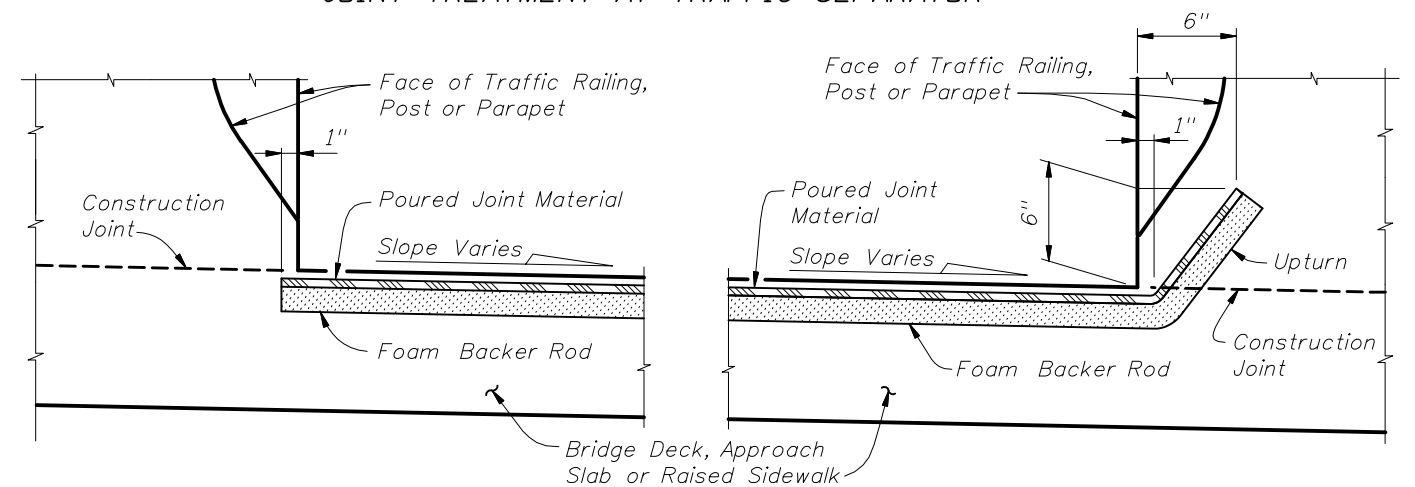

PARTIAL SECTION ALONG C/J JOINT JOINT TREATMENT AT HIGH SIDE OF DECK WITH SLOPES 2% OR GREATER

PARTIAL SECTION ALONG C/J JOINT JOINT TREATMENT AT LOW SIDE OF DECK OR HIGH SIDE OF DECK WITH SLOPES < 2%

INSTRUCTIONS TO DESIGNER:

Allow for a minimum (fully closed) opening of 50% of Dimension "A" and a maximum opening of 3" (measured in the direction of travel).

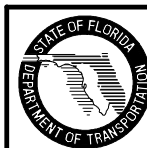

2010 FDOT Design Standards

POURED JOINT WITH BACKER ROD EXPANSION JOINT SYSTEM

Last Revision

01/01/09

Sheet No.

1 of 2

Index No.

21110

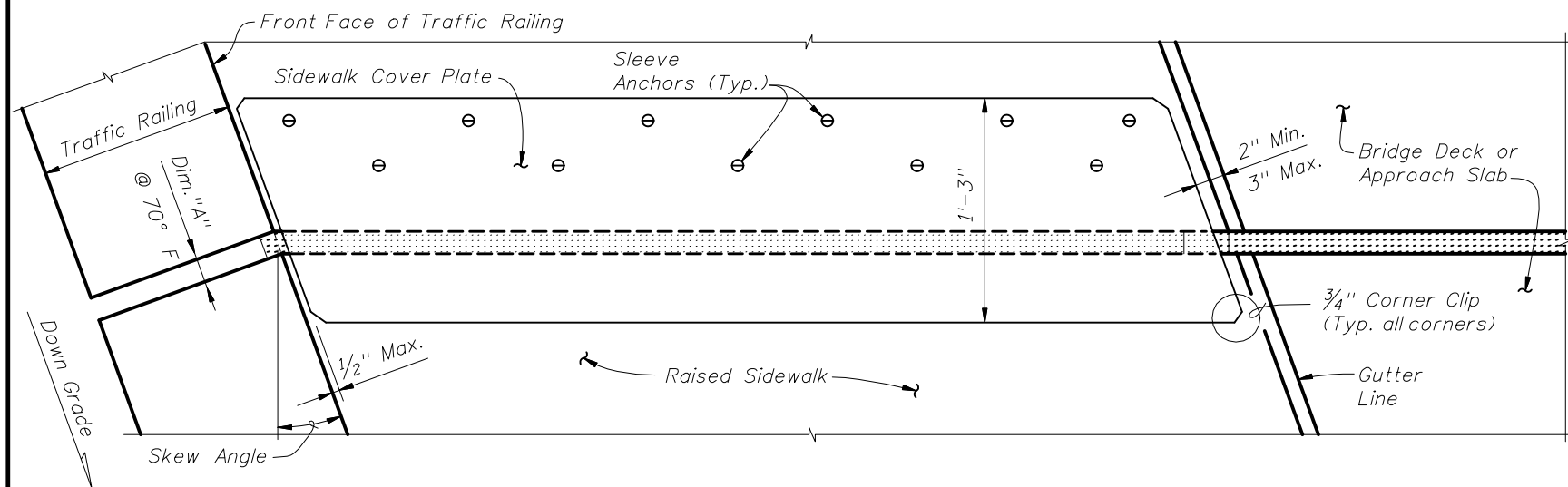

PARTIAL PLAN VIEW OF SKEWED JOINTS

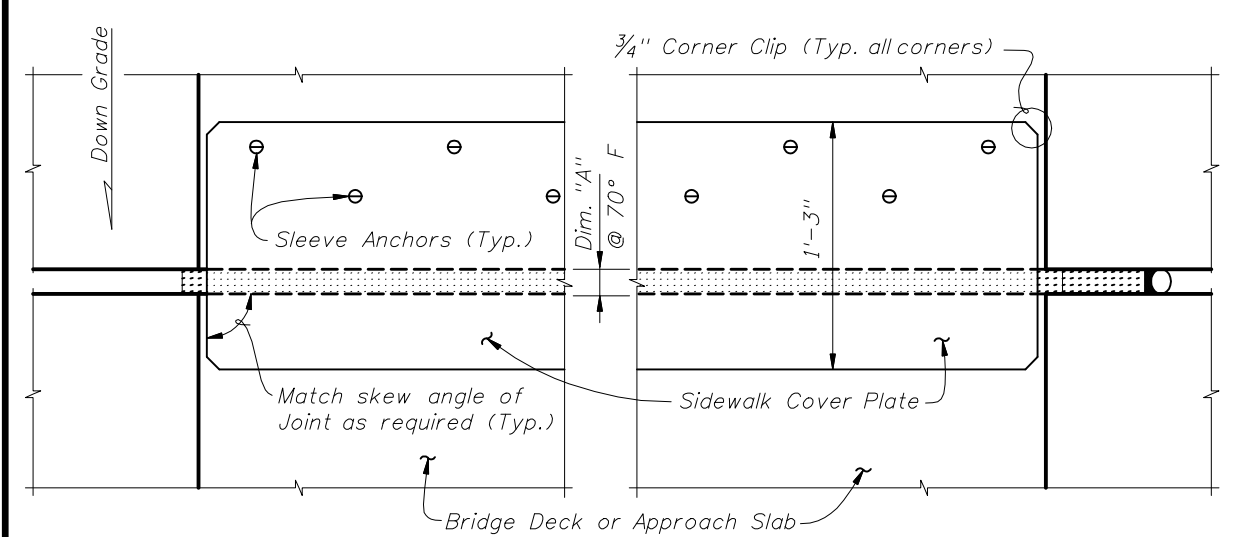

PARTIAL PLAN VIEW

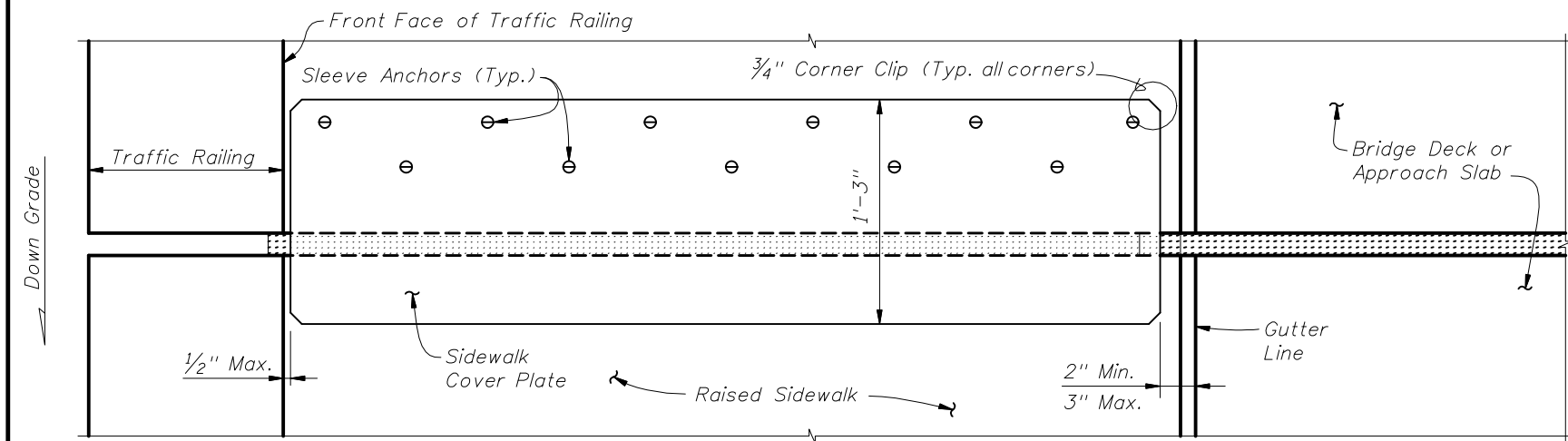

PARTIAL PLAN VIEW OF NON-SKEWED JOINTS

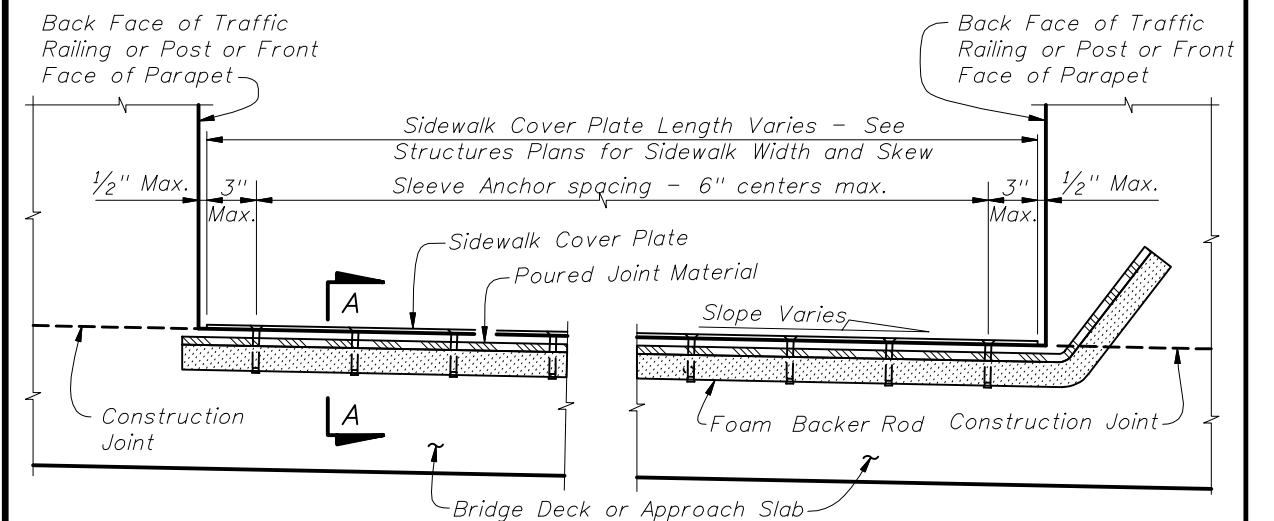

PARTIAL SECTION ALONG Q JOINT

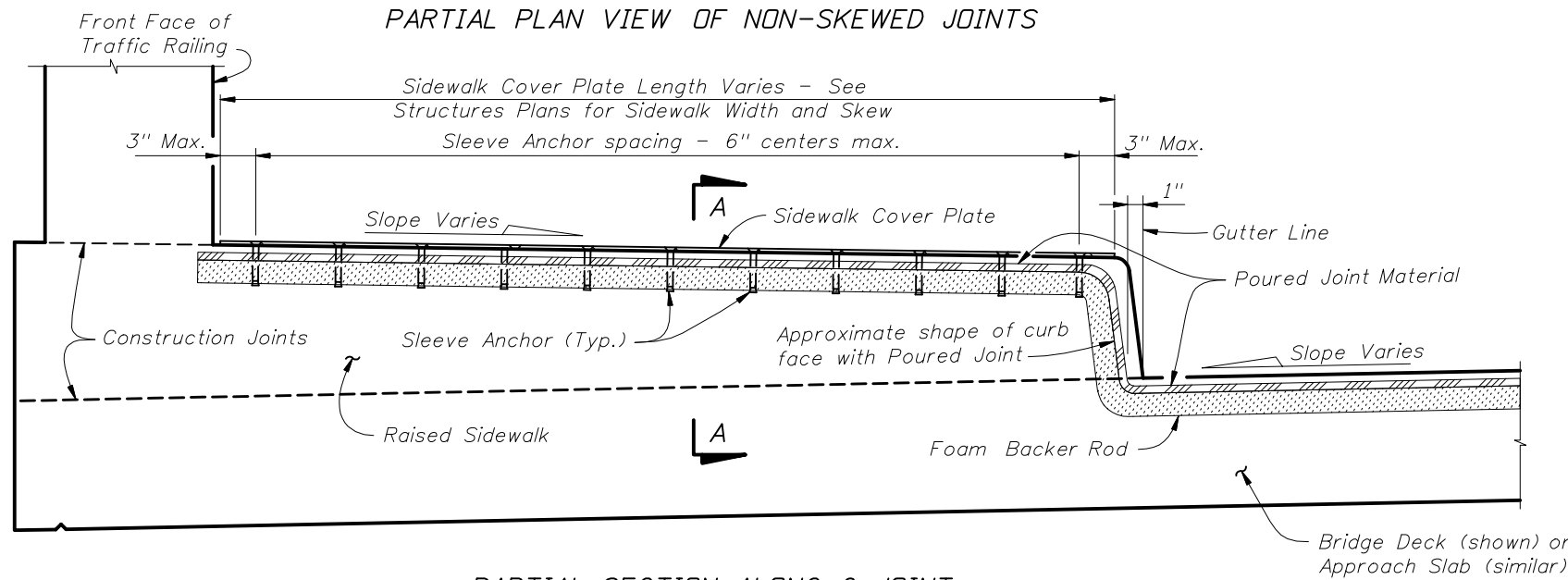

PARTIAL SECTION ALONG Q JOINT

RAISED SIDEWALK DETAIL

FLUSH SIDEWALK DETAIL

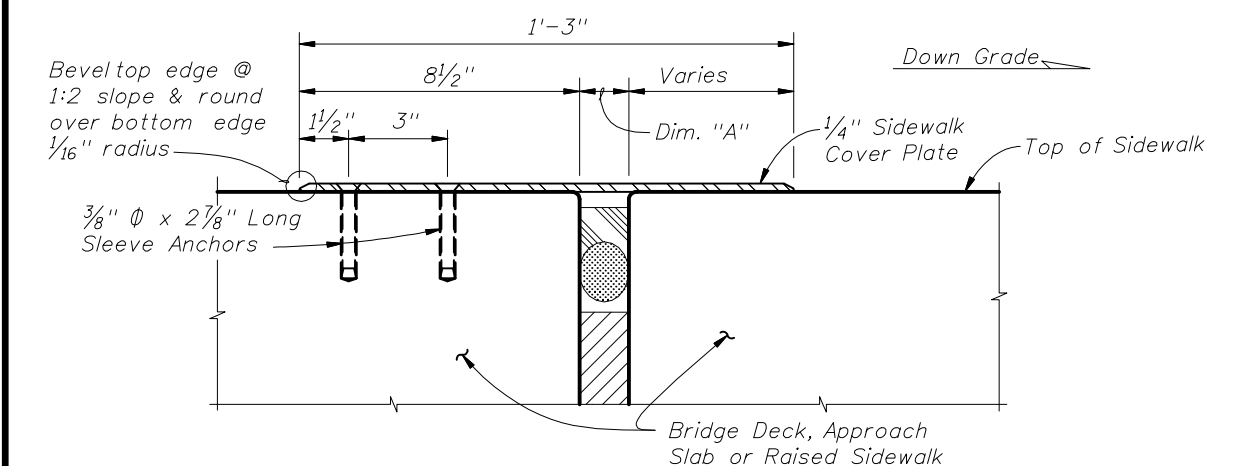

SECTION A-A



2010 FDOT Design Standards

**POURED JOINT WITH BACKER ROD
EXPANSION JOINT SYSTEM**

Last Revision 01/01/09	Sheet No. 2 of 2
Index No. 21110	