

TOP VIEW

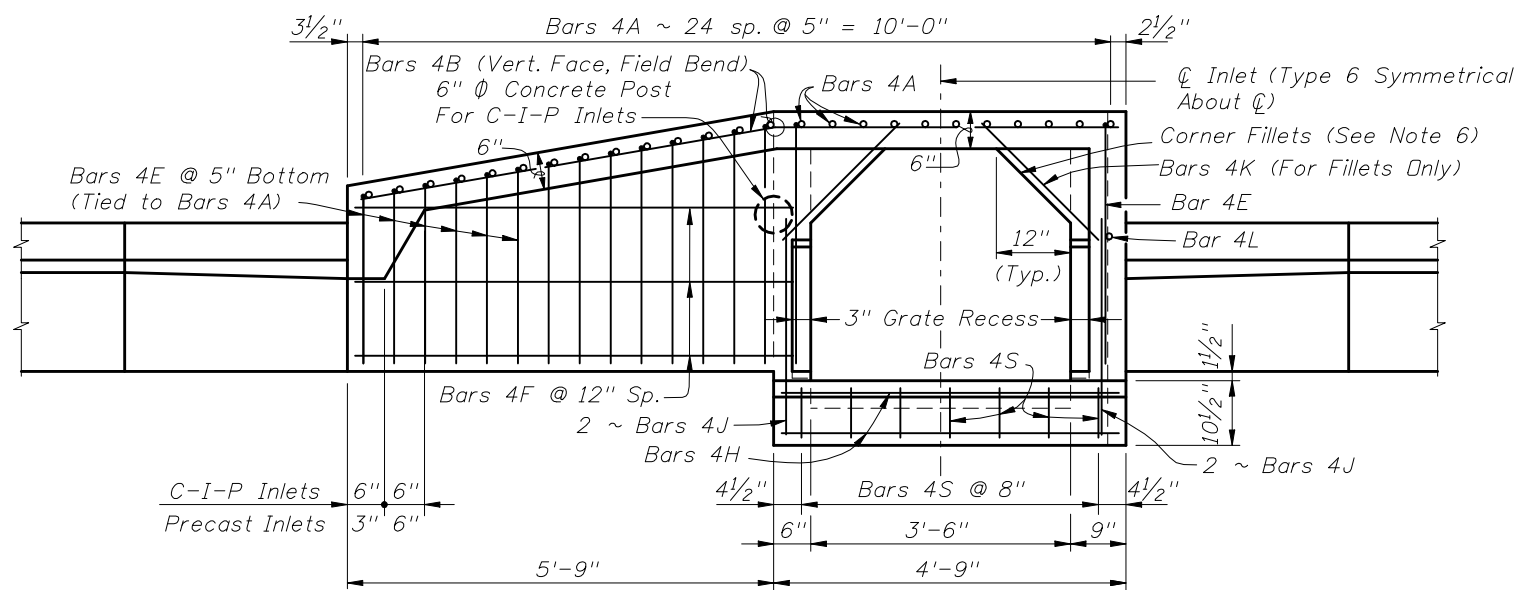

SECTION BB

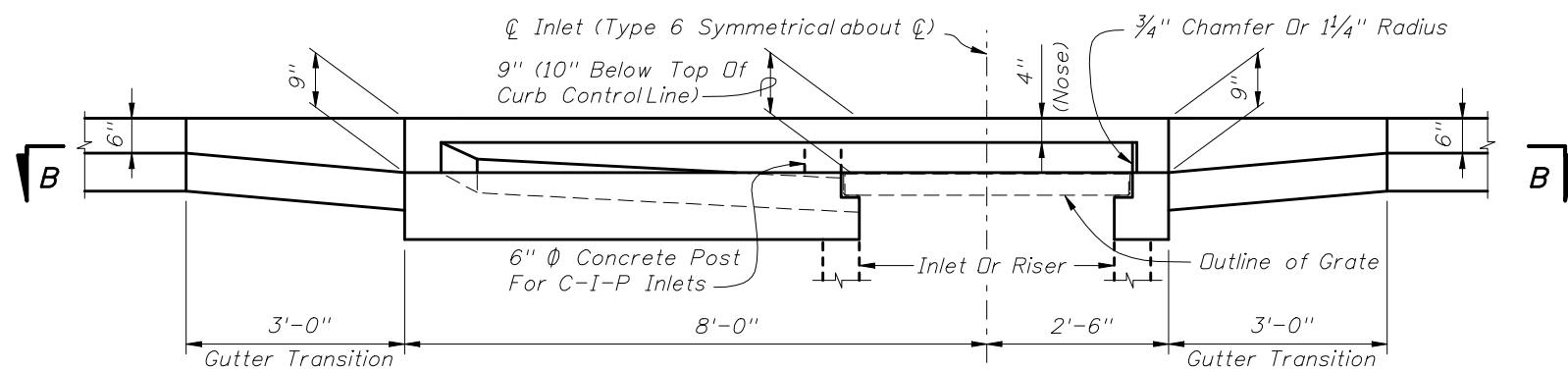

SECTION AA
(At Inlet)

INLET TYPE 5
(Curb Inlet Type 6 Symmetrical With Left Half)

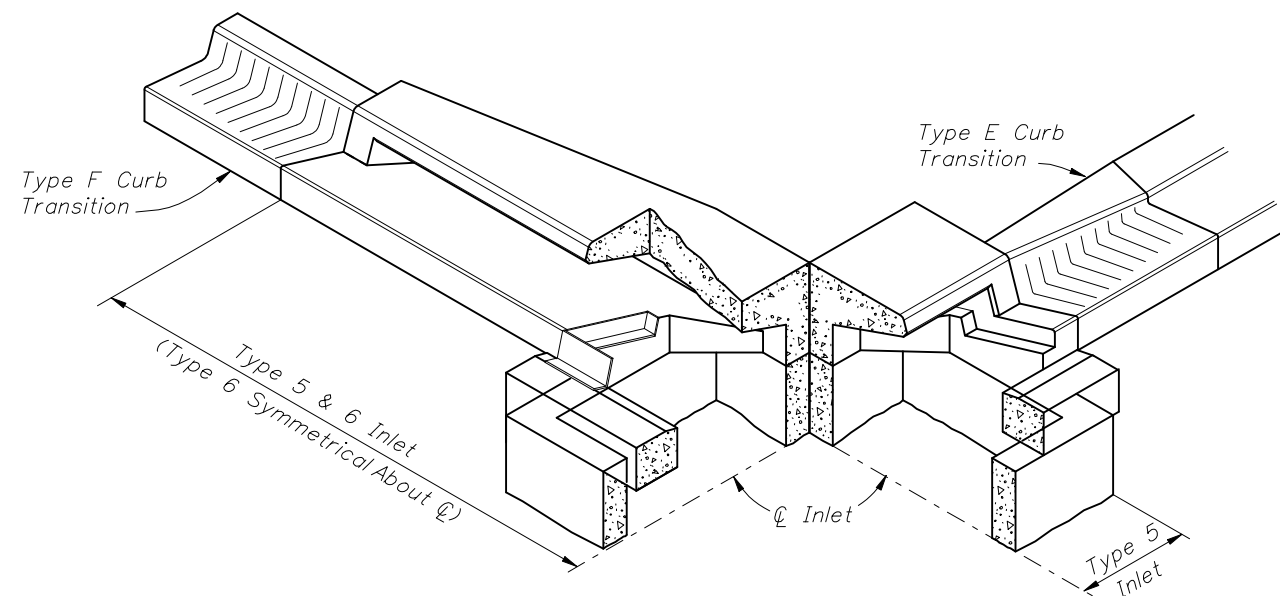

SKETCH SHOWING FRAME SEAT AND THROAT RECESS

GENERAL NOTES

1. The finished grade and slope of the inlet tops are to conform with the finished cross slope and grade of the proposed sidewalk and/or border.
2. For inlets constructed on a curve, refer to the plans to determine the radius, and modify the inlet details accordingly. Bend steel when necessary.
3. All reinforcing steel to be Grade 60 bars with 1 1/4" minimum cover unless otherwise shown, see Sheet 4 for equivalent area Welded Wire Reinforcement details.
4. Inlet tops shall be either cast-in-place or precast concrete. Precast units shall conform to the dimensions shown or in accordance with approved shop drawing's. Request for shop drawing approval shall be directed to the State Drainage Engineer.
5. Concrete meeting the requirements of ASTM C478 (4,000 psi) may be used in lieu of Class II concrete for precast units, manufactured in plants which meet the requirements of Section 449 of the Specifications.
6. Corner fillets are required at inlet opening for precast units or C-I-P units used in conjunction with circular inlet bottoms or skewed rectangular inlet boxes. Finish top of fillets flush with drain throat bottom and match slope.
7. For inlet bottoms see Index No. 200. Inlet tops are to be used with Type P bottoms, or Type J bottoms with 3'-6" square (Type B), 3'-6" or 4' round (Type A) risers or top slab openings.
8. These inlet tops are designed for use with standard curb and gutter Type E and Type F. Locate inlet outside of pedestrian crosswalks. For Type E curb, transition the shape of the curb over the gutter transition length to match the face of the inlet (Type F).
9. See Index No. 201 for supplemental details.
10. All steel used for frame and grate shall meet the requirements of ASTM A36/A36M.
11. Either cast iron grates or steel grates may be used.
12. When Alternate "G" grate is specified in the plans either the cast iron grate and galvanized steel frame or the galvanized steel grate and frame must be used. Grates are to be grouted in accordance with the grouting detail shown on Sheet 5, in lieu of tack welding.
13. Inlet to be paid for under the contract unit price for Inlets (Curb) (Type -), Each.

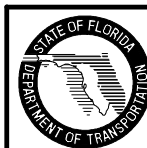

2010 FDOT Design Standards

CURB INLET TOPS
TYPES 5 & 6

Last Revision	Sheet No.
07/01/09	1 of 5
Index No.	
211	

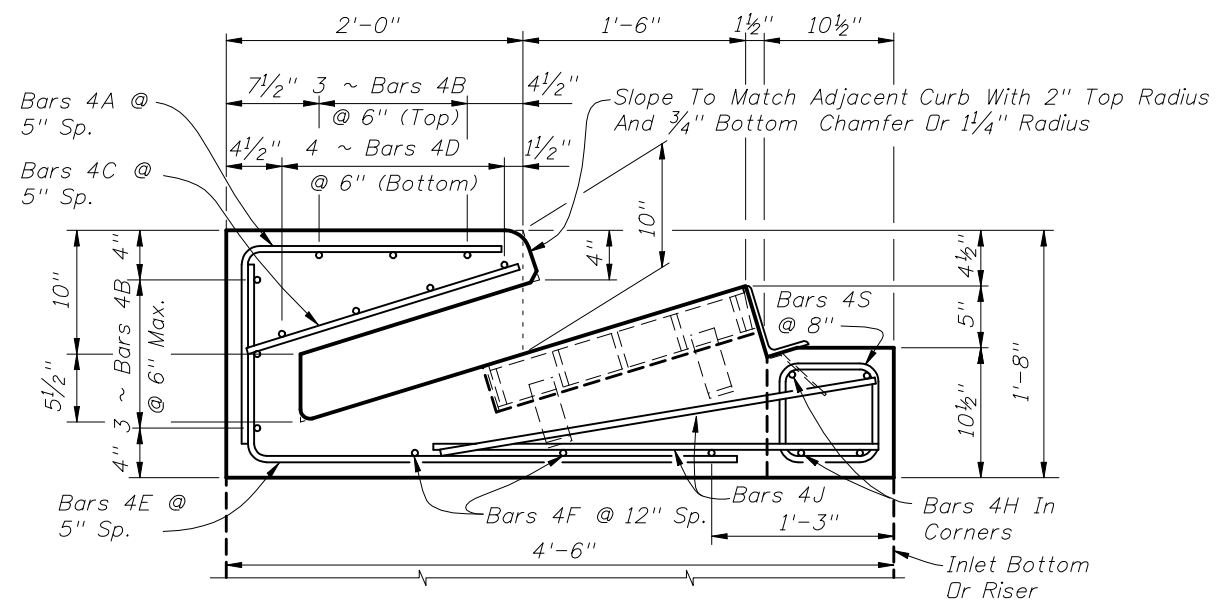

SECTION FF

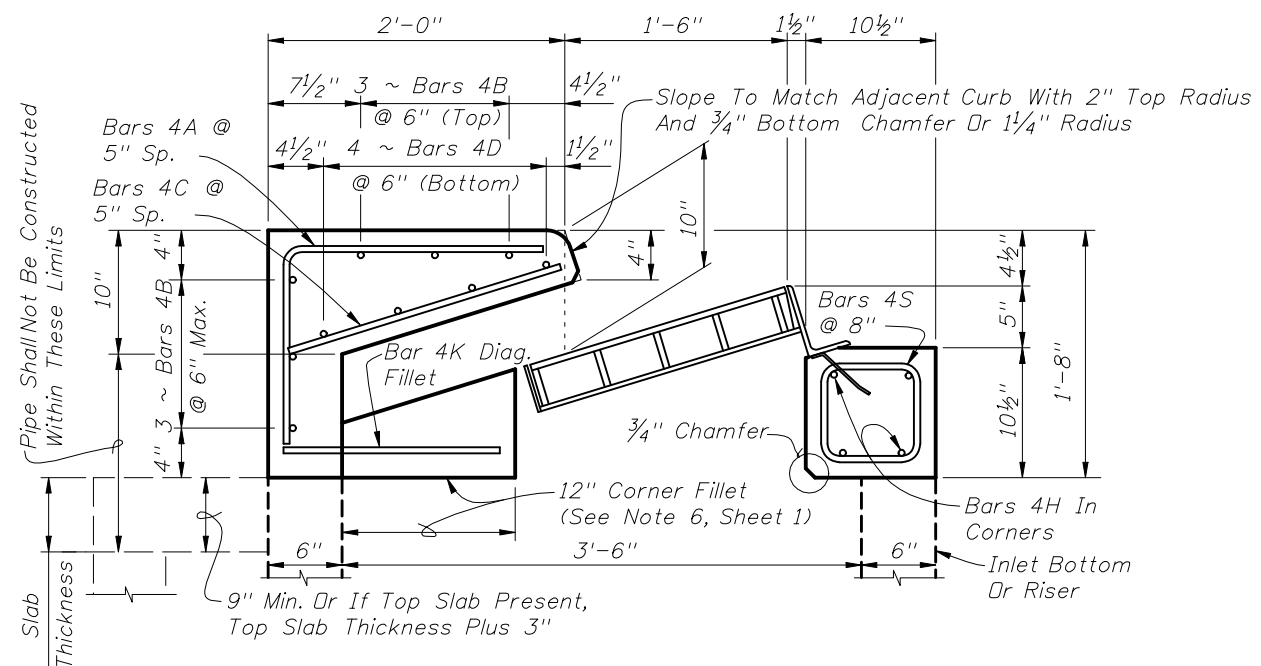

SECTION GG

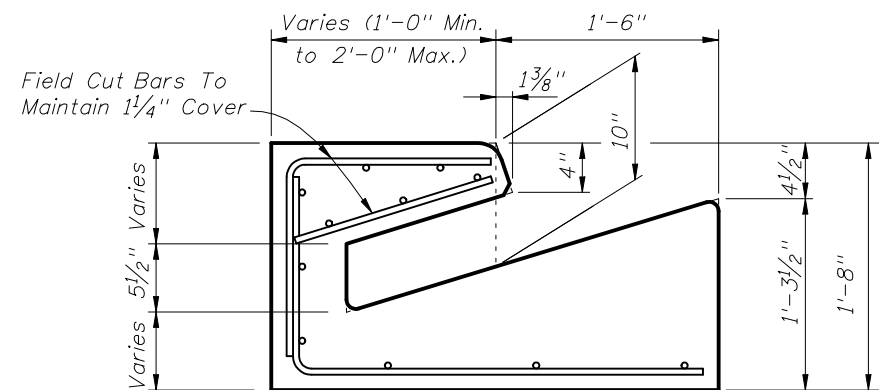

SECTION EE

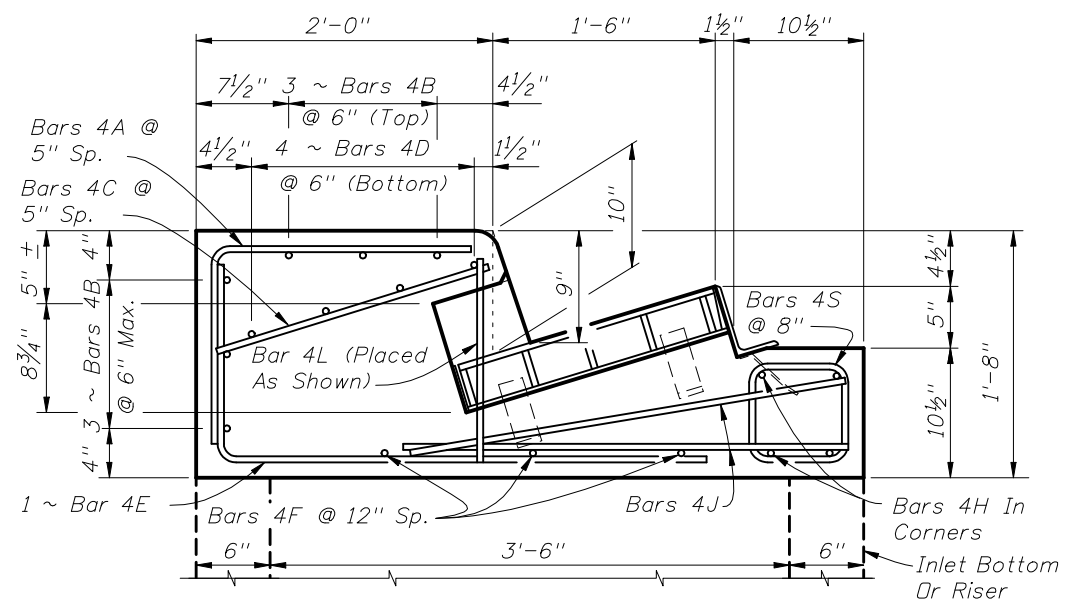

SECTION HH
(Type 5 Inlet Only)

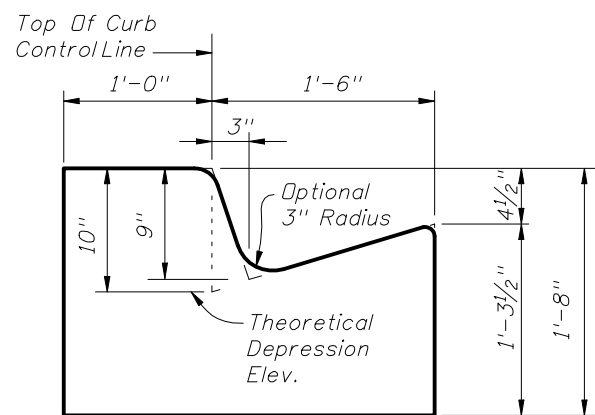

SECTION DD
(End View Of Inlet)

CROSS REFERENCES:
For General Notes See Sheet 1.
For Location Of Sections DD Thru HH See Sheet 1.

PRECAST DETAILS



2010 FDOT Design Standards

CURB INLETS TOPS
TYPES 5 & 6

Last Revision
07/01/09

Sheet No.
2 of 5

Index No.
211

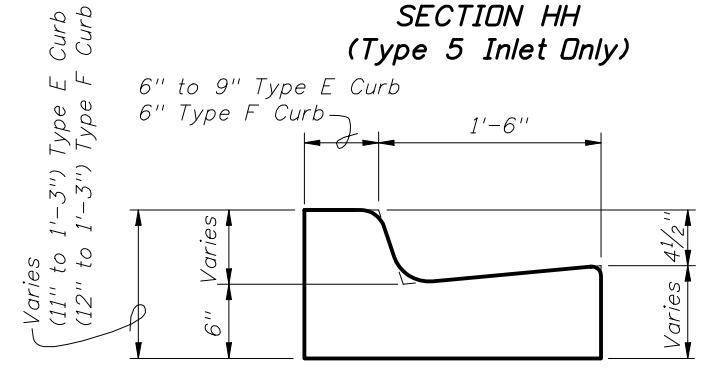
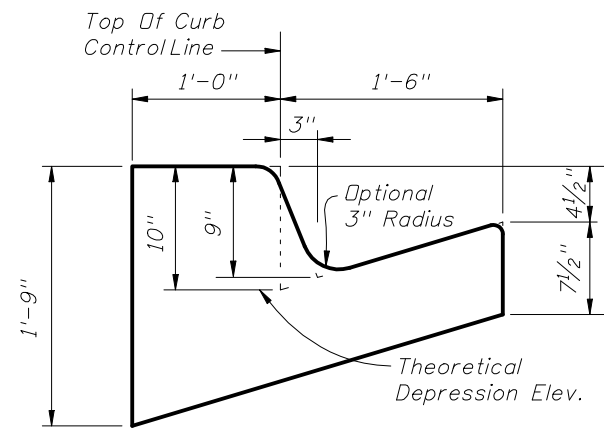
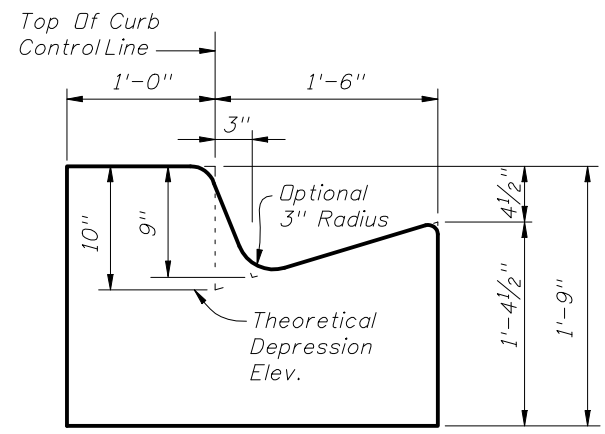
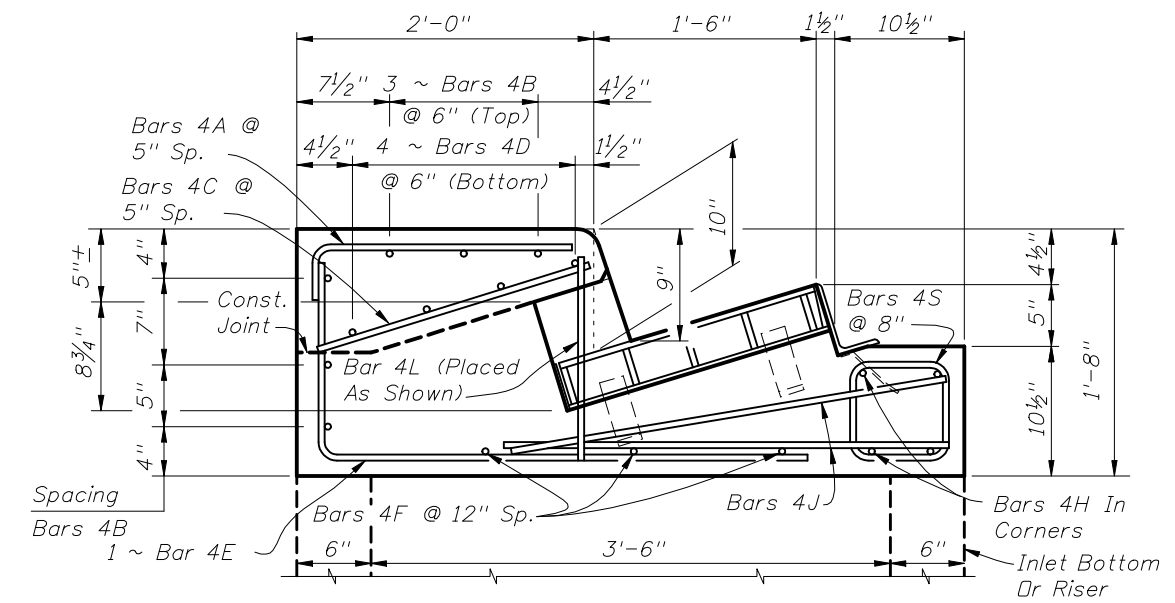
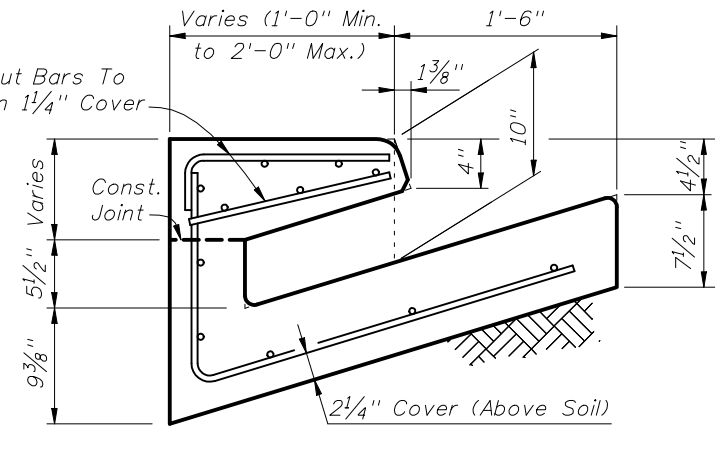
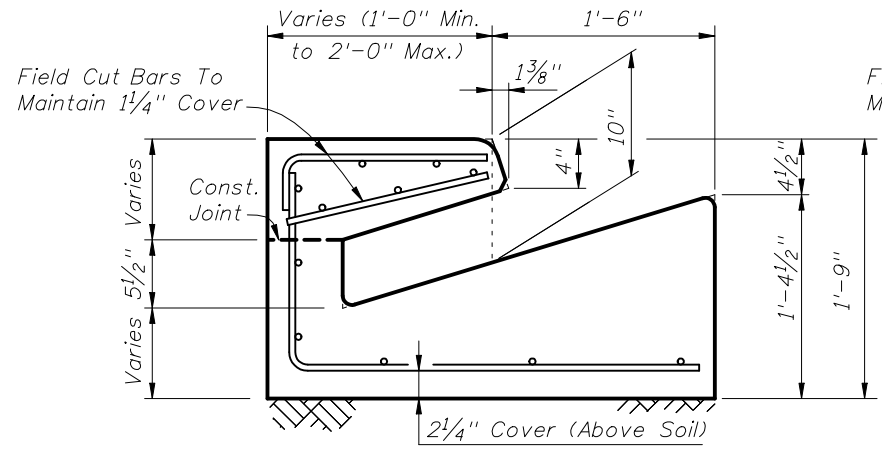
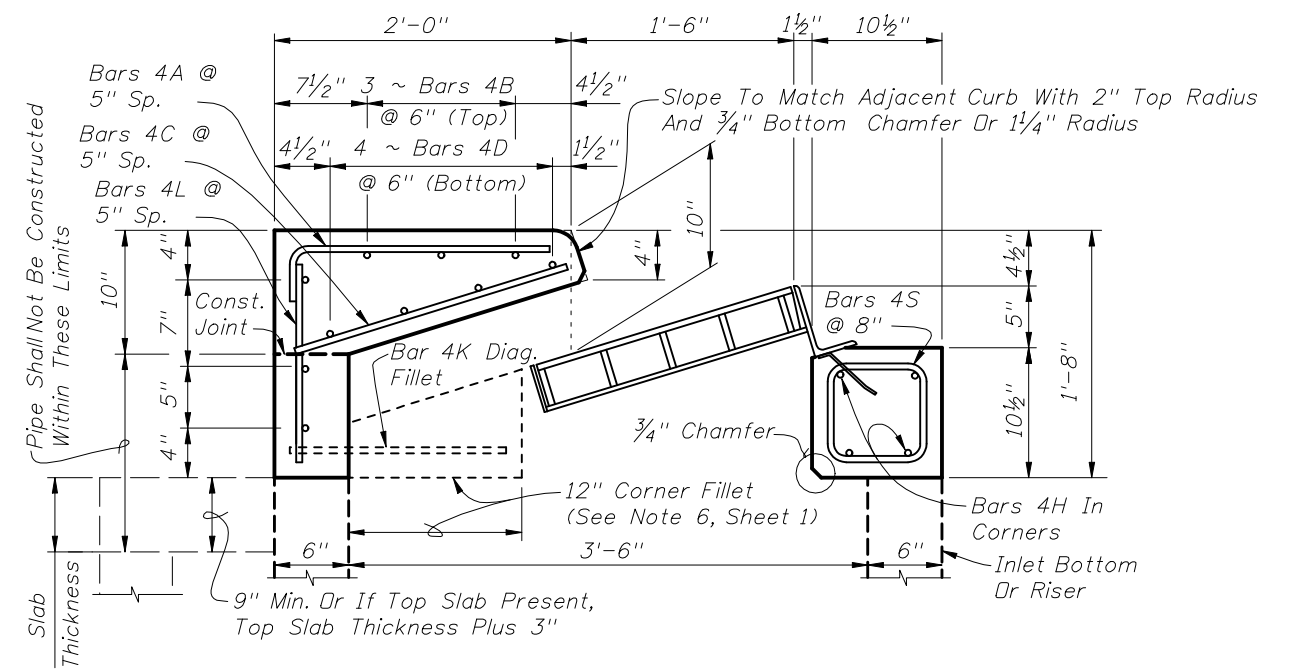
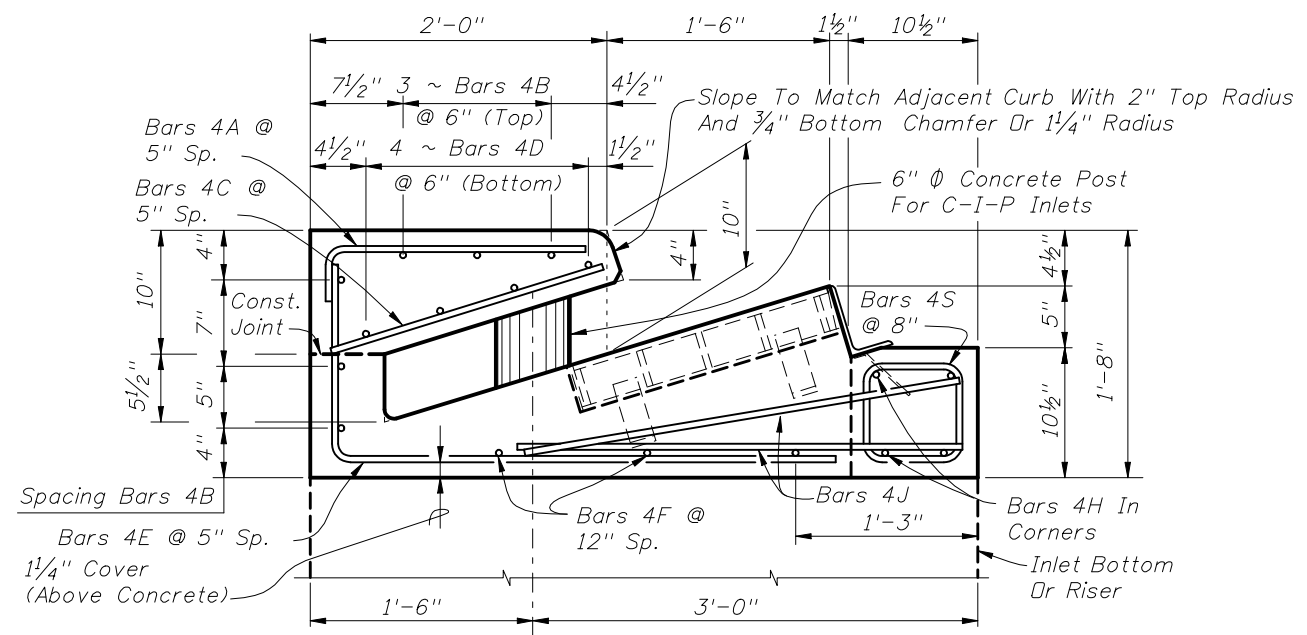

CROSS REFERENCES:
For General Notes See Sheet 1.
For Location Of Sections CC Thru HH See Sheet 1.

CAST-IN-PLACE DETAILS



ALTERNATE REINFORCING STEEL DETAILS FOR WELDED WIRE REINFORCEMENT (WWR)

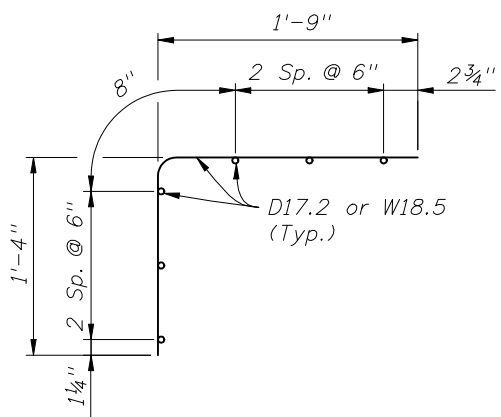

WELDED WIRE REINFORCEMENT
PIECE NO. 1

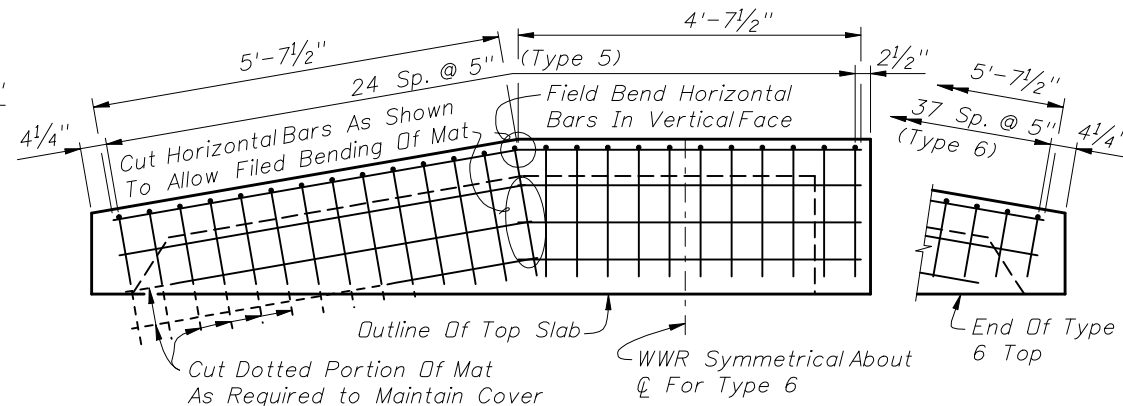

PLACEMENT SCHEMATIC FOR WELDED WIRE
REINFORCEMENT PIECE NO. 1

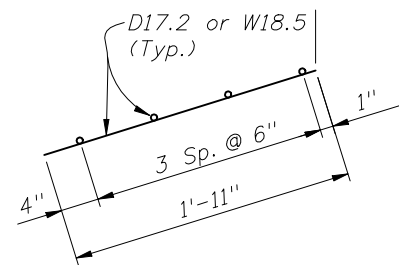

WELDED WIRE REINFORCEMENT
PIECE NO. 2

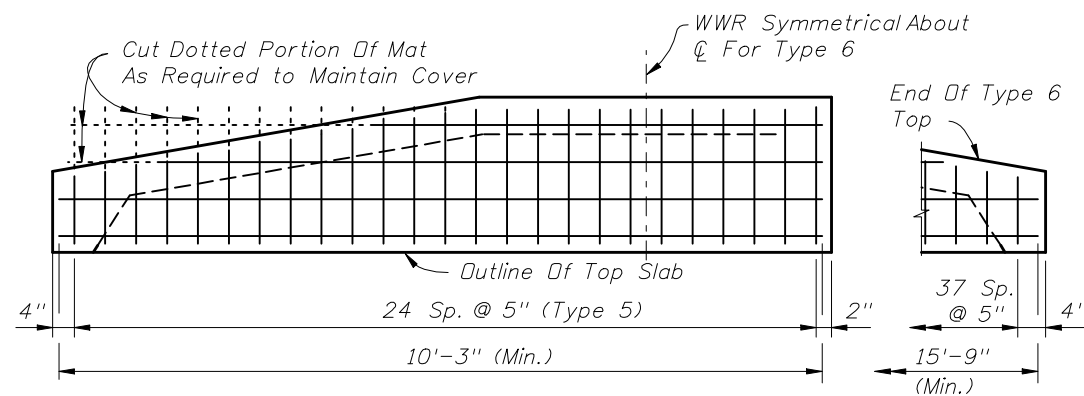

PLACEMENT SCHEMATIC FOR WELDED WIRE
REINFORCEMENT PIECE NO. 2

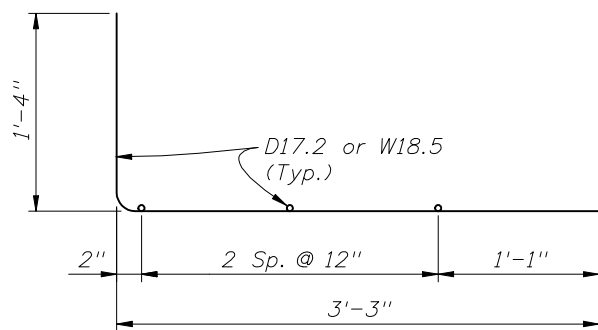

WELDED WIRE REINFORCEMENT
PIECE NO. 3

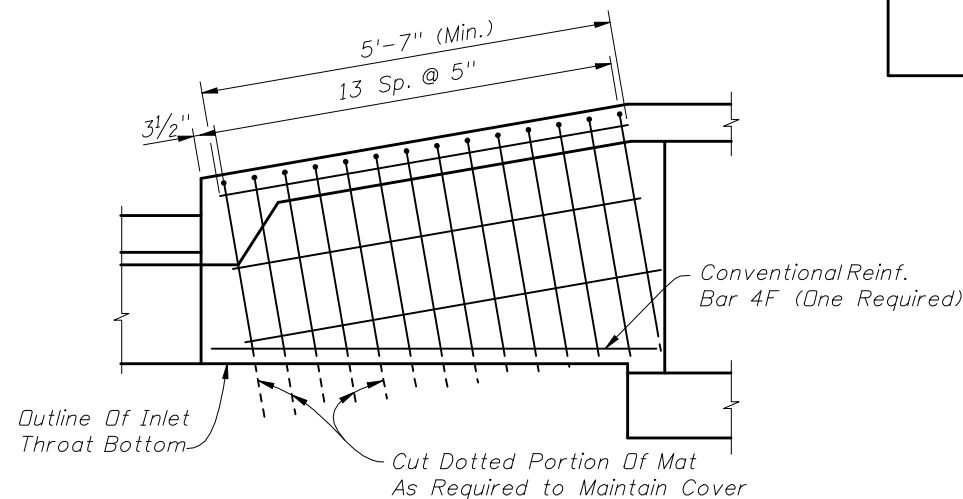

PLACEMENT SCHEMATIC FOR WELDED WIRE
REINFORCEMENT PIECE NO. 3

CONVENTIONAL REINFORCING STEEL BENDING DIAGRAMS

BILL OF REINFORCING STEEL

MARK	SIZE	TYPE 5 INLET		TYPE 6 INLET	
		NO.	LENGTH	NO.	LENGTH
A (Precast)	4	25	3'-1"	38	3'-1"
A (C-I-P)	4	25	2'-1 1/2"	38	2'-1 1/2"
B	4	6	10'-3"	6	15'-9"
C	4	25	11" to 1'-11"	38	11" to 1'-11"
D	4	4	10'-3"	4	15'-9"
E	4	16	4'-7"	30	4'-7"
F	4	3	6'-0"	6	6'-0"
H	4	4	4'-6"	4	4'-6"
J	4	4	3'-0"	4	3'-0"
K (Fillet)	4	2	2'-3"	2	2'-3"
L (Precast)	4	1	1'-4"	0	---
L (C-I-P)	4	10	1'-4"	9	1'-4"
S	4	7	3'-2"	7	3'-2"

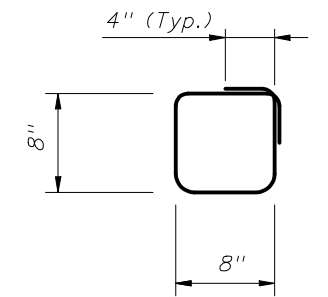

BAR 4S

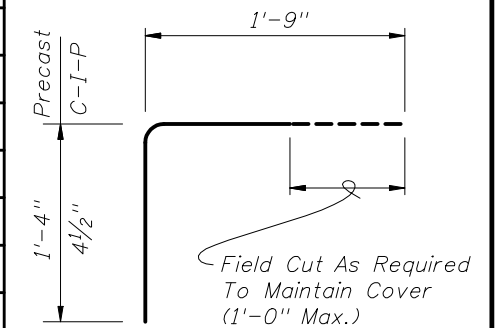

BAR 4A

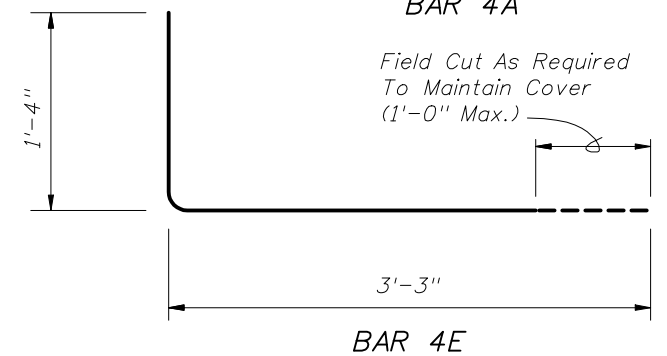

BAR 4E

REINFORCING STEEL NOTES:

1. All bar dimensions in the bending diagrams are out to out.
2. Bars 4A and 4E may be combined into a single bar.
3. Welded Wire Reinforcement shall comply with ASTM A185 or ASTM A497.

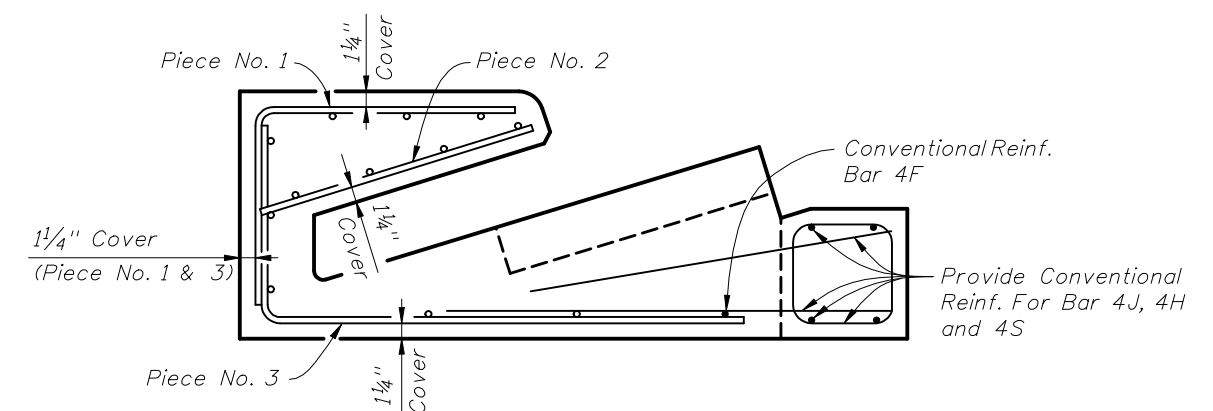

TYPICAL SECTION SHOWING
WELDED WIRE REINFORCEMENT



2010 FDOT Design Standards

CURB INLETS TOPS
TYPES 5 & 6

Last Revision

07/01/09

Sheet No.

4 of 5

Index No.

211

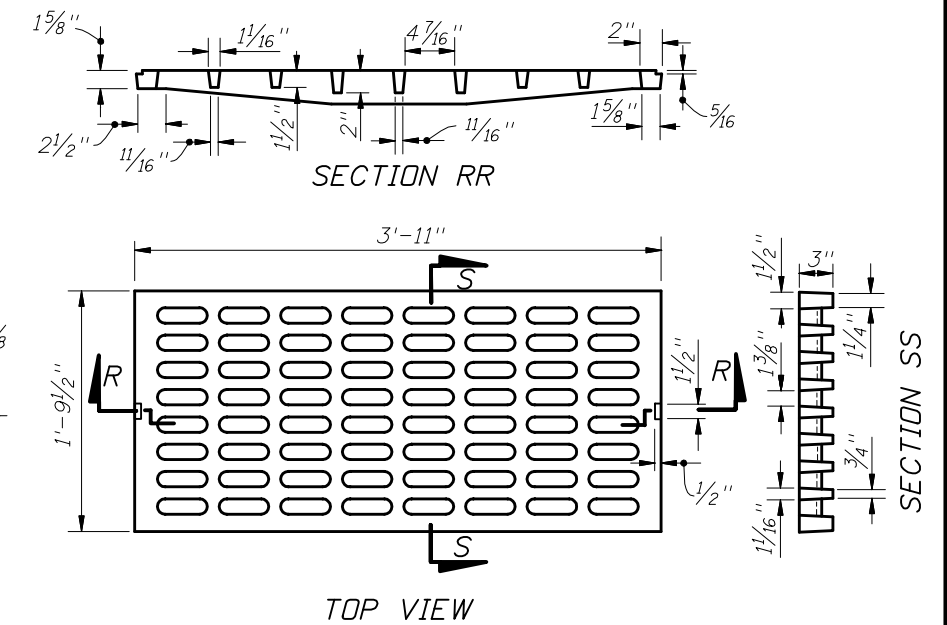
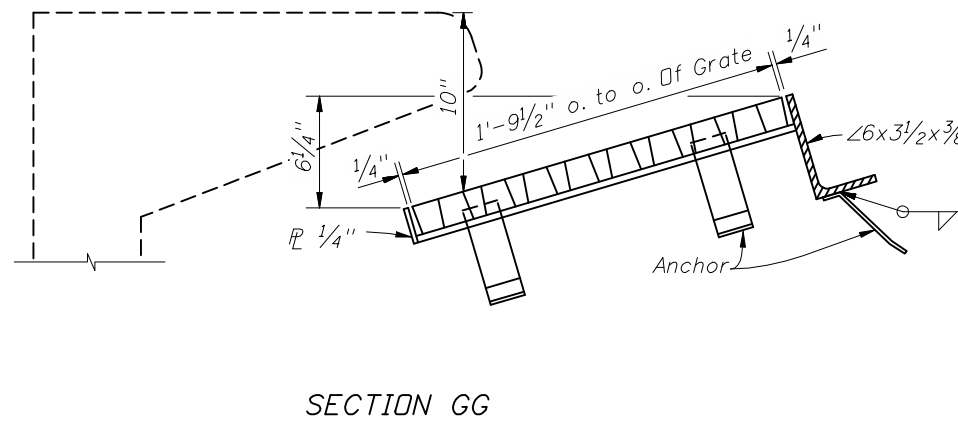
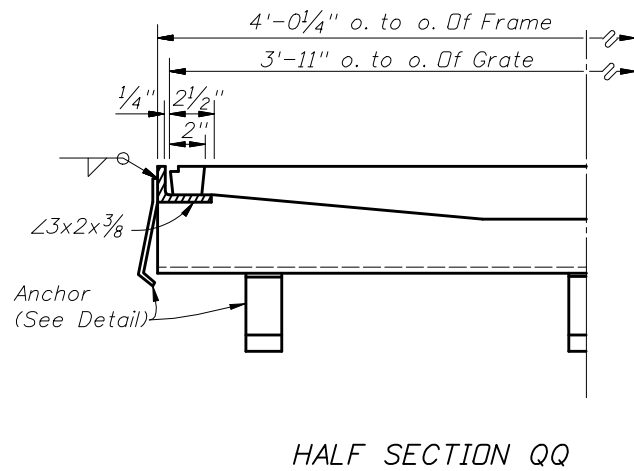
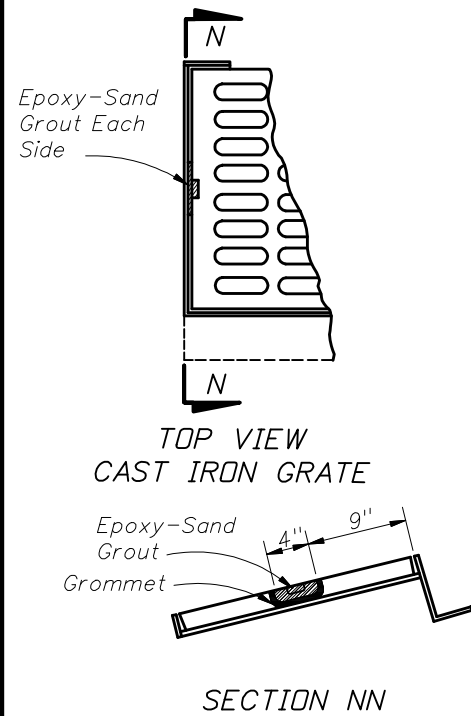

CAST IRON GRATE

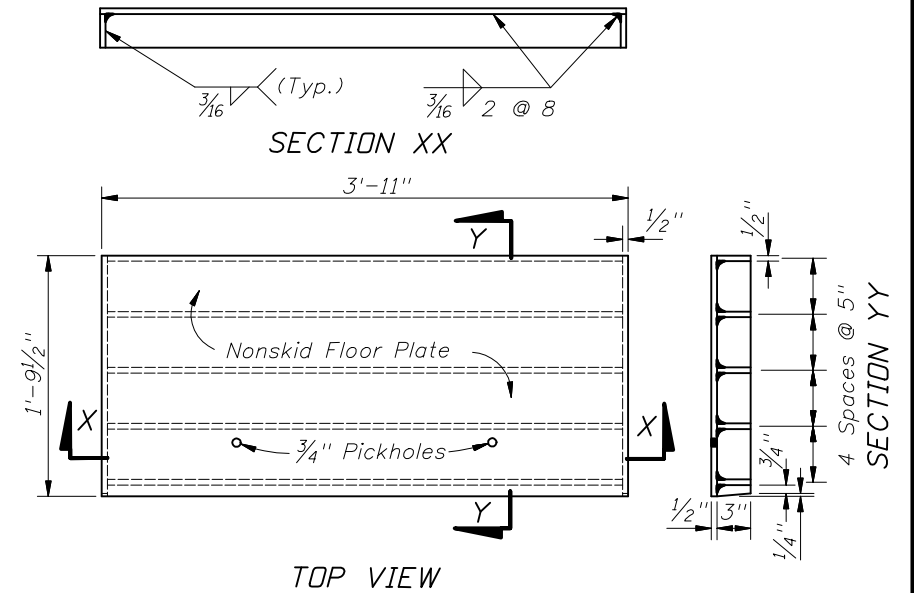
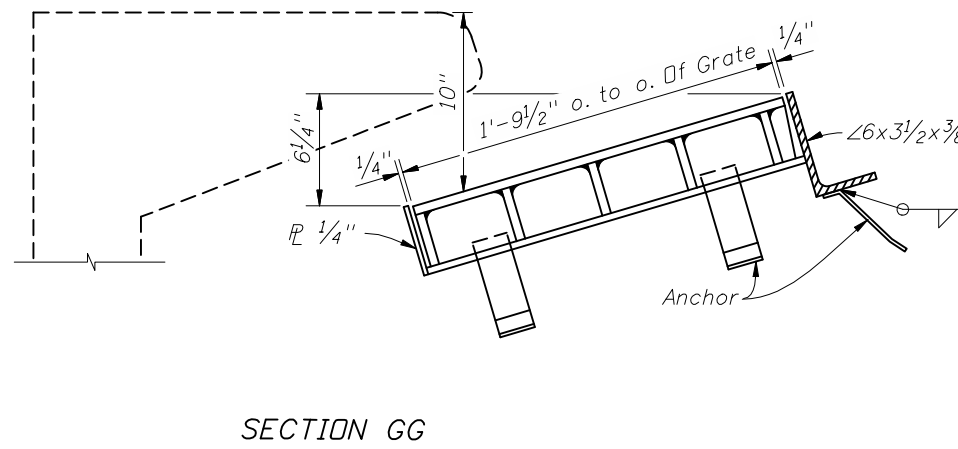
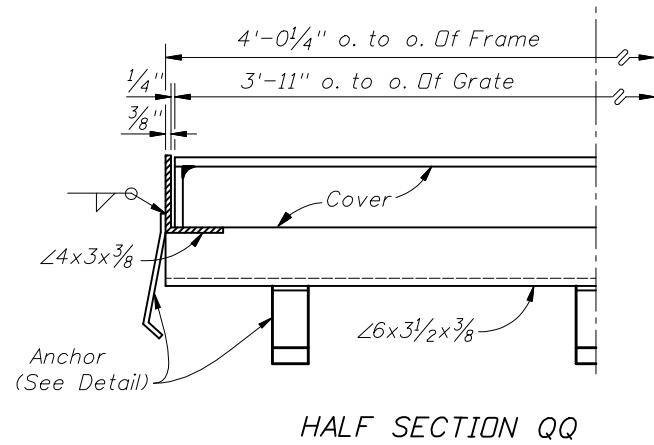
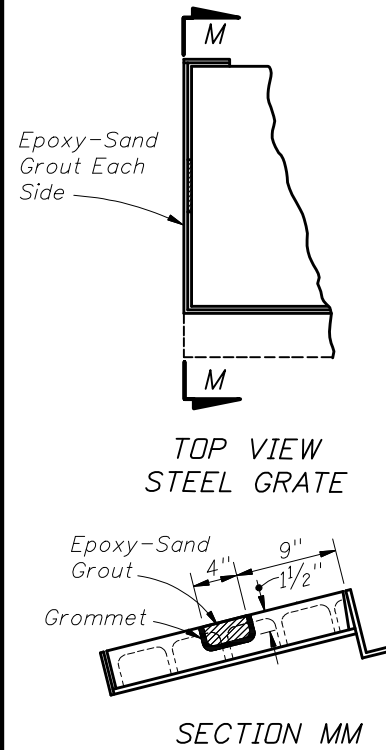

STEEL GRATE

GROUTING DETAILS

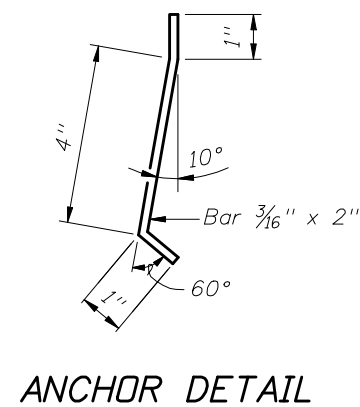
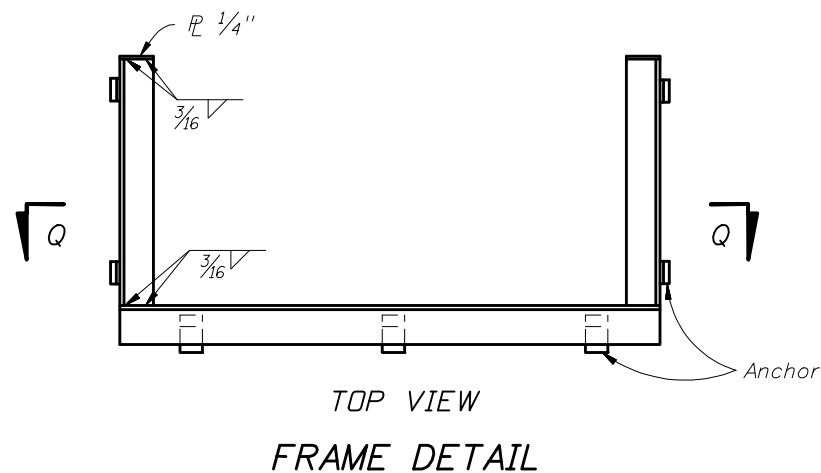

CROSS REFERENCES:
For Location Of Section GG and QQ
See Sheet 1.



2010 FDOT Design Standards

CURB INLET TOPS
TYPES 5 & 6

Last Revision	Sheet No.
07/01/09	5 of 5
Index No.	
211	