

PLAN VIEW (CASE 1)

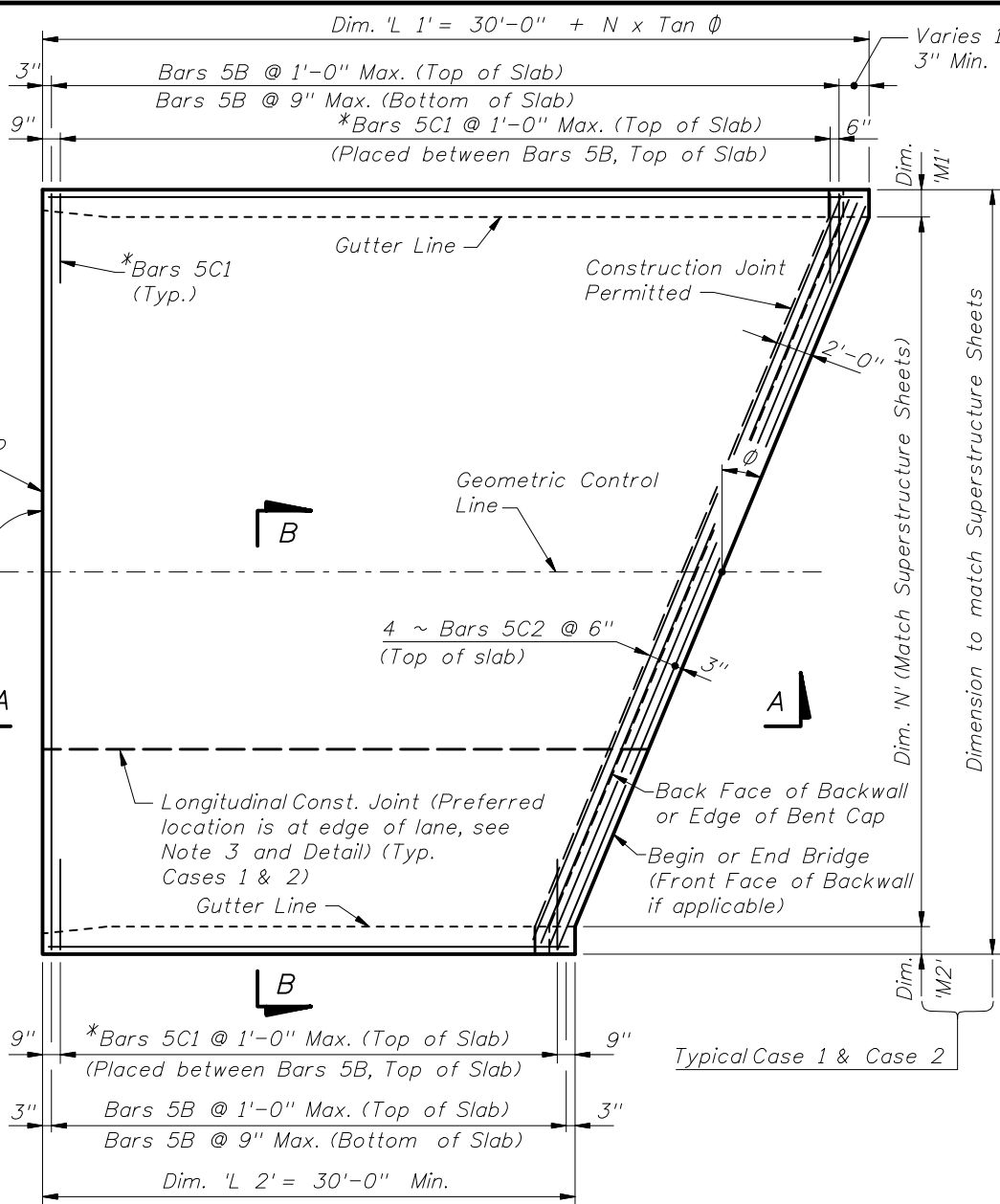

PLAN VIEW (CASE 2)

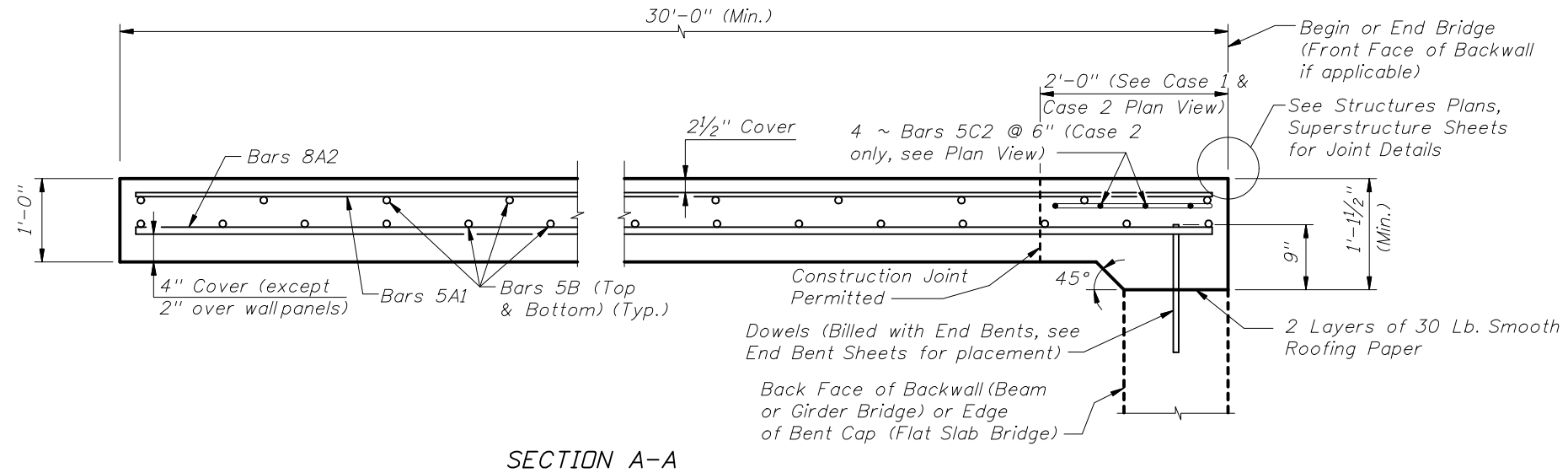

SECTION A-A

GENERAL NOTES

1. SURFACE TREATMENT: Apply a Class 4 Floor Finish (Grooved) to the riding surface from begin or end approach slab joint to begin or end bridge. See Bid Item Notes. Apply a broomed finish to sidewalk areas.
2. UTILITIES: If required, see Structures Plans, Utility Conduit Detail Sheet for details.
3. When a longitudinal construction joint is necessary or allowed by the Engineer, the transverse steel shall be extended as shown in the Longitudinal Construction Joint Detail.
4. The plan view for CASE 1 applies when the skew angle (ϕ) = 0°. Relevant details also apply to CASE 2.
5. The plan view for CASE 2 applies where the skew angle (ϕ) is > 0°. The slab shown represents a skew to the right for an approach slab at begin bridge; approach slab at the end of bridge or a left skew shall be treated similarly. The shown reinforcement shall be utilized, and Dowels shall be provided in accordance with Index Nos. 305 and 306.
6. Railings, parapets and traffic separators shall be provided as shown in Structures Plans. Payment for these items shall be included in the pay item for the required item. Raised sidewalks shall be provided as shown in Structures Plans. Payment shall be included in the pay items for approach slab concrete and reinforcement. Welded Wire Reinforcement for the edge of Approach Slabs on retaining wall is not included in the estimated quantity for reinforcing steel and is considered incidental to the work. Welded Wire Reinforcement shall conform to ASTM A185.
7. PROFILOGRAPH: If profilograph requirements apply, planing may be required. The permitted construction joint shown in Section A-A will facilitate the placement of the expansion joint.
8. Approach slabs shown in Plan View Cases 1 and 2 represent a typical approach slab with edge barriers and no sidewalks. See additional approach slab sheets for sidewalk and other pertinent details.
9. CONCRETE: Provide Class II (Bridge Deck) concrete for approach slabs.

CROSS REFERENCES:

For Section B-B, Longitudinal Construction Joint Detail and Approach Slab Details see Index No. 20910, Sheet 2.

For Estimated Quantities see Structures Plans.

INSTRUCTIONS TO DESIGNER:
 These Indexes shall be supplemented in Structures Plans with additional sheets showing as a minimum a Plan View with geometry and pertinent information not covered by these Indexes e.g., Survey Lines, PGL, Direction of Stationing, Phase Construction Joints, Raised Sidewalks and any other information necessary to accurately complete detailing of the Approach Slabs. Approach Slab Finish Grade Elevations shall be included with the Bridge Finish Grade Elevations in the Structures Plans.
 All Reinforcing bars are to be shown in the Reinforcing Steel List as straight bars (Types 1 and 2). Bars 5C are 5'-0" long.

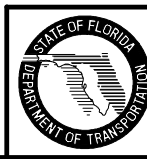

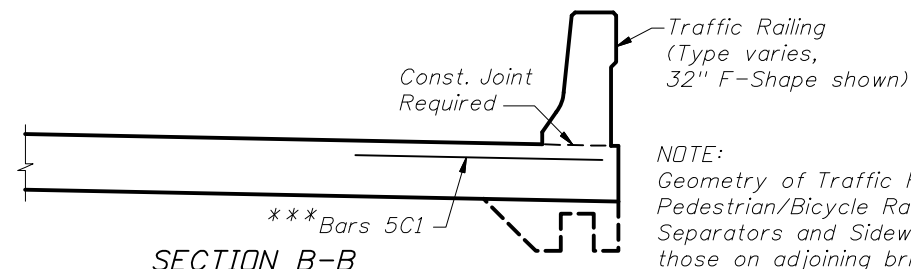

SECTION B-B
STANDARD APPROACH SLAB

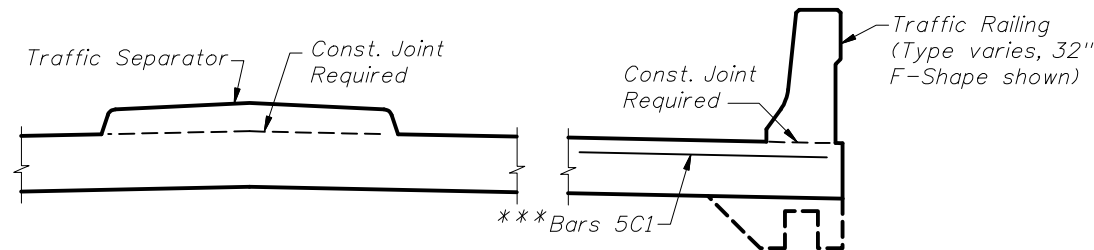

SECTION B-B
APPROACH SLAB WITH TRAFFIC SEPARATOR

NOTE: Bars 5C are required as shown when either the 32" or 42" F-Shape Traffic Railing or the Traffic Railing/Sound Barrier are used at the edge of the Approach Slab.

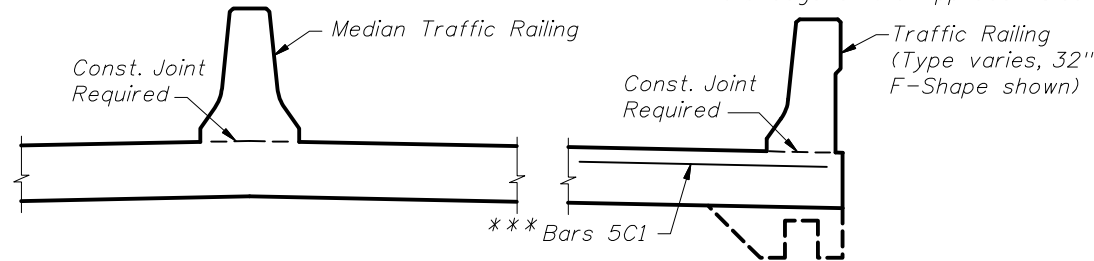

SECTION B-B
APPROACH SLAB WITH MEDIAN TRAFFIC RAILING

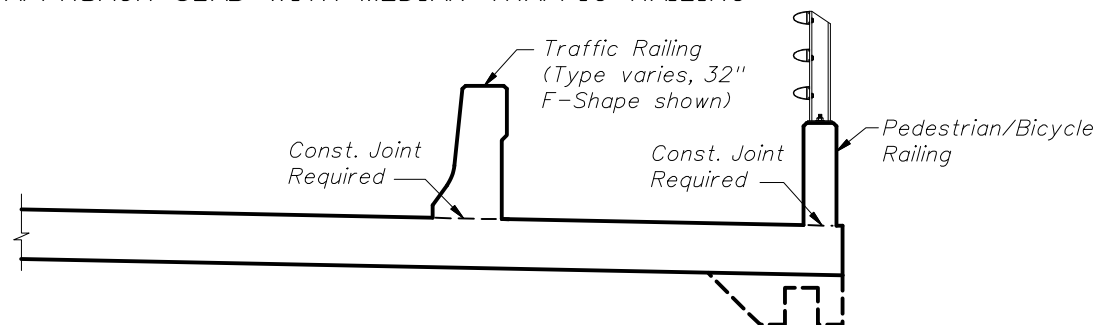

SECTION B-B
APPROACH SLAB WITH SIDEWALK

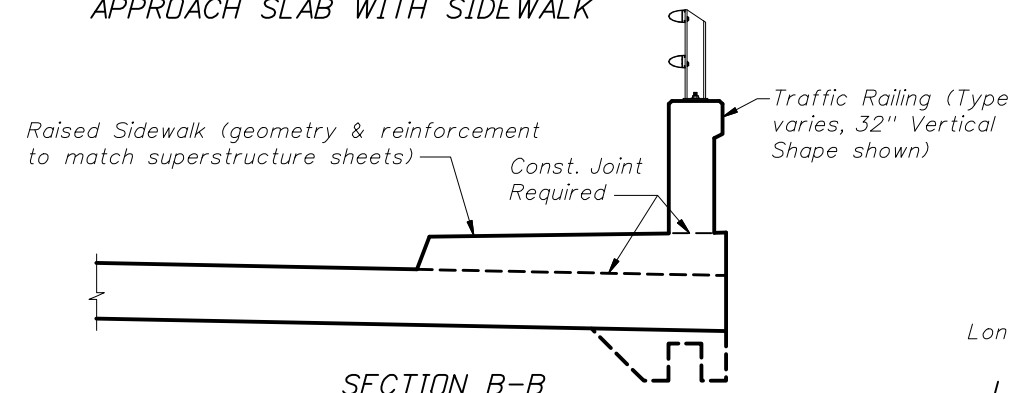

SECTION B-B
APPROACH SLAB WITH RAISED SIDEWALK

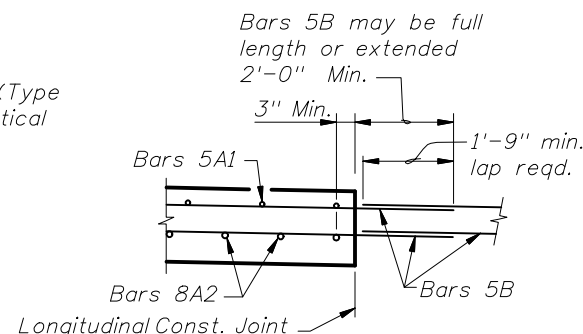

LONGITUDINAL CONSTRUCTION
JOINT DETAIL

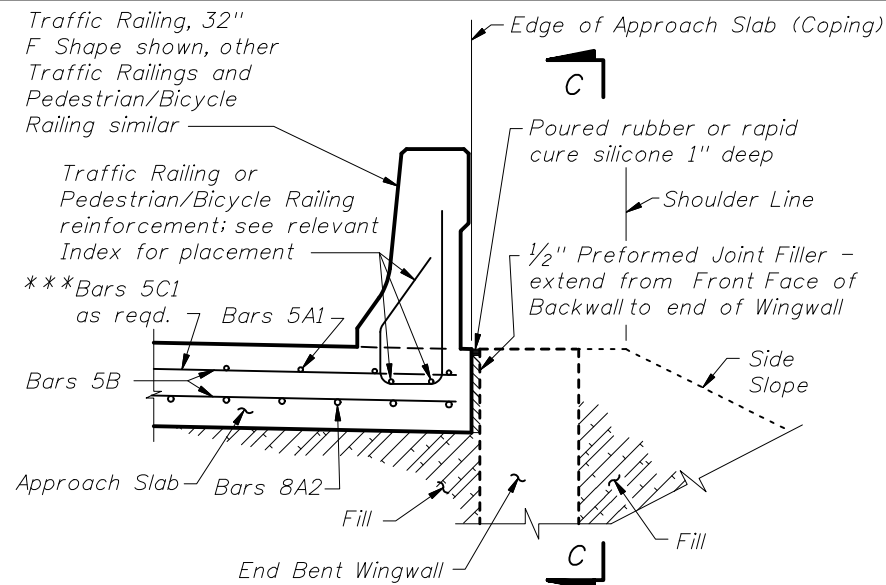

SECTION THRU APPROACH SLAB
AND END BENT WINGWALL

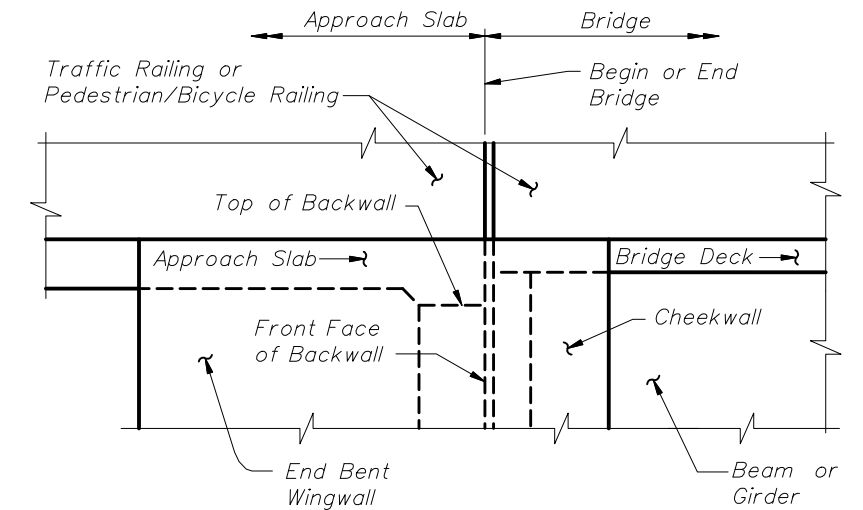

VIEW C-C AT BEGIN OR END BRIDGE (BEAM
BRIDGE SHOWN, FLAT SLAB BRIDGE SIMILAR)

APPROACH SLAB WITH WINGWALL DETAILS

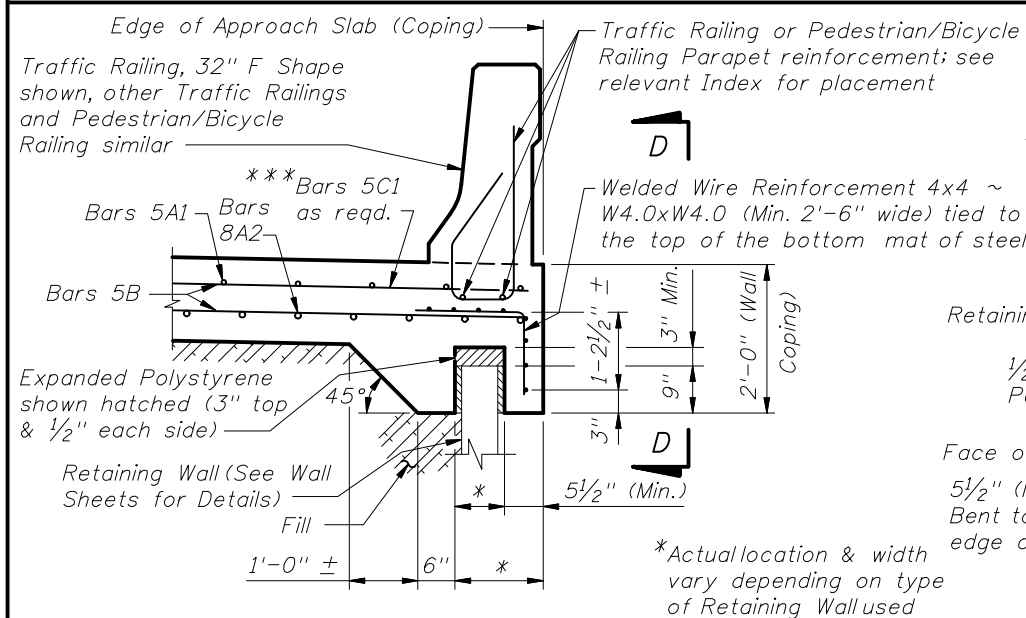

SECTION THRU APPROACH SLAB
AND RETAINING WALL

*Actual location & width vary depending on type of Retaining Wall used

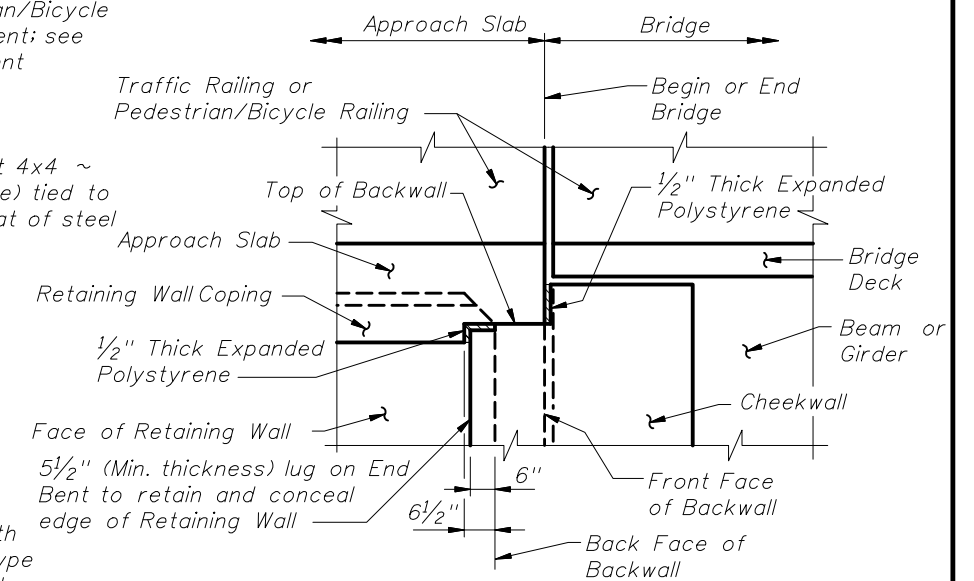

VIEW D-D AT BEGIN OR END BRIDGE (BEAM
BRIDGE SHOWN, FLAT SLAB BRIDGE SIMILAR)

APPROACH SLAB WITH RETAINING WALL DETAILS

CROSS REFERENCES:

For location of Section B-B and Longitudinal Construction Joint Detail see Index No. 20910, Sheet 1.



2010 FDOT Design Standards

APPROACH SLABS
(RIGID PAVEMENT APPROACHES)

Last Revision	Sheet No.
01/01/08	2 of 2
Index No.	
20910	