

** See Note No. 4 on Index No. 20601

ALTERNATE STRAND PATTERNS

- 16 ~ 0.6" Φ , Grade 270 LRS, at 44 kips
- 20 ~ 1/2" Φ , Grade 270 (Spec) LRS, at 34.0 kips
- 20 ~ 9/16" Φ , Grade 270 SR, at 39.0 kips
- 20 ~ 9/16" Φ , Grade 270 (Spec) SR, at 37.1 kips
- 24 ~ 1/2" Φ , Grade 270 LRS, at 31.0 kips
- 24 ~ 1/2" Φ , Grade 270 (Spec) SR, at 31.6 kips

NOTE:
Any of the given Alternate Strand Patterns may be utilized.
The strands shall be located as follows:
Place one strand at each corner and place the remaining strands equally spaced between the corner strands.
The total strand pattern shall be concentric with the nominal concrete section of the pile.

NOTE:
Work this Index with Index No. 20600 - Notes and Details for Square Prestressed Concrete Piles and Index No. 20601 - Square Prestressed Concrete Pile Splices.

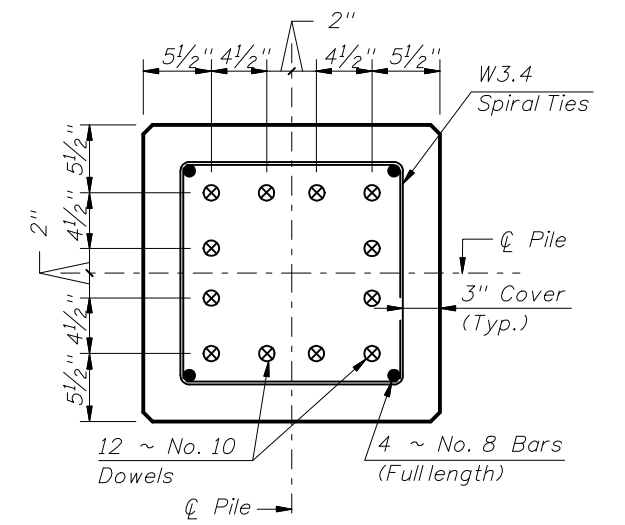
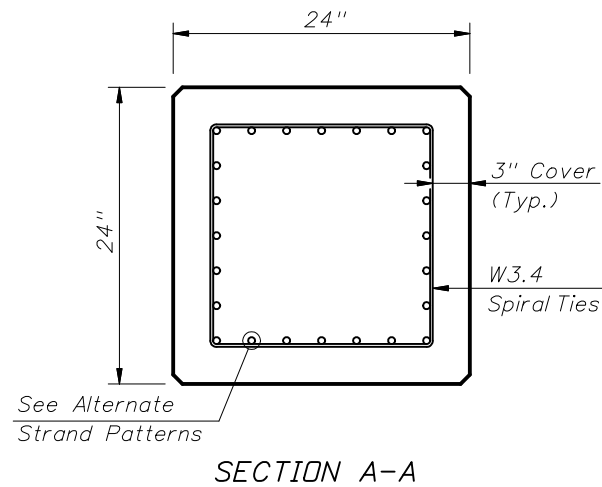

(See Nondrivable Unforeseen Reinforced Precast Pile Splice Detail)

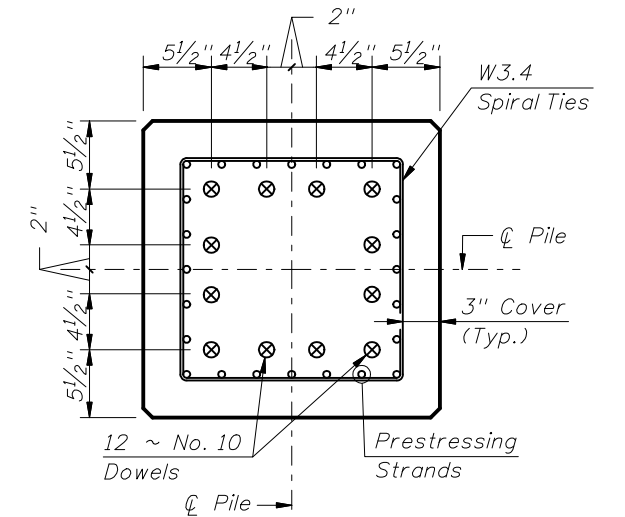

(See Drivable Prestressed Precast Pile Splice Detail)

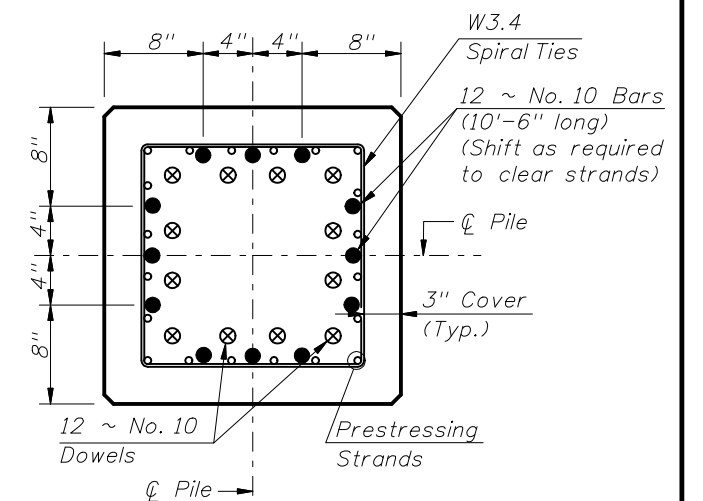

(See Drivable Preplanned Pile Splice Detail)

