

** See Note No. 4 on Index No. 20601

ALTERNATE STRAND PATTERNS

- 12 ~ 0.6" Φ , Grade 270 LRS, at 44 kips
- 16 ~ 1/2" Φ , Grade 270 LRS, at 31.0 kips
- 16 ~ 1/2" Φ , Grade 270 (Spec) SR, at 34.0 kips
- 20 ~ 1/2" Φ , Grade 270 SR, at 26.5 kips
- 24 ~ 7/16" Φ , Grade 270 LRS, at 21.7 kips
- 24 ~ 7/16" Φ , Grade 270 SR, at 21.7 kips

NOTE:
Any of the given Alternate Strand Patterns may be utilized.
The strands shall be located as follows:
Place one strand at each corner and place the remaining strands equally spaced between the corner strands.
The total strand pattern shall be concentric with the nominal concrete section of the pile.

NOTE:
Work this Index with Index No. 20600 - Notes and Details for Square Prestressed Concrete Piles and Index No. 20601 - Square Prestressed Concrete Pile Splices.

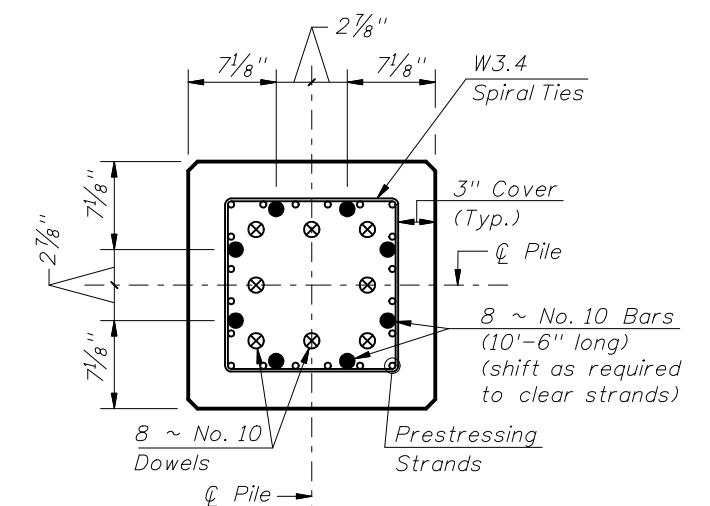
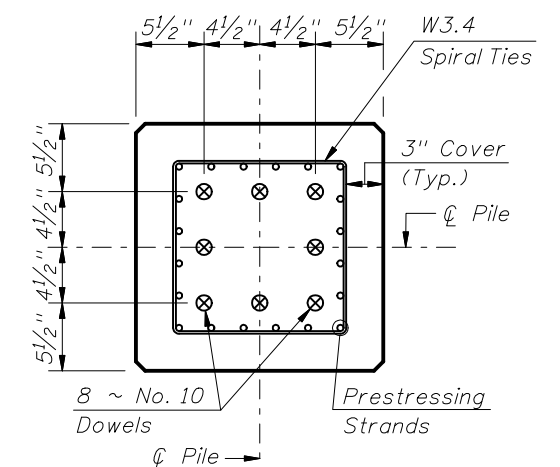
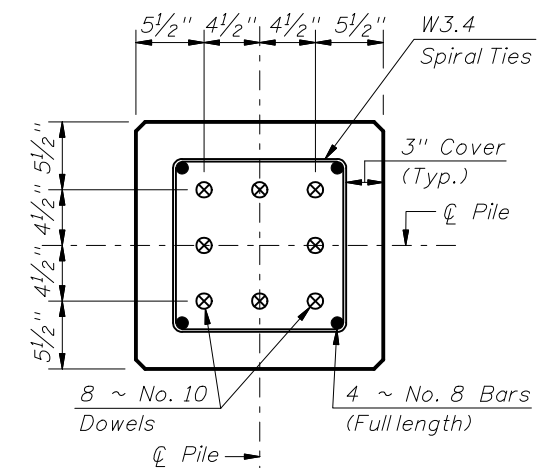
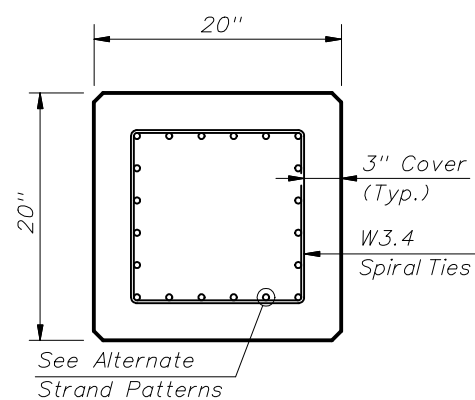

PILE SPLICE REINFORCEMENT DETAILS



2010 FDOT Design Standards

20" SQUARE PRESTRESSED CONCRETE PILE

Last Revision 07/01/05 Sheet No. 1 of 1

Index No. 20620