

# DESIGN STANDARDS

FOR DESIGN, CONSTRUCTION, MAINTENANCE AND UTILITY  
OPERATIONS ON THE STATE HIGHWAY SYSTEM

**2010**

**TOPIC NO. 625-010-003**

Approved For Use On Federal Aid Projects

  
For Martin Knopp, Division Administrator

State of Florida, Department Of Transportation  
Roadway Design Office  
Mail Station 32  
605 Suwannee Street  
Tallahassee, Florida 32399-0450

### NOTICE

*These Design Standards are intended to support the various engineering obligations for designing, constructing, inspecting, maintaining and monitoring the highways, roads and streets on the State Highway System. They are prepared to encourage uniform application of designs and standard details in the preparation of project plans. These Standards may be adopted by other authorities for use on projects under their jurisdiction.*

*It is the responsibility of the Design Engineer of Record using these Standards to determine the fitness for a particular use of each standard in the design of a project. The inappropriate use of and adherence to these standards does not exempt the engineer from the professional responsibility of developing an appropriate design.*

### PATENTED DEVICES, MATERIALS AND PROCESSES

*The use of any design, method, process, material or device either expressed or implied by these standards that are covered by patent, copyright, or proprietary privilege is the sole responsibility of the user. Any infringement on the rights of the inventor, patentee, assignee or licensee shall be the sole responsibility of the user. For additional information refer to Subsection 7-3 of the FDOT Standard Specifications for Road and Bridge Construction.*

### *Distribution of Exempt Public Documents:*

*It is the policy of the Department to protect the State Highway System's infrastructure from disclosure under Florida's public records law for documents concerning Department structures. This exemption is created by Section 119.07(3)(ee), F.S. and covered by Department Procedure "Distribution of Exempt Public Documents Concerning Department Structures and Security System Plans (Topic No. 050-020-026)." Structure is defined in Section 334.03(28), F.S., as "a bridge, viaduct, tunnel, causeway, approach, ferry slip, culvert, toll plaza, gate, or other similar facility used in connection with a transportation facility." This includes pipes and pipe systems. Therefore, those portions of Department plans that depict pipes, pipe systems, or the internal layout and structural elements of a structure owned or operated by the Department, are exempt from a public records request under Section 119.07(3)(ee), F.S.. This applies to all formats (paper, electronic, etc.), and at any phase of completion (existing, draft, preliminary, phase reviews, final). Entities or persons outside the Department requesting or receiving copies of any portion of plans considered Exempt Documents will need to complete a request form (Form No. 050-020-26). The form also advises the requestor that the entity or person receiving the information shall maintain the confidential and exempt status of the information. This procedure applies to both Department internal or contracted staff who produce such Exempt Documents in their Department work or have other methods of access to such Exempt Documents in the distribution to persons or entities outside of the Department. Refer to Topic No. 050-020-026 for further requirements.*

*The pdf version of these standards can be accessed on the following website:*

*<http://www.dot.state.fl.us/rddesign/DesignStandards/Standards.shtm>*

*Copies of this document can be procured by contacting the following:*

**FLORIDA DEPARTMENT OF TRANSPORTATION**

**MAPS & PUBLICATION SALES**

**MAIL STATION 12**

**605 SUWANNEE STREET**

**TALLAHASSEE, FLORIDA 32399-0450**

**Phone (850) 414-4050**

**Fax Number (850) 414-8036**

*<http://www.dot.state.fl.us/mapsandpublications/>*

**CERTIFICATION STATEMENT**

*I hereby certify that this Design Standard Book was compiled under my responsible charge from designs prepared, examined, adopted and implemented by the Florida Department of Transportation in accordance with established procedures, and as approved by the Federal Highway Administration.*

*As To Structures  
Design Standards Nos.*

199  
289-292  
302 (Sheets 2-4)  
306  
403  
411  
414  
420-425  
470-490  
501,505  
521  
530  
810-880  
5100-5301  
11200-11860  
13417  
17502 (Sheets 3-7)  
17515  
17723,17725  
17743,17745  
17749  
20110-21930

*State Structures Design Engineer  
Robert V. Robertson, Jr.  
P.E. No. 36160*

*Sig:*  
\_\_\_\_\_

*Date:*

*As To Roadway  
Design Standards Nos.*

001-106  
200-288  
293,295  
300-301  
302 (Sheet 1)  
303-305  
307-310  
400-402  
410  
412  
415,417  
430  
461  
500  
506-520  
525-527  
532-540  
546,560  
600-670  
700  
800-803  
17302-17501  
17502 (Sheets 1,2)  
17504, 17505  
17600,17721  
177727-17736  
17748  
17764-17890

*State Roadway Design Engineer  
David C. D'Hagan  
P.E. No. 33713*

*Sig:*  
\_\_\_\_\_

*Date:*

*As To Planning  
Design Standard No.  
17900*

*Manager, Traffic Data Section  
Transportation Statistics Office  
Richard L. Reel, Jr.  
P.E. No. 22400*

*Sig:*  
\_\_\_\_\_

*Date:*

*As To ITS  
Design Standard Nos.  
18100-18305*

*Deputy State Traffic  
Operations Engineer  
Mark C. Wilson  
P.E. No. 46780*

*Sig:*  
\_\_\_\_\_

*Date:*

*As To Landscape  
Architecture  
Design Standard No.  
544*

*State Transportation  
Landscape Architect  
Jeff H. Caster  
LA0001592*

*Sig:*  
\_\_\_\_\_

*Date:*

THIS SHEET INTENDED TO BE BLANK

## TABLE OF CONTENTS

### REVISIONS

Revisions Sheets Since Publication Of The 2008 Booklet (5 Sheets)

### ABBREVIATIONS AND SYMBOLS

001 Standard Abbreviations (3 Sheets)  
002 Standard Symbols (3 Sheets)

### EROSION CONTROL AND WATER QUALITY

100 Temporary Slope Drain And Sod Flume  
101 Trash Retainer And Sediment Basin  
102 Temporary Erosion And Sediment Control (3 Sheets)  
103 Turbidity Barriers  
104 Permanent Erosion Control (2 Sheets)  
105 Shoulder Sodding And Turf On Existing Facilities  
106 Soil Tracking Prevention Device Type A

### DRAINAGE

199 Geotextile Criteria  
200 Structure Bottoms—Type J And P (5 Sheets)  
201 Supplementary Details For Manholes And Inlets (5 Sheets)  
205 Cover Height (6 Sheets)  
206 Trench Drain (2 Sheets)  
210 Curb Inlet Tops—Types 1, 2, 3 And 4  
211 Curb Inlet Tops—Types 5 and 6 (5 Sheets)  
212 Curb Inlet—Type 7  
213 Curb Inlet—Type 8  
214 Curb Inlet Top—Type 9  
215 Curb Inlet Top—Type 10  
216 Closed Flume Inlet (3 Sheets)  
217 Median Barrier Inlets Types 1, 2, 3, 4 And 5 (2 Sheets)  
218 Barrier Wall Inlet (2 Sheets)  
219 Barrier Wall Inlet—Barrier Wall, Concrete (Rigid) (C & G) (2 Sheets)  
220 Gutter Inlet—Type S (3 Sheets)  
221 Gutter Inlet—Type V (2 Sheets)  
230 Ditch Bottom Inlet—Type A (2 Sheets)  
231 Ditch Bottom Inlet—Type B (3 Sheets)  
232 Ditch Bottom Inlets—Types C, D, E And H (7 Sheets)  
233 Ditch Bottom Inlets—Types F And G (2 Sheets)  
234 Ditch Bottom Inlet—Type J (2 Sheets)  
235 Ditch Bottom Inlet—Type K (2 Sheets)  
240 Skimmer For Outlet Control Structures (2 Sheets)  
241 Skimmers For French—Drain Outlets  
245 Underdrain Inspection Box  
250 Straight Concrete Endwalls—Single And Multiple Pipe (2 Sheets)  
251 Straight Concrete Endwalls—Single And Double 60" Pipe (2 Sheets)  
252 Straight Concrete Endwalls—Single And Double 66" Pipe (2 Sheets)  
253 Straight Concrete Endwalls—Single And Double 72" Pipe (2 Sheets)  
255 Straight Concrete Endwall—Single 84" Pipe  
258 Straight Sand—Cement Endwalls  
260 U—Type Concrete Endwalls With Grates—15" To 30" Pipe  
261 U—Type Concrete Endwalls—Baffles And Grate Optional—15" To 30" Pipe (3 Sheets)

### DRAINAGE (CONT.)

264 U—Type Concrete Endwall—Energy Dissipator—30" To 72" Pipe (2 Sheets)  
266 Winged Concrete Endwalls—Single Round Pipe  
268 U—Type Sand—Cement Endwalls  
270 Flared End Section  
272 Cross Drain Mitered End Section (6 Sheets)  
273 Side Drain Mitered End Section (7 Sheets)  
280 Miscellaneous Drainage Details (3 Sheets)  
281 Ditch Pavement And Sodding (2 Sheets)  
282 Back Of Sidewalk Drainage (3 Sheets)  
283 Median Opening Flume  
284 Concrete Shoulder Gutter Spillway  
285 French Drain (2 Sheets)  
286 Underdrain (2 Sheets)  
287 Concrete Pavement Subdrainage (4 Sheets)  
288 Deep Well Injection Box  
289 Concrete Box Culvert Details (LRFD) (7 Sheets)  
291 Supplemental Details For Precast Concrete Box Culverts (5 Sheets)  
292 Standard Precast Concrete Box Culverts (14 Sheets)  
293 Safety Modifications For Inlets In Box Culverts  
295 Safety Modifications For Endwalls

### CURBS AND PAVEMENT JOINTS

300 Curb & Curb And Gutter (2 Sheets)  
301 Turn Lanes  
302 Traffic Separators (4 Sheets)  
303 Curb Return Profiles  
304 Public Sidewalk Curb Ramps (6 Sheets)  
305 Concrete Pavement Joints (4 Sheets)  
306 Bridge Approach Expansion Joint—Concrete Pavement  
307 Miscellaneous Utility Details (3 Sheets)  
308 Concrete Slab Replacement (2 Sheets)  
310 Concrete Sidewalk (2 Sheets)

### TRAFFIC RAILINGS

400 Guardrail (26 Sheets)  
402 Guardrail Transitions And Connections For Existing Bridges (24 Sheets)  
403 Guardrail Transitions For Existing Bridge Traffic Railing Retrofits (3 Sheets)  
410 Concrete Barrier Wall (25 Sheets)  
411 Pier Protection Barrier (10 Sheets)  
412 Low Profile Barrier (5 Sheets)  
414 Type K Temporary Concrete Barrier (15 Sheets)  
415 Temporary Concrete Barrier (10 Sheets)  
417 Inertial Crash Cushion  
420 Traffic Railing — (32" F Shape) (3 Sheets)  
421 Traffic Railing — (Median 32" F Shape) (3 Sheets)  
422 Traffic Railing — (42" Vertical Shape) (3 Sheets)  
423 Traffic Railing — (32" Vertical Shape) (3 Sheets)  
424 Traffic Railing — (Corral Shape) (7 Sheets)  
425 Traffic Railing — (42" F Shape) (3 Sheets)  
430 Optional Crash Cushion Details (2 Sheets)  
461 Opaque Visual Barrier

### TRAFFIC RAILINGS (CONT.)

470 Traffic Railing — (Thrie Beam Retrofit) General Notes & Details (3 Sheets)  
471 Traffic Railing — (Thrie Beam Retrofit) Narrow Curb (4 Sheets)  
472 Traffic Railing — (Thrie Beam Retrofit) Wide Strong Curb Type 1 (4 Sheets)  
473  
474 Traffic Railing — (Thrie Beam Retrofit) Intermediate Curb (4 Sheets)  
475 Traffic Railing — (Thrie Beam Retrofit) Wide Curb Type 1 (4 Sheets)  
476 Traffic Railing — (Thrie Beam Retrofit) Wide Curb Type 2 (4 Sheets)  
480 Traffic Railing — (Vertical Face Retrofit) General Notes & Details (2 Sheets)  
481 Traffic Railing — (Vertical Face Retrofit) Narrow Curb (3 Sheets)  
482 Traffic Railing — (Vertical Face Retrofit) Wide Curb (4 Sheets)  
483 Traffic Railing — (Vertical Face Retrofit) Intermediate Curb (3 Sheets)  
490

### GENERAL

500 Removal Of Organic And Plastic Material (2 Sheets)  
501 Geosynthetic Reinforced Soils (9 Sheets)  
505 Embankment Utilization (4 Sheets)  
506 Miscellaneous Earthwork Details  
510 Super-elevation—Rural Highways, Urban Freeways And High Speed Urban Highways (2 Sheets)  
511 Super-elevation—Urban Highways And Streets (3 Sheets)  
514 Optional Base Group And Structural Numbers (2 Sheets)  
515 Turnouts (7 Sheets)  
516 Turnouts—Resurfacing Projects  
518 Rumble Strips (3 Sheets)  
520 Gravity Wall  
521 Concrete Steps  
525 Ramp Terminals (5 Sheets)  
526 Roadway Transitions (8 Sheets)  
527 Directional Median Opening (3 Sheets)  
530 Rest Area Equipment (3 Sheets)  
532 Mailboxes (3 Sheets)  
535 Tractor Crossings  
540 Settlement Plate  
544 Landscape Installation (3 Sheets)  
546 Sight Distance At Intersections (6 Sheets)  
560 Railroad Crossings

### TRAFFIC CONTROL THROUGH WORK ZONES

600 General Information For Traffic Control Through Work Zones (13 Sheets)  
601 Two-Lane Two-Way, Work Outside Shoulder  
602 Two-Lane Two-Way, Work On Shoulder  
603 Two-Lane Two-Way, Work Within The Travel Way (2 Sheets)  
604 Two-Lane Two-Way, Work In Intersection  
605 Two-Lane Two-Way, Work Near Intersection  
606 Two-Lane Two-Way, Work Within The Travel Way—Signal Control (4 Sheets)  
607 Two-Lane Two-Way, Mobile Operation, Work On Shoulder And Work Within The Travel Way  
608 Two-Lane Two-Way, Temporary Diversion Connection  
611 Multilane, Work Outside Shoulder  
612 Multilane, Work On Shoulder  
613 Multilane, Work Within The Travel Way—Median Or Outside Lane (2 Sheets)  
614 Multilane, Work Within The Travel Way—Center Lane (2 Sheets)  
615 Multilane, Work In Intersection

## TABLE OF CONTENTS

### TRAFFIC CONTROL THROUGH WORK ZONES (CONT.)

616	Multilane, Work Near Intersection-Median Or Outside Lane (3 Sheets)
617	Multilane, Work In Intersection-Center Lane
618	Multilane, Work In Intersection-Two Lanes Closed-45 MPH Or Less
619	Multilane, Mobile Operations Work On Shoulder, Work Within Travel Way
620	Multilane Divided, Temporary Diversion Connection (2 Sheets)
621	Multilane Undivided, Temporary Diversion Connection
622	Multilane, Work Near Intersection-Temporary Diversion Connection -35 MPH or Less
625	Temporary Road Closure-5 Minutes Or Less
628	Two Way Left Turn Lane Closure
630	Crossover For Paving Train Operations, Rural (2 Sheets)
631	Temporary Crossover (2 Sheets)
635	Work In Vicinity Of Railroad Crossing
640	Converting Two-Lanes To Four-Lanes Divided, Rural (2 Sheets)
641	Converting Two-Lanes To Four-Lanes Divided, Urban (3 Sheets)
642	Transitions For Temporary Concrete Barrier Wall On Freeway Facilities
650	Two-Lane Two-Way, Rural Structure Replacement (2 Sheets)
651	Multilane Divided, Maintenance And Construction (2 Sheets)
655	Traffic Pacing (3 Sheets)
660	Pedestrian Control For Closure Of Sidewalks
665	Limited Access, Temporary Opening
667	Toll Plaza, Traffic Control Standards (6 Sheets)
670	Motorist Awareness System

### ROADSIDE OFFSETS

700	Roadside Offsets (2 Sheets)
-----	-----------------------------

### FENCING AND PEDESTRIAN RAILINGS

800	Fence Location (2 Sheets)
801	Fence-Type A (3 Sheets)
802	Fence-Type B (3 Sheets)
803	Cantilever Slide Gate-Type B Fence
810	Bridge Fencing (Vertical) (4 Sheets)
811	Bridge Fencing (Curved Top) (3 Sheets)
812	Bridge Fencing (Enclosed) (4 Sheets)
820	Pedestrian/Bicycle Railing
821	Aluminum Pedestrian/Bicycle Bullet Railing For Traffic Railing (32" F Shape)
822	Aluminum Pedestrian/Bicycle Bullet Railing Details (2 Sheets)
850	Steel Pedestrian/Bicycle Picket Railing (5 Sheets)
851	Bridge Pedestrian/Bicycle Picket Railing (Steel) (2 Sheets)
860	Aluminum Pedestrian/Bicycle Picket Railing (5 Sheets)
861	Bridge Pedestrian/Bicycle Picket Railing (Aluminum) (2 Sheets)
870	Aluminum Pipe Guiderail (5 Sheets)
880	Steel Pipe Guiderail (5 Sheets)

### WALL AND SOUND BARRIER SYSTEMS

5100	Retaining Wall-Cast In Place (2 Sheets)
5200	Precast Sound Barriers-General Notes
5201	Precast Sound Barriers-Texture Options
5202	Precast Sound Barriers-Flush Panel Option (4 Sheets)
5203	Precast Sound Barriers-Recessed Panel Option (5 Sheets)
5204	Precast Sound Barriers-Fire Hose Access Hole & Drainage Details
5205	Precast Sound Barriers-Pile and Post Reinforcing Steel (7 Sheets)
5206	Precast Sound Barriers-Pile Depth and Reinforcing Summary
5207	Precast Sound Barriers-Precast Post Capital
5210	Traffic Railing/Sound Barrier (8'-0") (5 Sheets)
5211	Traffic Railing/Sound Barrier (14'-0") (3 Sheets)
5212	Traffic Railing/Sound Barrier (8'-0") Junction Slab (2 Sheets)
5213	Traffic Railing/Sound Barrier T-Shape Spread Footing (2 Sheets)
5214	Traffic Railing/Sound Barrier L-Shaped Spread Footing (4 Sheets)
5215	Traffic Railing/Sound Barrier Trench Footing
5300	Permanent Retaining Wall Systems (19 Sheets)
5301	Temporary Retaining Wall Systems

### SIGNING AND MARKINGS

11200	Multi-Column Ground Sign (2 Sheets)
11300	Steel Overhead Sign Structures
11310	Cantilever Sign Structure (5 Sheets)
11320	Span Sign Structure (5 Sheets)
11860	Single Column Ground Signs (8 Sheets)
13417	Mounting Exit Numbering Panels To Highway Signs
17302	Typical Sections For Placement Of Single & Multi-Column Signs
17328	Typical Signing For Truck Weigh & Inspection Stations (2 Sheets)
17344	School Signs & Markings (6 Sheets)
17345	Interchange Markings (4 Sheets)
17346	Special Marking Areas (14 Sheets)
17347	Bicycle Markings (4 Sheets)
17349	Traffic Controls For Street Terminations
17350	Signing For Motorist Services
17351	Welcome Center Signing (2 Sheets)
17352	Typical Placement Of Reflective Pavement Markers (2 Sheets)
17355	Special Sign Details (11 Sheets)
17356	Span Wire Mounted Sign Details
17357	Bridge Weight Restrictions
17359	Rural Narrow Bridge Treatment (2 Sheets)

### ROADWAY LIGHTING

17500	Conventional Lighting (3 Sheets)
17501	Highway Lighting General Notes
17502	Highmast Lighting (7 Sheets)
17504	Service Point Details
17505	External Lighting For Signs (2 Sheets)
17515	Standard Roadway Aluminum Lighting (8 Sheets)

### TRAFFIC SIGNAL AND EQUIPMENT

17600	Motorist Aid Call Box (3 Sheets)
17721	Conduit Installation Details (2 Sheets)
17723	Steel Strain Pole (3 Sheets)
17725	Concrete Poles (2 Sheets)
17727	Signal Cable And Span Wire Installation Details (2 Sheets)
17733	Aerial Interconnect
17736	Electric Power Service
17743	Standard Mast Arm Assemblies (3 Sheets)
17745	Mast Arm Assemblies (5 Sheets)
17748	Free-Swinging, Internally-Illuminated Street Sign Assemblies
17749	Damping Device For Miscellaneous Structures
17764	Pedestrian Control Signal Installation Details
17781	Vehicle Loop Installation Details (2 Sheets)
17784	Pedestrian Detector Assembly Installation Details (2 Sheets)
17841	Cabinet Installation Details
17870	Standard Signal Operating Plans (2 Sheets)
17881	Advance Warning For R/R Crossing
17882	Railroad Grade Crossing Traffic Control Devices (4 Sheets)
17890	Traffic Control Devices For Movable Span Bridge Signals (3 Sheets)

### MISCELLANEOUS

17900	Traffic Monitoring Site (7 Sheets)
-------	------------------------------------

### ITS

18100	CCTV Pole Placement
18101	Typical CCTV Site
18102	CCTV Pole Grounding (2 Sheets)
18104	CCTV Cabinet Equipment Layout
18105	CCTV Block Diagram
18107	Ground Mounted CCTV Cabinet
18108	Pole Mounted CCTV Cabinet
18110	Camera Mounting Details (2 Sheets)
18111	Steel CCTV Pole (2 Sheets)
18113	Concrete CCTV Pole (2 Sheets)
18202	Fiber Optic Pullbox And Trench Details
18204	Fiber Optic Splice Box And Pullbox
18300	DMS Cabinet And Sign Wiring And Block Diagram
18301	DMS Cabinet Layout
18302	Typical DMS Mounting Details
18303	DMS Structures Details (2 Sheets)
18305	DMS Grounding Details (2 Sheets)

## TABLE OF CONTENTS

### PRESTRESSED CONCRETE AASHTO BEAMS

- 20110 Typical AASHTO And Bulb-T Beam Details and Notes
- 20120 AASHTO Type II-Beam Standard Details
- 20130 AASHTO Type III Beam - Standard Details
- 20140 AASHTO Type IV Beam - Standard Details
- 20150 AASHTO Type V Beam - Standard Details
- 20160 AASHTO Type VI Beam - Standard Details
- 20172 Florida Bulb-T 72 Beam - Standard Details
- 20178 Florida Bulb-T 78 Beam - Standard Details
- 20199 Build-Up And Deflection Data For AASHTO And Bulb-T Beams

### PRESTRESSED CONCRETE FLORIDA U BEAMS (FUB)

- 20210 Typical Florida U Beam Details And Notes (2 Sheets)
- 20248 Florida U 48 Beam - Standard Details (3 Sheets)
- 20254 Florida U 54 Beam - Standard Details (3 Sheets)
- 20263 Florida U 63 Beam - Standard Details (3 Sheets)
- 20272 Florida U 72 Beam - Standard Details (3 Sheets)
- 20299 Build-Up And Deflection Data For Florida U Beams

### PRESTRESSED CONCRETE INVERTED-T BEAMS

- 20310 Typical Inverted-T Beam Details And Notes
- 20320 Inverted-T Beam Standard Details

### CONCRETE SHEET PILES

- 20400 Notes And Details For Precast Concrete Sheet Piles
- 20410 Precast Concrete Sheet Pile Type "A" - 10 Inch Thick
- 20412 Precast Concrete Sheet Pile Type "A" - 12 Inch Thick
- 20430 Precast Concrete Sheet Pile Type "B" - Variable Angle Corner Pile
- 20440 Precast Concrete Sheet Pile Type "C" - Right Angle Corner Pile

### BEARING PADS

- 20500 Composite Elastomeric Bearing Pads
- 20501 Beveled Bearing Plate Details-Prestressed AASHTO And Bulb-T Beams
- 20502 Beveled Bearing Plate Details-Florida U-Beams

### SQUARE AND ROUND CONCRETE PILES

- 20600 Notes And Details For Square Prestressed Concrete Piles
- 20601 Square Prestressed Concrete Pile Splices
- 20602 EDC Instrumentation For Square Prestressed Concrete Piles
- 20612 12" Square Prestressed Concrete Pile
- 20614 14" Square Prestressed Concrete Pile
- 20618 18" Square Prestressed Concrete Pile
- 20620 20" Square Prestressed Concrete Pile
- 20624 24" Square Prestressed Concrete Pile
- 20630 30" Square Prestressed Concrete Pile
- 20631 High Moment Capacity 30" Square Prestressed Concrete Pile
- 20654 54" Precast/Post-Tensioned Concrete Cylinder Pile (2 Sheets)
- 20660 60" Prestressed Concrete Cylinder Pile (2 Sheets)

### APPROACH SLABS

- 20900 Approach Slabs (Flexible Pavement Approaches) (2 Sheets)
- 20910 Approach Slabs (Rigid Pavement Approaches) (2 Sheets)

### BRIDGE EXPANSION JOINTS

- 21100 Strip Seal Expansion Joint (3 Sheets)
- 21110 Poured joint With Backer Rod Expansion Joint System (2 Sheets)

### STRUCTURES LIGHTING AND UTILITIES

- 21200 Light Pole Pilaster (2 Sheets)
- 21210 Utility Conduit Details (2 Sheets)
- 21220 Navigation Light System Details (Fixed Bridges) (2 Sheets)
- 21240 Maintenance Lighting For Box Girders (2 Sheets)

### STANDARD BAR BENDING DETAILS

- 21300 Standard Bar Bending Details

### TEMPORARY DETOUR BRIDGES

- 21600 Temporary Detour Bridge General Notes And Details (7 Sheets)
- 21610 Temporary Detour Bridge Details-Timber Pile Foundations (3 Sheets)
- 21620 Temporary Detour Bridge Details-Steel H Pile Foundations (2 Sheets)
- 21630 Temporary Detour Bridge Details-Steel Pipe Pile Foundations (3 Sheets)

### POST-TENSIONING DETAILS

- 21801 Post-Tensioning Vertical Profiles (2 Sheets)
- 21802 Post-Tensioning Anchorage Protection
- 21803 Post-Tensioning Anchorage And Grouting Details (3 Sheets)

### FENDER SYSTEMS DETAILS

- 21900 Fender System General Notes And Layout (2 Sheets)
- 21910 Fender System Heavy Duty (5 Sheets)
- 21920 Fender System Medium Duty (5 Sheets)
- 21930 Fender System Light Duty (5 Sheets)

**Revisions  
Design Standards 2010**

Index Number	Sheet Number	Description	Index Number	Sheet Number	Description
001	1 thru 3	Added the following standard abbreviations: B Base Line, Base Line Control FL Flow Line GRI Geosynthetic Research Institute HDPE High Density Polyethylene NPS Nominal Pipe Size  Deleted the following standard abbreviations: Bbl Barrel FRCP Fiber Reinforced Concrete Pipe FRP Fiber Reinforced Pipe FS Far Side	233	1 thru 2	Index was expanded due to font size change.
			234	1 thru 2	Index was expanded due to font size change.
				2 of 2	Under Pavement & Sodding detail changed "1/2" Exp. Joint" to "1/2" Preformed Joint Filler".
			235	1 of 2	"GENERAL NOTES", Note 3, deleted "Alternate B" replaced with "Index 200"; Note 8 changed "Specification Section 962" to "Specification Section 975".
			245	1 of 1	"GENERAL NOTES" Note 2, delete and replace with the following: "Concrete shall be Class I (Structural), except ASTM C478 (4000 psi) concrete may be substituted for precast items manufactured in plants meeting the requirements of Section 449 of the Specifications. Box shall be reinforced with No. 3 bars (Grade 60) on 8" centers both ways, sides and bottom.
002	2 of 3	Deleted Hand Drafting Symbols	250	1 of 2	"GENERAL NOTES" Note 5, deleted and replaced with the following: "Concrete shall be Class I (Structural), except ASTM C478 (4000 psi) concrete may be substituted for precast items manufactured in plants meeting the requirements of Section 449 of the Specifications."
102	2 of 3	NOTES FOR SYNTHETIC BALES OR BALE TYPE BARRIERS, Note 2, deleted the text "trenched 3" to 4" and" from the first sentence.	251	1 of 2	"GENERAL NOTES" Note 4, deleted and replaced with the following: "Concrete shall be Class II, except ASTM C478 (4000 psi) concrete may be substituted for precast items manufactured in plants meeting the requirements of Section 449 of the Specifications."
104	2 of 2	RURAL DIVIDED detail, changed "5' Shoulder Pavement" to "4' Shoulder Pavement".	252	1 of 2	"GENERAL NOTES" Note 4, deleted and replaced with the following: "Concrete shall be Class II, except ASTM C478 (4000 psi) concrete may be substituted for precast items manufactured in plants meeting the requirements of Section 449 of the Specifications."
105	1 of 1	TREATMENT I, Criteria for using Treatment I, replaced text of the last bullet with the following: "resurfacing build-up is less than 3" "	253	1 of 2	"GENERAL NOTES" Note 4, deleted and replaced with the following: "Concrete shall be Class II, except ASTM C478 (4000 psi) concrete may be substituted for precast items manufactured in plants meeting the requirements of Section 449 of the Specifications."
200	1 of 5	TOP SLAB REINFORCING STEEL DIAGRAM (ALTERNATE B) to the notes "2 Additional Bars A @ 5" O.C." and "2 Additional Bars B @ 5" Max. O.C. Each Side Of Opening", added "(Minimum #4 Bars)".	255	1 of 2	"GENERAL NOTES" Note 4, deleted and replaced with the following: "Concrete shall be Class II, except ASTM C478 (4000 psi) concrete may be substituted for precast items manufactured in plants meeting the requirements of Section 449 of the Specifications."
	2 of 5	Note 9, Delete second sentence and substitute, "Additional bars used to restrain hole formers for precast structures with grouted pipe connections, may be left flush with the hole surface."	260	1 of 1	"GENERAL NOTES" Note 3 changed "Specification Section 962" to "Specification Section 975".
	4 of 5	SLAB AND WALL DESIGN TABLE NOTES, added the following to the end of Note 10: "See Index No. 201, Sheet 4 for allowable bar spacing adjustments when larger areas of reinforcing are substituted."	261	1 of 3	"GENERAL NOTES" Note 4 changed "Specification Section 962" to "Specification Section 975".
201	4 of 5	"Revised title of notes to ""NOTES FOR PRECAST OPTIONS AND EQUIVALENT REINFORCEMENT SUBSTITUTION"" and added the following to Note 4, ""When an increased area of reinforcing is provided, then the maximum bar spacing may be increased by the squared ratio of increased steel area, but not to exceed 12 inches: Max. Bar Spacing Provided < Max. Bar Spacing Required x (Steel Area Provided/Min. Steel Area Required) <sup>2</sup> "	264	1 thru 2	Index was expanded due to font size change. General note 3 changed.
205	1 of 6	Changed maximum size of allowed PVC pipe to 36".	270	1 of 1	"GENERAL NOTES" Note 2 changed "Specification Section 941-1.5" to "Specification Section 449". Changed Note 3.
	2 of 6	ROUND PIPE DIMENSIONS, deleted the column, "Wall Thickness (In.) Class III" and subcolumn "NRCHP" and heading "SRCP". Also deleted the ** note at the bottom of the table.	272	6 of 6	Reordered "GENERAL NOTES" and changed "Class I concrete" to "Class NS concrete".
	3 of 6	NOTES: deleted note 4; table "PIPE ARCH: SPIRAL RIB: 3/4" x 3/4" x 7 1/2" RIB SPACING..." deleted references to note 4; table "ROUND PIPE - SPIRAL RIB", "Maximum Height of Fill (Ft.)", "Sheet Thickness In Inches (Gage)", "0.138 (10)" added measurements.	273	1 thru 7	Index was expanded due to font size change.
210	1 of 1	Delete General Note 4, and substitute the following: "For precast units the rear wall and apron may be precast as a separate piece from the top slab. Provide a minimum of 7 ~ #4 dowels in accordance with Index No. 201 "OPTIONAL CONSTRUCTION JOINTS".		7 of 7	"GENERAL NOTES", Note 8, deleted "Class I concrete" and substituted "Class NS concrete".
211	1 thru 5	Revised index completely 3 sheets added, Reinforcing configuration and C.I.P. details revised; precast and WWR details added. Changed Note 4 to allow 4'-0" round risers.	280	1 thru 3	Index was expanded due to font size change.
213	1 of 1	In PLAN view changed "1/2" Exp. Joint (Typ)" to "1/2" Preformed Joint Filler (Typ)".		1 of 3	"DISSIMILAR TYPES CONCRETE JACKET FOR CONNECTING DISSIMILAR TYPES OF PIPE AND CONCRETE PIPES WITH DISSIMILAR JOINTS" detail, added the note, "Alternate connection must be approved by the State Drainage Engineer."
218	2 of 2	"STEEL GRATE", "TOP VIEW", for the overall dimension on the left side of the grate, inserted "44 1/4" ". For the small dimension at the upper left corner of the grate, inserted "3 1/2" "	282	1 thru 3	Index was expanded due to font size change.
219	1 of 2	In PLAN view and Section HH changed "Expansion Joint (Typ)" and "Expansion Material Joint" to "1/2" Preformed Joint Filler (Typ)".		1 of 3	"FRONT ELEVATION" and "SECTION AA" details changed "1/2" Exp. Matl. " to "1/2" Preformed Joint Filler".
220	1 of 3	"GUTTER INLET TYPE S", "SECTION BB", Changed the vertical dimension between the top of the inlet and the grate elevation from "5 1/2" to "4 1/2" ".  "SECTION AA", at the top right corner, for precast thickness changed " 6" " to " 3" " (same as left side).  "SECTION BB", at the top, changed "3'-11" Precast" to " 4'-3" Precast". "PLAN", at the top, changed " 3'-11" Precast to " 4'-3" Precast".	284	2 of 3	"PLAN" and "SECTION AA" details changed "1/2" Exp. Matl. " to "1/2" Preformed Joint Filler".
			287	1 of 1	Deleted note "1" and substituted the following: "1. Spillway to be paid for as Shoulder Gutter, LF." Deleted note "2", and substituted the following: "2. If spillway empties into an unpaved ditch the detail should be modified as necessary."
			287	1 thru 4	Sheet 3 is new. Renumbered other sheets.
				1 of 4	Changed all 3 occurrences of "Class I concrete" to "Class NS concrete".
			288	1 of 1	New Index added "DEEP WELL INJECTION BDX".
230	1 of 2	In "PLAN" view changed "1/2" Exp. Joint (typ)" to "1/2" Preformed Joint Filler (Typ)". Section E-E, Changed 4Z15.9 shape to built up section (3.5 x 3 x 1/2 L + 1/2 x 3 Bar) for grating.	289	6 of 7	Changed "FLARED ENDWALL" to "FLARED WINGWALL" and "STRAIGHT ENDWALL" to "STRAIGHT WINGWALL".
231	1 of 3	"DITCH BOTTOM INLET TYPE B", "SECTION BB", upper left side, deleted the dimension "2'-6" (Min.)" and replaced with "1'-10" (Min.)".	291	1 of 5	Changed "Class I Concrete" to "Class NS".
232	1 thru 7	Index was expanded due to font size change.		5 of 5	Changed "Bond Beam" to "Link Slab", and "Class I Concrete" to "Class NS".
			292	2 of 14	"GENERAL NOTES" note 1, changed AASHTO LRFD Bridge Specifications, to "4th Edition"; added note 10.



**Revisions  
Design Standards 2010**

Index Number	Sheet Number	Description	Index Number	Sheet Number	Description
295	1 of 1	"GENERAL NOTES" Note 2 changed "Specification Section 962" to "Specification Section 975".	421	1 of 3	Changed REFLECTIVE RAILING MARKERS note, "Reflective Railing Markers shall meet Specification Section 993. Install markers on top of the Traffic Railing along the centerline at the spacing shown in the table above. Reflector color (white or yellow) shall match the color of the near edgeline. The cost of the reflective markers shall be included in the Contract Unit Price for the Traffic Railing."
300	1 thru 2	Index was expanded due to change in font.			
304	6 of 6	Added alternate location of detectable warnings on linear ramps. Added note "On curb ramps, landings and flush transitions perpendicular to the curb line: Rows of domes shall be aligned with the centerline of the ramp. (See Pictorial View A)" at top of sheet. Added Rail Road Crossing PLAN view.	422	1 of 3	Added the following to the NAME, DATE AND BRIDGE NUMBER note: "The Name shall be as shown in the General Notes in the Structures Plans."; Changed REFLECTIVE RAILING MARKERS note.
305	1 & 4 of 4	Deleted bar spacing table and revised notes (Sheet 1); Changed width of outside lanes (Sheet 4).			Changed REFLECTIVE RAILING MARKERS note, "Reflective Railing Markers shall meet Specification Section 993. Install markers on top of the Traffic Railing 2" from the face on the traffic side at the spacing shown in the table above. Reflector color (white or yellow) shall match the color of the near edgeline. The cost of the reflective markers shall be included in the Contract Unit Price for the Traffic Railing."
307	2 of 3	"UTILITY CONFLICT PIPES THRU STORM SEWER STRUCTURES" changed to "UTILITY CONFLICT PIPES THRU STORM DRAIN STRUCTURES"			
310	1 of 2	"SIDEWALK WITH EDGE BEAM FOR SURFACE MOUNTED RAILINGS", "Clear Width", deleted "3' Min." and substituted "4' Min. *".	423	1 of 3	Added the following to the NAME, DATE AND BRIDGE NUMBER note: "The Name shall be as shown in the General Notes in the Structures Plans."; Bicycle Railing to "Special Height Bicycle Railing" and Post "B" to Post "B1".
		"NOTES FOR CONCRETE SIDEWALK ON CURBED ROADWAYS", deleted "Note 1", and substituted the following: "1. Sidewalks shall be constructed in accordance with Section 522 of the FDOT Standard Specifications. Public sidewalk curb ramps shall include detectable warnings and be constructed in accordance with Index No. 304. Detectable warnings are not required where sidewalks intersect urban flared turnouts."			"TRAFFIC RAILING-(32" VERTICAL SHAPE)", deleted the "REFLECTIVE RAILING MARKERS" note and substituted the following: "Reflective Railing Markers shall meet Specification Section 993. Install markers on top of the Traffic Railing 2" from the face on the traffic side at the spacing shown in the table above. Reflector color (white or yellow) shall match the color of the near edgeline. The cost of the reflective markers shall be included in the Contract Unit Price for the Traffic Railing."
		"Note 3" , deleted.		2 of 3	Changed Bicycle Railing to "Special Height Bicycle Railing" and Post "B" to Post "B1".
	2 of 2	"NOTES FOR CONCRETE SIDEWALKS ON UNCURBED ROADWAYS", Changed Note 2 to "Provide detectable warnings that extend the fullwidth of the sidewalk and 24" deep from the edge of pavement where sidewalks adjoin the following vehicular ways: side roads and streets driveways with signalized entrances driveways with entrance volumes greater than 600 vpd driveways with entrance speeds of 25 mph or greater right in - right out composite driveways.		3 of 3	Changed 83 degrees to 93 degrees in CONVENTIONAL REINFORCING STEEL BENDING DIAGRAM Cross-slope table.
400	1 thru 26	Index expanded by one sheet due to font size change and added new sheet 2, "APPROACH END ANCHORAGE DETAILS", Index renumbered.	424	1 of 7	Added the following to the NAME, DATE AND BRIDGE NUMBER note: "The Name shall be as shown in the General Notes in the Structures Plans."
	1 of 26	"GENERAL NOTES" Note 17 changed "Specification Section 971" to "Specification Section 975".	425	1 of 3	"TRAFFIC RAILING - (CORRAL SHAPE)", deleted the "REFLECTIVE RAILING MARKERS" note and substituted the following: "Reflective Railing Markers shall meet Specification Section 993. Install markers on top of the Traffic Railing 2" from the face on the traffic side at the spacing shown in the table above. Reflector color (white or yellow) shall match the color of the near edgeline. The cost of the reflective markers shall be included in the Contract Unit Price for the Traffic Railing."
	2 of 26	New sheet added showing limits of pay for guardrail, details of shoulder treatment and miscellaneous asphalt for guardrail approach end treatments.			Added the following to the NAME, DATE AND BRIDGE NUMBER note: "The Name shall be as shown in the General Notes in the Structures Plans."
	3 of 26	Corrected spelling of guardrail in last paragraph.			"TRAFFIC RAILING - (42" F SHAPE)", added the following note: "REFLECTIVE RAILING MARKERS: Reflective Railing Markers shall meet Specification Section 993. Install markers on top of the Traffic Railing 2" from the face on the traffic side at the spacing shown in the table above. Reflector color (white or yellow) shall match the color of the near edgeline. The cost of the reflective markers shall be included in the Contract Unit Price for the Traffic Railing."
	15 of 26	"LOCATIONS ON FRONT SLOPES", deleted the details for guardrail on slope and rubrail termination and the chart for lateral placement on slopes. (See sheet 26)			
	16 of 26	Deleted "REFLECTORS- DETAIL M" (See sheet 17)			
	26 of 26	Added "GUARDRAIL ON SLOPES", details for guardrail on slope and rubrail termination and the chart for lateral placement on slopes.	470	1 of 3	Added Field testing proof loads to the ADHESIVE BONDED ANCHORS AND DWELS note; "TRAFFIC RAILING-(THRIE BEAM RETROFIT) GENERAL NOTES & DETAILS", deleted the "BRIDGE NAME PLATE" note and substituted the following: "If a portion of the existing Traffic Railing is to be removed that carries the bridge name, number and or date, or if the installation of the Traffic Railing (Thrie Beam Retrofit) will obscure the bridge name, number and or date, then replace the information that has been removed or obscured, with 3" tall black lettering on white nonreflective sheeting applied to the top of the adjacent guardrail. The information must be clearly visible from the right side of the approaching travel lane. The sheeting and adhesive backing shall comply with Specification Section 994 and may comprise of individual decals of letters and numbers."
410	1 thru 25	Index completely revised and reorganized.			
411	2 of 10	Changed tangent offsets In Detail 'A' to "2.49'-Design Speed ≤45 mph; 1.76' - Design Speed ≥50 mph".			
	4 of 10	Changed tangent offsets In Detail 'B' to "2.49'-Design Speed ≤45 mph; 1.76' - Design Speed ≥50 mph".			
414	1 of 15	Updated Specification reference Section 971 to 975; Added steel option to ALTERNATE DESIGN note.			
	5 of 15	Added PTFE tape option to anchor bolt details.			
415	4 of 10	"NOTES FOR WALL END SHIELDING", Note 1, changed the second sentence to: "Except where the plans designate a particular type crash cushion for a specific location, the contractor has the option to construct any of the redirective crash cushions listed on the Qualified Products List, subject to the uses and limitations described on their respective drawings."		3 of 3	Added the following note: "NEOPRENE PADS: Neoprene pads must be plain pads with a durometer hardness of 60 or 70 and meet the requirements of Specification Section 932, except that testing of the finished pad will not be required."
		"ANCHOR PLATE BDLTS", upper note, changed "?" to "3/4"."	471	2 of 4	Changed offset of 7/8" dia. anchor bolts to 2 3/4" from back edge of base plate in SECTION B-B.
420	1 of 3	Added the following to the NAME, DATE AND BRIDGE NUMBER note: "The Name shall be as shown in the General Notes in the Structures Plans."; Changed REFLECTIVE RAILING MARKERS note.	472	2 of 4	"SECTION A-A" and "SECTION B-B", changed "Resilient Pad" to "Neoprene Pad".
		Changed REFLECTIVE RAILING MARKERS note, "Reflective Railing Markers shall meet Specification Section 993. Install markers on top of the Traffic Railing 2" from the face on the traffic side at the spacing shown in the table above. Reflector color (white or yellow) shall match the color of the near edgeline. The cost of the reflective markers shall be included in the Contract Unit Price for the Traffic Railing."	473	2 of 4	"SECTION A-A" and "SECTION B-B", changed "Resilient Pad" to "Neoprene Pad".
			474	2 of 4	"SECTION A-A" and "SECTION B-B", changed "Resilient Pad" to "Neoprene Pad".
				4 of 4	"SECTION C-C", changed "Resilient Pad" to "Neoprene Pad".

**Revisions  
Design Standards 2010**

Index Number	Sheet Number	Description	Index Number	Sheet Number	Description
475	2 of 4	"SECTION A-A" and "SECTION B-B", changed "Resilient Pad" to "Neoprene Pad".	600	3 of 13	LANE WIDTHS, in the second sentence, change the word "expected" to "excepted".
476	2 of 4	"SECTION A-A" and "SECTION B-B", changed "Resilient Pad" to "Neoprene Pad".		5 of 13	Changed note under "SIGN COVERING AND INTERMITTENT WORK STOPPAGE SIGNING"; added information for the use of the new "PROJECT INFORMATION SIGN".
480	1 of 2	"TRAFFIC RAILING-(VERTICAL FACE RETROFIT) GENERAL NOTES & DETAILS", added the following to the "ADHESIVE-BONDED ANCHORS AND DOWELS" note, "The field testing proof loads required by Specification Section 416 shall be 23,800 lbs. for Dowel Bars 6D on the inside face (traffic side) of the railing (1'-0" embedment) and 18,500 lbs for Dowel Bars 6D along the outside face of the traffic railing (5" min. embedment)." Added NEOPRENE PADS note.  Also deleted the "REFLECTIVE RAILING MARKERS" note and substituted the following: "Reflective Railing Markers shall meet Specification Section 993. Install markers on top of the Traffic Railing 2" from the face on the traffic side at the spacing shown in the table below. Reflector color (white or yellow) shall match the color of the near edgeline."		6 of 13	GENERAL NOTES, deleted note 1, substituted the following: "1. All signs shall be post mounted when work operations exceed one day except for: a) Road closure signs mounted in accordance with the vendor drawing for the Type III Barricade shown on the QPL. b) Pedestrian advanced warning or regulatory signs mounted on sign supports shown on the QPL."  "2. POST SIGN SUPPORT MOUNTING DETAILS", updated text to include a tolerance between sign supports. Insert "+/- 3" " after "1'-6" " and insert "+/- 6" " after "2'-6" ".
	2 of 2	CONVENTIONAL REINFORCING STEEL BENDING DIAGRAM, added Bars 5E, 5F and 4G for Index No. 484			POST AND FOUNDATION TABLE FOR WORK ZONE SIGNS, expanded Note 2 by adding: "unless otherwise specified in the vendor drawing on the QPL."
484	1-10 of 10	New Index added TRAFFIC RAILING (VERTICAL FACE RETROFIT) SPREAD FOOTING APPROACH			POST MOUNTED SIGN NOTES, added new notes 1 and 12.
500	2 of 2	"HALF SECTION" detail, deleted "Storm Sewer Mains" replaced with "Storm Drain Trunk Lines"		7 of 13	Added new sheet showing Project Information Sign and renumbered index.
501	3-9 of 9	Changed the REQUIRED TEST METHOD for Burst Strength, Soil-Geosynthetic Friction, Creep Reduction Factor & Joint Overlap to ASTM D 6706.	605	1 of 1	"GENERAL NOTES", deleted the text of "Note 8" and substituted the following: "The two channelizing devices directly in front and directly at the end of the work area may be omitted provided vehicles in the work area have high intensity rotating, flashing, oscillating or strobe lights operating."
	4 of 9	Updated values for COMTRAC 70.70; Deleted AMOCD 2006, 2016 & 2044; Added GEOTEX 315ST, 2x2HF, 4x4, 3x3HF, 4x4HF & 4x6 woven geogrids.			Added new heading "DURATION NOTE" and placed the following note under this heading: 1. ROAD WORK AHEAD sign may be omitted if all of the following conditions are met: a) Work operations are 60 minutes or less. b) Speed is 45 mph or less. c) No sight obstructions to vehicles approaching the work area for a distance of 600 feet. d) Vehicles in the work area have high-intensity, rotating, flashing, oscillating, or strobe lights operating. e) Volume and complexity of the roadway has been considered.
	5 of 9	Changed Joint Strength Overlap value to 1.2 for all Marafi products.			
	6 of 9	Deleted Application Usage 3 & 4 for SYNTEN SF 11 & SF 12.			
	7 of 9	Added Fornir 20			
	8 of 9	Changed Creep Resistance and Creep Reduction Factors for TENSAR BX 1120, BX 1200, BX 1220 & BX 1500			
	9 of 9	Updated values for TENAX MS 220 & TENAX MS 330. Added Combigrid 30/30, Secugrid 20/20 & 30/30 extruded geogrids.	625	1 of 1	New Index added "TEMPORARY ROAD CLOSURE- 5 MINUTES OR LESS".
505	1-4 of 4	Sheet 3 is new. Renumbered other sheets.	655	1-3 of 3	New Index added "TRAFFIC PACING-LIMITED ACCESS".
515	5 of 7	In second symbolized note changed "Section 102-6" to "Section 102-8".	667	1-6 of 6	New Index added "TOLL PLAZAS".
	6 of 7	"PAVEMENT STRUCTURE FOR TURNOUTS AND AUXILIARY LANES TABLE 515-1", "NOTES", Note 5, Deleted "Class I concrete" substituted "Class NS concrete".	801	1 of 3	"GENERAL NOTES", Note 15 and 21, deleted "Class I" and substituted "Class NS".
518	3 of 3	Revised width of rigid pavement outside travellane and changed location of rumble strip.	802	1-3 of 3	Added tolerance to ground clearance; revised Notes 7a and 7b; rearranged sheets.
520	1 of 1	"GENERAL NOTES", Note 7, Deleted "Class I Concrete (Retaining Walls)" and substituted "Class NS Concrete"		1 of 3	"GENERAL NOTES", Note 6 and 13, deleted "Class I concrete" and substituted "Class NS concrete" for all occurrences.
546	1 of 6	Added detail "PLAN", "PICTORIAL" and ** note. Index sheets reordered.	803	1 of 1	"GENERAL NOTES", Note 4, deleted both occurrences of "Class I" and substituted "Class NS".
	5 of 6	Under "NOTES FOR 4-LANE DIVIDED ROADWAY", Note 1, changed reference from "Sheet 6" to "Sheet 2".	810	2 of 4	Deleted "Section 971" and substituted "Section 975" in ANCHOR RODS, NUTS AND WASHERS note.
600	2 of 13	OVERHEAD WORK, deleted "OPTION 4 - - -" and substituted the following: OPTION 4 (OVERHEAD WORK MAINTAINING TRAFFIC WITH NO ENCROACHMENT BELOW THE OVERHEAD WORK AREA) Traffic shall be detoured, shifted, diverted or paced as to not encroach in the area directly below the overhead work operations in accordance with the appropriate standard index drawing or detailed in the plans. This option applies to, but not limited to, the following construction activities: (a) Beam, girder and segment placement. (b) Deck form placement and removal. (c) Concrete deck placement. (d) Railing construction located at edge of deck. (e) Structure demolition.  DEFINITIONS, added the following after definition of TRAVEL WAY: a. Travel Lane: The designated widths of roadway pavement marked to carry through traffic and to separate it from opposing traffic or traffic occupying other lanes. b. Auxiliary Lane: The designated widths of roadway pavement marked to separate speed change, turning, passing and climbing maneuvers from through traffic.  CLEAR ZONE WIDTHS FOR WORK ZONES, deleted the text "travel" in the first sentence and substituted "traffic".  Replaced chart "CLEAR ZONE WIDTHS FOR WORK ZONES".	811	3 of 3	Deleted "Section 971" and substituted "Section 975" in ANCHOR RODS, NUTS AND WASHERS note.
			812	2 of 4	Deleted "Section 971" and substituted "Section 975" in ANCHOR RODS, NUTS AND WASHERS note.
			820	1 of 1	Changed Top Rail to "Special Height Bicycle Railing" and added new Post "B2" for 3'-6" height Pedestrian/Bicycle Railing.
			821	1 of 1	Changed designation of 4'-6" tall railing to "Special Height Bicycle Railing" and added 3'-6" tall Pedestrian/Bicycle Railing.
			822	1 of 2	Changed designation of 4'-6" tall railing to "Special Height Bicycle Railing" and "Post B" to "Post B1"; Added "Post B2" details.
			850	1 of 5	Changed "Pedestrian Railing" to "Pedestrian/Bicycle Railing" and "Bicycle Railing" to "Special Height Bicycle Railing"; Added anchor bolt requirements to SHOP DRAWINGS note.
				2 of 5	Added "DETAIL FOR NON-CONTINUOUS RAILING AT CORNERS" detail. Changed Pedestrian and Bicycle Railing designation; maximum ramp length for slopes less than 6.25%; and minimum clear picket opening at post to 3/4".
				3 of 5	Changed Pedestrian and Bicycle Railing designation.
				4 of 5	Added requirement for set screw to be set flush against outside face of rail and 18-8 Alloy option in DETAILS "D" & "E", option to notch post in SECTION G-G, and 1/4" joint tolerance in DETAIL "D".
				5 of 5	Added DETAIL "F" and note (*) to ANCHOR BOLT TABLE. Changed Pedestrian and Bicycle Railing designation. Corrected height dimension on steps to top of nosing.

**Revisions  
Design Standards 2010**

Index Number	Sheet Number	Description	Index Number	Sheet Number	Description
851	1 of 2	Changed Pedestrian and Bicycle Railing designation.	5204	1 of 1	Changed "Ribbed" to "Slotted" in PLUG DETAIL.
	2 of 2	Added requirement for set screw to be set flush against outside face of rail and 18-8 Alloy option in DETAIL "B". Changed field splice joint tolerance to 1/4" in DETAIL "B".	5205	1, 3, 4 & 6 of 7	Added note in Elevation Views to 'Extend post 2" above high side wall panel when post caps are shown in the plans'.
860	1 of 5	Changed "Pedestrian Railing" to "Pedestrian/Bicycle Railing" and "Bicycle Railing" to "Special Height Bicycle Railing"; Added anchor bolt requirements to SHOP DRAWINGS note. Added filler metal ER4043 to WELDING note.		2 of 7	Added tolerance between Top of Precast Collar and Auger Cast Pile; Changed "Composite Bearing Pads" to "Fiber Reinforced Bearing Pads".
	2 of 5	Added "DETAIL FOR NON-CONTINUOUS RAILING AT CORNERS" detail. Changed Pedestrian and Bicycle Railing designation; maximum ramp length for slopes less than 6.25%; and minimum clear picket opening at post to 3/4".		5 of 7	Changed "Composite Bearing Pads" to "Fiber Reinforced Bearing Pads".
	3 of 5	Changed Pedestrian and Bicycle Railing designation.	5206	7 of 7	Added "Octagonal Precast Collar" details and tolerance between Top of Precast Collar and Auger Cast Pile; Changed "Composite Bearing Pads" to "Fiber Reinforced Bearing Pads".
	4 of 5	Added requirement for set screw to be set flush against outside face of rail and 18-8 Alloy option in DETAILS "D" & "E"; option to notch post in SECTION G-G; 1/4" joint tolerance in DETAIL "D"; Type B (Nonwelded) connection detail in SECTION A-A. Changed Expansion Joint sleeve embedded length to 10" in DETAIL "D" and picket fillet weld size to 1/8", handrail and top rail fillet weld size to 1/4", and base plate fillet weld size to 3/8".	5207	1 of 1	Added "POST LENGTH WITH CAP" column, BARS D, P5 thru P8 to table and bar bending details for corner posts.
	5 of 5	Added DETAIL "F" and note (*) to ANCHOR BOLT TABLE. Changed Pedestrian and Bicycle Railing designation. Corrected height dimension on steps to top of nosing.	5210	1 of 1	New Index added "PRECAST SOUND BARRIERS-PRECAST POST CAPITAL".
861	1 of 2	Changed designation of 54" tall railing to "Special Height Bicycle Railing".	5211	2 of 5	Changed NAME, DATE AND BRIDGE NUMBER note, and "Ribbed" to "Slotted" in NEOPRENE DIAPHRAGM PLUG DETAIL. Added REFLECTIVE RAILING MARKERS note and SELECTIVE RAILING MARKER SPACING table.
	2 of 2	Added requirement for set screw to be set flush against outside face of rail and 18-8 Alloy option in DETAIL "B". Changed field splice joint tolerance to 1/4" and "Steel Sleeve" to "Aluminum Sleeve" in DETAIL "B".	5212	3 of 3	Changed "Ribbed" to "Slotted" in NEOPRENE DIAPHRAGM PLUG DETAIL. Corrected Anchor Pin diameter on FIRE HOSE ACCESS DETAIL.
870	1 of 5	Deleted Pedestrian and Bicycle designations from DESIGN LIVE LOADS and ALTERNATE DESIGN notes.	5300	2 of 2	Added note for "Full Depth Structural Asphalt" above junction slab and changed coping dimension to 6" Min.
	2 of 5	Deleted 4'-6" Bicycle Railing option and "*" note. Changed maximum ramp length for slopes less than 6.25%.		3 of 19	Increased max. gap at back of precast coping and added timber blocking.
	3 of 5	Deleted 4'-6" Bicycle Railing option.		6 of 19	Added note for "Full Depth Structural Asphalt" above junction slab and increased max. gap at back of precast coping.
	4 of 5	Added requirement for set screw to be set flush against outside face of rail and 18-8 Alloy option in DETAILS "D" & "E"; and 1/4" joint tolerance in DETAIL "D". Deleted Intermediate Rails from DETAILS "B" and "C".		7 of 19	Added note for "Full Depth Structural Asphalt" above junction slab.
	5 of 5	Added DETAIL "F". Deleted 4'-6" Bicycle Railing option. Corrected height dimension on steps to top of nosing.	11200	12 & 15 of 19	Increased max. gap at back of precast coping. Corrected size of Bar 5U1 in BILL OF REINFORCING TABLE
880	1 of 5	Deleted Pedestrian and Bicycle designations from DESIGN LIVE LOADS and ALTERNATE DESIGN notes.		1-2 of 2	Deleted sheet 2
	2 of 5	Deleted 4'-6" Bicycle Railing option and "*" note. Changed maximum ramp length for slopes less than 6.25%.		1 of 2	Revised and rearranged notes, sheet renumbered to 1 of 2.
	3 of 5	Deleted 4'-6" Bicycle Railing option.	11300	2 of 2	Renumbered sheet 3 of 3 to sheet 2 of 2 revised and rearranged notes. Deleted "Class 1 (Special) Concrete" replaced with "Class 1 Concrete".
	4 of 5	Added requirement for set screw to be set flush against outside face of rail and 18-8 Alloy option in DETAILS "D" & "E"; and 1/4" joint tolerance in DETAIL "D". Deleted Intermediate Rails from DETAILS "B" and "C".	11310	1 of 1	Hanger table values revised; connection bolt size revised; sign depth for horizontal splice changed to 10'. U-Bolt material spec (A325) added to Typical Detail of Sign & Truss Connection.
	5 of 5	Added DETAIL "F". Deleted 4'-6" Bicycle Railing option. Corrected height dimension on steps to top of nosing.	11320	1 of 5	Deleted A307 bolts and Palnut (Note 4e). Changed foundation concrete (Note 7). Changed to 1/2" mesh (Note 9). Deleted grout pad and notes (former Notes 7c & 9). Added CSL tube note (Note 14).
5100	2 of 2	Changed to plastic sleeve expansion joint and "Premoulded Expansion Material" to "Preformed Joint Filler". Changed wall and expansion joint key.		2 of 5	Changed foundation standoff distance and changed drilled shaft detail. Deleted grout pad and added wire screen. Added CSL tubes. Changed FC & FL reinforcing.
5200	1 of 1	Post caps added to note C.1.b; Changed note K.2 to allow 8 ft height panels. Added note K.11; Changed notes H.1, H.2 and D.2; Deleted note H.3.		5 of 5	Changed bolt spacing connection details.
5201	1 of 1	Texture Type "I" (Cut Coral Block) added.		1 of 5	Deleted A307 bolts and Palnut (Note 4e). Changed foundation concrete (Note 7). Changed to 1/2" mesh (Note 9). Deleted grout pad and notes (former Notes 7c & 9). Added CSL tube note (Note 14).
5202	1 of 4	Added precast post cap; Changed clearance tolerance on stepped panel and Neoprene Pad options.		2 of 5	Changed foundation standoff distance. Deleted grout pad and added wire screen.
	3 of 4	Changed #4 Bar Mark to Bars P5 and P6 for Pile/Post Options A, B, & E; changed Texture Thickness to 1 1/4" Max.		4 of 5	Changed bolt spacing connection details.
5203	1 of 5	Added precast post cap; Changed clearance tolerance on stepped panel and Neoprene Pad options.		5 of 5	Changed drilled shaft detail. Added CSL tubes.
	3 of 5	Changed #4 Bar Mark to Bars P5 & P6 for Pile/Post Options A, B & E, and changed texture thickness dimension to 1/4" Max.	11860	1 of 8	Changed SINGLE COLUMN GROUND SIGN NOTES, Note 11, and GUIDE TO USE THIS STANDARD, Note 4 and example. Modified concrete classification. Modified "ALUMINUM COLUMN (POST) SELECTION TABLE".
	4 of 5	New sheet added for 45 degree corner post.		2 of 8	Changed maximum limits of sign cluster area and width in NOTE.
	5 of 5	Renumbered from Sheet 4 of 4.		3 of 8	Added Aluminum Soil Plate details and notes. Changed Post and Foundation Table depth values. Modified "ALUMINUM COLUMN (POST) SELECTION TABLE".
				4 of 8	Deleted "Signs at 90°" note. Added "For" note. Changed number of Z-brackets for STOP and RECTANGULAR sign. Changed '1" Min.' to '0" Min.' and sign panel edge distance in VIEW A-A. Modified U-bolt size. Changed panel overhang length.
				5 of 8	Modified "DRIVEN POST DETAIL IN CONCRETE".
			17302	1 of 1	CASE II, and CASE VIII dimensions and notes revised.
			17328	1 of 1	Weigh Station and combination Weigh Station and Inspection Station signing details separated.

**Revisions  
Design Standards 2010**

<b>Index Number</b>	<b>Sheet Number</b>	<b>Description</b>	<b>Index Number</b>	<b>Sheet Number</b>	<b>Description</b>
17344	2, 3, 4 & 6 of 6	SCHOOL SIGNS AND MARKINGS, on each sheet, in the Distance table at the bottom of the sheet, deleted the "A" column. Also deleted the "A" dimension from the detail drawings.	17725	1 of 2	Round pole note revised; pole height dimensions added to Type P-III through P-VIII; Copper Ground note changed.
17345	2 of 4	NORMAL TAPERED ENTRANCE WITH ADDED LANE, note in lower left corner, arrow now points to the reflective markers on the LEFT side of the ramp.		2 of 2	Notes revised and rearranged, D(feet) changed to H(feet) in both tables.
	4 of 4	Deleted note 2	17727	1-2 of 2	Schedule 40 aluminum pipe (T6061) added as an alternate to stainless steel pipe in assembly details and signalhead notes. Added backplates to signalhead details.
17346	1-14 of 14	Completely revised and renumbered.	17736	1 of 1	Added notes 5 & 6.
17347	1-4 of 4	New Index BICYCLE MARKINGS added.	17743	1 of 3	Updated assembly dimensions. Changed drilled shaft reinforcing.
17349	1 of 1	Case I and Case II revised; 18" x 18" marker detail revised; notes at bottom right revised.		2 of 3	Updated assembly dimensions. Changed drilled shaft reinforcing. Changed T3-BF.
17355	1 of 11	Revised signs FTP-9A-06 & FTP-9B-06 and notes.		3 of 3	Updated assembly dimensions. Changed drilled shaft reinforcing.
	7 of 11	For all signs with 1-800 phone number, deleted "1-800-998-RIDE" and substituted "1-8XX-XXX-XXXX" and below each sign added note: "Design Project Manager or Transit Administrator will supply correct 1-8XX number".	17745	1 of 5	QPL requirements added in new note 17; added backplates to pole detail; Notes 6 & 14 revised, deleted note 19.
	8 of 11	Revised sign FTP-68A-06, bolt holes located outside of sign message, notes revised. Sign FTP-69-06 and FTP-68B-06 message and spacing revised.	17748	2 of 5	Revised foundation reinforcing details, Section AA, Section DD and Foundation Plan details.
	9 of 11	Revised sign FTP-82-08 and arrow detail. Added Sign FTP-83-08.		1 of 1	Option 1 deleted and Options 2 and 3 renumbered; Note 1 revised. Added backplates to signalhead displays.
17356	1 of 1	Removed signalhead from detail. Single point attachment details deleted from Index. (Deleted sheet 1.)	17784	1 of 2	Dimensions revised on Figures A & B. Note 5 and Note to Designers revised.
17359	1 of 2	Changed delineators to object markers; revised reference notes; sign W13-1 made optional. RURAL NARROW BRIDGE TREATMENT, changed the DM3L on the right side of the roadways to an DM3R.	17890	2-3 of 3	Added backplates to signalhead displays.
	2 of 2	Notes revised; inserts reorganized	17900	7 of 7	Changed pole type callouts, deleted "N-III" and substituted "P-III".
17500	1 of 3	Deleted concrete pole detail, added METAL POLE DETAIL AND WIRING DIAGRAM.	18111	1-2 of 2	Index totally revised.
	2 of 3	Note 7, deleted "class I Concrete (Miscellaneous)" replaced with "Concrete and reinforcing for slabs around poles and pullboxes shall be included in the price for pullbox or pole."	18113	1-2 of 2	Index totally revised.
	3 of 3	Note 7, deleted "class I Concrete (Miscellaneous)" replaced with "Concrete and reinforcing for slabs around poles and pullboxes shall be included in the price for pullbox or pole."	20110	1 of 1	Changed Insert Detail for Diaphragm Reinforcing.
17501	1 of 1	Deleted note 28.	20199	1 of 1	Changed BEAM CAMBER AND BUILD-UP NOTES.
17502	3 of 7	Changed Note 9. Added Notes 10 & 11. Changed Notes 11 & 12. Deleted grout pad notes (former Notes 4 & 9). Added CSL tube note (Note 11).	20210	2 of 2	Added "Type Q" Epoxy to Note 9.
	4 of 7	Added ID plate and changed base plate thickness. Deleted grout pad. Changed drilled shaft reinforcing.	20299	1 of 1	Changed BEAM CAMBER AND BUILD-UP NOTES.
	5 of 7	Changed Weld symbol in SECTION A-A. Added padlock tab to HANDHOLE RING. Added Section E-E detail and bottom baseplate washer to SECTION C-C. Deleted grout pad and added wire screen. Added CSL tubes.	20500	1 of 1	Added Type C Pads for larger skew ranges. Changed specification of elastomer from "durometer" to "shear modulus".
	6 of 7	Grout notes and details removed, new wire screen.	20501	1 of 1	Changed Note 4.
	7 of 7	Note 3, changed "Concrete class" to "concrete NS"	20502	1 of 1	Changed Note 4.
17503	1 of 1	Index deleted.	20602	1 of 1	Changed EDC location to 1D from tip of pile.
17504	1 of 1	Dimensions 5'-6" added for height of meter base. Pole type changed from type "N" to type "P".	20900	2 of 2	Changed coping width and End Bent lug from 6" to 5½" thickness.
17505	1 of 2	Mercury Vapor Luminaires changed to Induction Luminaires. Luminaire chart deleted, dimensions revised on spacing detail note and added to structure detail.	20910	2 of 2	Changed coping width and End Bent lug from 6" to 5½" thickness.
17515	1 of 8	Added median barrier mounted light poles. Moved notes to sheet 2.	21100	1 of 3	Deleted redundant notes from Specification Section 458.
	2 of 8	New Sheet for Notes. Change Note 7 for QPL Criteria. Modified concrete classification. Added notes for median barrier mounted light pole and foundation.		3 of 3	Changed Sidewalk Cover Plate edge treatment.
	3 of 8	Sheet renumbered from 2 to 3. Added double arm configuration to ARM ELEVATION.	21110	1 of 2	Deleted redundant notes from Specification Section 458. Changed last line of title of bottom left detail to "DECK WITH SLOPES 2% OR GREATER".
	4 of 8	Allowed fusion weld reinforcing cage (*) and changed foundation concrete note. Added 1" dimension to Double Nuts in FOUNDATION. Modified concrete classification. Renumbered sheet from 3 of 3 to 4 of 8.		2 of 2	Changed Sidewalk Cover Plate edge treatment.
	5-8 of 8	New Sheets for median barrier mounted light pole.	21200	1 of 2	Added "Anchor Plate (dashed lines) (provide Design) to ELEVATION VIEW and TYPICAL SECTION. Added design of anchor bolts and accessories.
17600	2 of 3	Added detail for pole foundation to be used only behind guardrail.		2 of 2	Added design of anchor bolts and accessories.
	3 of 3	GENERAL NOTES, note 2, changed "Class II Concrete" to "Class I Concrete"; changed note 4.	21600	1 of 7	Clarified INSTRUCTIONS TO DESIGNER for variable end span lengths.
17723	1 of 3	Changed Note 5i, 6 and 7. Added Note 8. Deleted grout pad and notes (former Notes 4d & 7). Added CSL tube note (Note 9).		3 of 7	Added vertical dimensions between deck surface and underside of bearings, including depth of Truss Panel.
	2 of 3	Changed number of bolts in VIEW B-B, number and size of foundation reinforcing bars, and TABLE OF STRAIN POLE VARIABLES. Added foundation standoff distance and washer for base plate. Deleted grout pad and added wire screen. Added CSL tubes. Changed drilled shaft reinforcing.	21802	1 of 1	Changed "Methyl Methacrylate" to "High Molecular Weight Methacrylate".
	3 of 3	Changed note in VIEW E-E; Added ¼" and ⅜" cable clamps and changed weld criteria. Changed clevis size.	21803	1-2 of 3	Revised call-outs for Grout Outlets; Changed "Methyl Methacrylate" to "High Molecular Weight Methacrylate".
				3 of 3	Shrink wrap deleted from Duct Coupler Detail. Revised call-outs for Duct Couplers; Changed "Methyl Methacrylate" to "High Molecular Weight Methacrylate".

A Area or Amperes  
AAA American Automobile Association  
AADT Annual Average Daily Traffic  
AASHTO American Association Of State Highway Officials  
AASHTO American Association Of State Highway And Transportation Officials  
ABC Asphalt Base Course  
Abd. Abandoned  
ABS Acrylonitrile-Butadiene-Styrene Pipe  
AC, Ac. Acre  
AC or Asph. Conc. Asphaltic Concrete  
Accel. Acceleration  
ACI American Concrete Institute  
Act. Actuated  
ADA The Americans With Disabilities Act  
Adh. Adhesive  
Adj. Adjust  
ADT Average Daily Traffic  
AFAD Automatted Flagger Assistance Device  
Agg. Aggregate  
Ah. Ahead  
AISC American Institute Of Steel Construction  
Alt. Alternate  
Al. Aluminum  
AM 12:00 Midnight Until 11:59 Noon  
ANSI American National Standards Institute  
ADS Apparent Opening Size  
Appl.. Applied, Application  
Apprh. Approach  
Approx. Approximate  
ARTBA American Road & Transportation Builders Association  
Artf. Artificial  
Asph. Asphalt  
Assem. Assembly  
Assn. Association  
Assoc. Associate, Association  
ASTM American Society For Testing And Materials  
ATPB Asphalt Treated Permeable Base  
Attn. Attention  
Attnuatr. Attenuator  
Aux. or Auxil. Auxiliary  
Ave. Avenue  
AWG American Wire Gauge  
AWS American Welding Society  
Az Azimuth

B to B Back to Back  
Basc. Bascule  
Bd. or Bnd. Bond or Bonded  
BC Bottle Cap or Bolt Circle  
B/C, B.C. Back Of Curb  
BCCMP Bituminous Coated Corrugated Metal Pipe Culvert  
BCPA Bituminous Coated Pipe Arch Culvert  
BCPCMP Bituminous Coated And Paved Corrugated Metal Pipe Culvert  
BCPPA Bituminous Coated And Paved Pipe Arch Culvert  
BCT Breakaway Cable Terminal  
BCWE Base Clearance Water Elevation  
BE Buried Electric  
Beg. Begin  
Bit. Bituminous  
Bk. Back  
BL, BLC, or B Base Line, Base Line Control  
Bldg. Building  
Blkhd. Bulkhead  
BLDN Begin Length Of Need  
Blvd. Boulevard  
BM Bench Mark  
Bndry. Boundary  
Bdr. Border  
Bot. Bottom  
BO Basin Outlet  
BOS Beginning Of Survey  
BP Borrow Pit  
Bq. Becquerel

Br. Bridge  
Brg. Bearing  
Brkwy. Breakaway  
BT Buried Telephone Cable or Duct  
Btfly. Butterfly  
BW Barbed Wire, Bottom Width or Both Ways  
C Cantilever Length, Cut, Colorless, Coulomb or Cycle Length  
°C Degree Celsius  
C & G Curb And Gutter  
CA Coarse Aggregate  
Cap. Capacity  
CAP Corrugated Aluminum Pipe  
Caps. Capital Letters  
CASP Corrugated Aluminized Steel Pipe  
CATV Cable Television  
CB Catch Basin  
CBC Concrete Box Culvert  
CBS Concrete Box Structure  
CC, C/C, C to C, or C.C. Center to Center, Crash Cushion  
CCEW Center to Center Each Way  
CCTV Closed-Circuit Television  
CD Cross Drain, Cross Direction (Geotextiles)  
cd Candela  
Cem. Cement or Cemetery  
Cem'd. Cemented  
CFS Cubic Feet Per Second  
Ch. Channel  
Chchg. Channel Change  
Chg. Changeable  
CI Cast Iron  
CIP Cast Iron Pipe  
CIPL, C.I.P., C-I-P Cast In Place  
circ. Circumference  
Ckt. Circuit  
Cl. or Clear Clearance  
CL, C/L or C Center Line  
CM Concrete Monument  
CMB Concrete Median Barrier  
CMP Corrugated Metal Pipe  
CMPA Corrugated Metal Pipe Arch  
Co. County or Company  
Col. Column  
Com. Commercial or Common  
CDMM Committee or By Committee  
Comp. Composite  
Con. Connect or Connection  
Conc. Concrete  
Const. Construct or Construction  
Contrl. Controller  
Cont. Continuation  
Contr. Contractor  
Coord. Coordinate  
Cor. Corner  
Corr. Corrugated  
CP Concrete Pipe  
CPE Corrugated Polyethylene Pipe  
CPT Cone Penetration Test  
CR Control Radius or County Road  
CRA Clear Recovery Area  
Crs. or Cse. Course  
CS Curve To Spiral  
CSP Corrugated Steel Pipe  
CT Clear Trunk  
CTPB Cement Treated Permeable Base  
Ctivr. Cantilever  
Ctr., Ctrs. Center  
CU or Cu Copper  
Culv. Culvert  
Cwt. Hundredweight  
CY, Cu. Yd., CY, or C.Y. Cubic Yard  
Cyl. Cylindrical

D Degree Of Curvature, Depth, Density, Distance, Diameter or Directional Distribution  
DA Drainage Area or Deflection Angle  
DBH Diameter At Breast Height  
DBI Ditch Bottom Inlet  
Dbl. Double  
DCS Degree Of Curvature (Spiral)  
DD Dry Density  
DDHV Directional Design Hour Traffic  
Decel. Deceleration  
Deg. Degree  
Delin. Delineators  
Demobl. Demobilization  
Dept. Department  
Det. Detour, Detection, Detectable  
DFE Design Flood Elevation  
DGN or Dgn. Design  
DHV Design Hourly Volume  
DHW Design High Water  
DT Ditch  
DI Drop Inlet  
Dia. or D Diameter  
Dim. Dimension  
Disp. Disposal  
Dist. Distance  
DLS District Location Surveyor  
DMM Domestic Mail Manual  
DOT Department Of Transportation  
DPI or D.P.I. Ditch Point Intersection  
Dr. or DR. Drain, Drive or Design Review  
DR Design Review  
Driv. Driven  
Drwy. Driveway  
DS Design Speed  
DSL Design Service Life  
Dwg. Drawing  
E East or External Distance  
e Rate Of Superelevation  
E to E End to End  
EA or Ea. Each  
EB Eastbound  
EIA Electronic Industries Alliance  
El. or Elev. Elevation  
Elast. Elastomeric  
Elec. Electric  
Ellip. Elliptical  
Embk. Embankment  
Emul. Emulsified  
Encl. Enclosure  
Engr. Engineer  
EOS End Of Survey or Equivalent Opening Size  
E.P. or EOP Edge Of Pavement  
EPDM Ethylene Propylene Diene Monomer  
Eq. Equation or Equal  
Equip. Equipment  
Esmt. Easement  
Est. or Estm. Estimate  
Est. Establish or Established  
Etc. or etc. Et Cetera (And So Forth)  
ETP Electronic Tough Pitch  
EW Endwall  
Ex. Except, Example  
Exc. or Excav. Excavation  
Exist. Existing  
Exp. Expansion  
Ext. Extension  
Exwy. Expressway

The abbreviations listed are the standard for contract plans production. This list is not all inclusive. Other Department accepted abbreviations may be used when deemed more appropriate. Where special abbreviations are used a descriptive tabulation may be necessary in the plans.



2010 FDOT Design Standards

**STANDARD ABBREVIATIONS**

Last Revision	Sheet No.
07/01/09	1 of 3
Index No.	
001	

F	Fill, Farad	HW or H.W.	High Water or Hot Water	M	Mass, Middle Ordinate Length or Mega	N m	Newton Meter
F or Final	Final Quantity	Hwy.	Highway	m	Meter or Milli	No.	Number
F & I	Furnish & Install	Hyd.	Hydraulic	m <sup>2</sup>	Square Meter or Meter Square	Nom.	Nominal
F to F	Face to Face	Hz	Hertz	m <sup>3</sup>	Cubic Meter or Meter Cubed	Norm.	Normal
FA	Federal Aid or Fine Aggregate			m <sup>3</sup> /m	Cubic Meter Per Meter	N.P.	Non Plastic
FAC	Florida Administrative Code	I	External Angle (Delta), Interstate	m/s	Meters Per Second	NPS	Nominal Pipe Size
FAP	Federal Aid Project	Intchg. or Ichg.	Interchange	Mach.	Machine	NPT	National Pipe Thread
FC	Friction Course	IES	Illuminating Engineering Society	Maint.	Maintenance	NRCP	Non-Reinforced Concrete Pipe
FD	French Drain	ID, I.D.	Inside Diameter or Identification	Matl.	Material	NS	Non Stress, Not Suitable or Near Side
Fdn.	Foundation	IMC	Intermediate Metal Conduit	Max.	Maximum	NT, N&T	Non Traffic, Nail & Tin
FDDT	Florida Department Of Transportation	In.	Inch or Inches	MB	Median Barrier	NTS	Not To Scale
FE	Floor Elevation	Inc.	Incorporated or Including	MBM	Thousand (Feet) Board Measure	NW	Northwest
Fed.	Federal	Incl. or Inc.	Included	MD	Machine Direction (Geotextiles)		
Fert.	Fertilizer	Ind.	Industry or Industrial	Med.	Median	Opass	Overpass
FES	Flared End Section	INV. or Inv.	Invert	Mega	One Million	Q to Q, o to o or O.D.	Out to Out
FETS	Flared End Terminal Section	IP	Iron Pipe	Memb.	Member	QA	Overall
FH	Fire Hydrant	Install.	Installed	MES	Mitered End Section	Q.B.G.	Optional Base Group
FHWA	Federal Highway Administration	Isect.	Intersection	Mess.	Message	QC or Q.C.	On Center
Fig.	Figure	Isl.	Island	Mfg.	Manufactured or Manufacturer	OD or O.D.	Outside Diameter
Fin.	Finish	IR	Iron Rod	MG	1000 Gallons	OE	Overhead Electric
F.L., FL or $\bar{F}$	Flow Line	ITE	Institute Of Transportation Engineers	MH, M.H.	Manhole, Mounting Height	OH, OHD or Ohd.	Overhead
FL, Fl. or Fla.	Florida	ITS	Intelligent Transportation Systems	MHW	Mean High Water	Opt.	Option, Optional or Optically
Flex.	Flexible			$\mu$	Micro	OT	Overhead Telephone
FNQ	Fuse (Type Slow Burn)	J	Joule	Mi.	Mile	Oz.	Ounce
FDC	Fiber Optics Cable	JB	Junction Box	Micro	One-Millionth	$\Omega$	Ohm
FPM or fpm	Feet Per Minute	Jct.	Junction	Mid.	Middle	P	Passenger Car & Light Delivery Truck
FPS or fps	Feet Per Second	Jt.	Joint	Mil	One-Thousandth Of An Inch	P or Plan	Plan Quantity
FR or Fr.	Frame			Mil.	Military	Pa	Pascal
Frang.	Frangible	K	Design Hour Factor or Kelvin	Milli	One-Thousandth	Par.	Parallel
Freq.	Frequency	k	Kilo (prefix)	Min.	Minimum or Minute	Pa.s	Pascal Second
F.S.	Florida Statutes	kg	Kilogram	Misc.	Miscellaneous	Part.	Participation or Partition
Ft.	Foot or Feet	kg/m	Kilogram Per Meter	mL	Milliliter	Pavt.	Pavement
FTB	Floating Turbidity Barrier	kg/m <sup>2</sup>	Kilogram Per Square Meter	MLW	Mean Low Water	PC	Point Of Curvature
FTBA	Florida Transportation Builder Association	kg/m <sup>3</sup>	Kilogram Per Cubic Meter	mm	Millimeter	PCBC	Precast Concrete Box Culvert
FTP	Florida Traffic Plans	Kilo	One Thousand	mobl.	Mobilization	PCC	Point Of Compound Curvature or Plain Cement Concrete
Furn.	Furnish	Kip	1000 Pounds	Mod.	Modify or Modified	PCE	Permanent Construction Easement
		km	Kilometer	Mol	Mole	PE	Professional Engineer
		km/h	Kilometer Per Hour	Mon.	Monument	Ped	Pedestrian or Pedestal
G	Giga or Gauss	kn	Knot	MOT	Maintenance Of Traffic	Pen.	Penetration
g	Gram or Gravity	kN	Kilonewton	MP	Mile Post	PG	Profile Grade
Galv.	Galvanized	kPa	Kilopascal	MPa	Megapascal	PGL	Profile Grade Line
Ga.	Gauge or Gage	ksi	Kips Per Square Inch	MPH or mph	Miles Per Hour	Ph.	Phase
Ga. or Gal.	Gallon	kV	Kilovolt	MSL	Mean Sea Level	pH	Measure Of Acidity or Alkalinity
Gar.	Garage	kVA	Kilovolt Ampere	MSTCSD	Minimum Specifications For Traffic Control Signal Devices	PI	Point Of Intersection
GD	Gutter Drain	kWh	Kilowatthour			Pkg.	Parking
GFI	Ground Fault Interrupter			Mtd.	Mounted	Pkgwy.	Parkway
GIP	Galvanized Iron Pipe	L	Length, Length Of Curve, Liter, Left	MUTCD	Manual On Uniform Traffic Control Device	PL or $\bar{P}$	Property Line or Plate
GM	Gas Main	2-L	Two-Lane	MUTS	Manual On Uniform Traffic Studies	PM	12:00 Noon Until 11:59 Midnight
GP	Grade Point	2L1W	Two-Lane One-Way			POC	Point On Curve
Gr.	Grade, Guardrail or Grate	2L2W	Two-Lane Two-Way	N	North or Newton	PDST	Point On Semi-Tangent
Gr. or Gro.	Gross	LA or L/A	Limited Access	N/m	Newtons Per Meter	POT	Point On Tangent
GRC	Galvanized Rigid Steel Conduit	Lat.	Lateral or Latitude	N/m <sup>2</sup>	Newtons Per Square Meter	PP	Power Pole
Grd.	Ground	Lb.	Pound	N/m <sup>3</sup>	Newtons Per Cubic Meter	PPB	Pier Protection Barrier
GRI	Geosynthetic Research Institute	LBS.	Pounds	N/mm <sup>2</sup>	Newtons Per Square Millimeter	Pr.	Pair
gross km	Gross Kilometer	lb/sy	Pounds Per Square Yard	NA or N/A	Not Available or Not Applicable	PRC	Point Of Reverse Curvature
Gr. Wt. or gr. wt.	Gross Weight	LBR	Limerock Bearing Ratio	N & C	Nail & Cap	Prct.	Precast
Gttr.	Gutter	LC	Long Chord	N & D	Nail & Disk	Prest.	Prestressed
		LED	Law Enforcement With Flashing Lights And Radar	NAVD	National American Vertical Datum	Prob.	Probability
H	Henry	LFD	Load Factor Design	NB	Northbound	Prod.	Product, Production, Producer or Produced
h	Hour or Hecto	Lgth.	Length	NC	National Coarse or Normal Crown	Prog.	Program or Progression
ha	Hectare	Lin.	Linear	NCHRP	National Cooperative Research Program	Proj.	Project or Projection
HAR	Highway Advisory Radio	lm	Lumen	NDCBU	Neighborhood Delivery And Collection Box Unit	PRM	Permanent Reference Monument
HB	Hay Bales	Lmrk.	Limerock	NE	Northeast	Prop.	Proposed
HC	Horizontal Clearance	LDS	Limit Of Clear Sight	net km	Net Kilometer	Prov.	Provisions
HD	High Density or Heavy Duty	Loc., LD	Location	NEMA	National Electrical Manufacturers Association	PRS	Portable Regulatory Sign
HD or Hd.	Head	Long.	Longitude	NGVD	National Geodetic Vertical Datum of 1929	PS & E	Plans, Specifications And Estimates
HDPE	High Density Polyethylene	LRFD	Load Resistance Factor Design	NGS	National Geodetic Survey	PSF or psf	Pounds Per Square Foot
Hdl.	Headwall	LS	Length Of Spiral	NHS	National Highway System	PSI or psi	Pounds Per Square Inch
HH	Heavy Hex	LT	Left Turn	NHW	Normal High Water	PT	Point Of Tangency or Pressure Treated
Hndrl	Handrail	Lt.	Left	NIC	Not In Contract	PVC	Polyvinyl Chloride
HDA	Hand/Off/Automatic	Ltd.	Lighted or Limited	NJ	New Jersey	PW	Pressure Water
Horiz. or Hor.	Horizontal	Lum.	Luminaire				
HP	High Pressure or Horsepower	L/W	Lightweight				
Hr.	Hour	lx	Lux				
HS	High Strength						
HSHV	High Strength Horizontal Vertical						
Hse.	House						
Ht.	Height						

The abbreviations listed are the standard for contract plans production. This list is not all inclusive. Other Department accepted abbreviations may be used when deemed more appropriate. Where special abbreviations are used a descriptive tabulation may be necessary in the plans.



2010 FDOT Design Standards

**STANDARD ABBREVIATIONS**

Last Revision	Sheet No.
07/01/09	2 of 3
Index No.	
001	



Q Peak Discharge or Flow Volume  
 QPL Qualified Products List

R Right  
 R or Rad. Radius  
 R or Rng. Range  
 rad Radian  
 rad/s Radian Per Second  
 RBAC Rock Base Asphaltic Concrete  
 RBST Rock Base Surface Treatment  
 RC Reverse Crown  
 RCP Reinforced Concrete Pipe  
 RCPA Reinforced Concrete Pipe Arch  
 Rd. Road or Round  
 Rdsd. Roadside  
 Rdwy. Roadway  
 Rec. Recovery  
 Rect. Reticuline or Rectangular  
 Ref. Reference  
 Refl. Reflective  
 Reg. Region, Regular, Registered or Regulation  
 Reinf. Reinforced or Reinforcing  
 Rejuv. Rejuvenation  
 Reloc. Relocated  
 Rem. Removal  
 Repl. Replace  
 Req. or Reqd. Required  
 Res. Residence or Residential  
 RGS Rigid Galvanized Steel  
 RHW Insulation (Moisture & Heat Resistant Rubber)  
 RM Reference Monument  
 r/min Revolution Per Minute  
 RP Reference Point  
 rpm Revolution Per Minute  
 RPM Raised Reflective Pavement Markers  
 r/s Revolution Per Second  
 RR Railroad  
 RSDU Radar Speed Display Unit  
 Rsf. Resurface  
 Rt. Right  
 RU Rack Unit  
 R/W, RDW Right Of Way  
 RX Receive

S or s Speed, South, Siemens, Or Second  
 SAHM Sand-Asphalt Hot Mix  
 SAN or San. Sanitary  
 SB Southbound  
 SBAC ShellBase Asphaltic Concrete  
 SBRM Sand Bituminous Road Mix  
 SBST ShellBase Surface Treatment  
 SC Seal Coat or Spiral To Curve  
 Sch. Schedule  
 SCST Sand-Clay Surface Treatment  
 SD Side Drain, Storm Drain  
 SE Southeast  
 Sec. Second  
 Sect. Section  
 Sed. Sediment  
 Sep. Separator  
 Seq. Sequential  
 Serv. Service  
 SF Adjustment Factor In Percent, Silt Fence  
 SG Subgrade  
 SG Specific Gravity  
 Sh. or Sht. Sheet  
 Shldr. Shoulder  
 SHW Seasonal High Water  
 SIP Stay In Place  
 SP Superpave  
 Spa. Space  
 Spcg. or Sp. Spacing  
 Spec. Specification  
 SPT Standard Penetration Test  
 Sq. Ft., SF, or S.F. Square Foot  
 Sq. In. Square Inch  
 Sq. Yd., SY or S.Y. Square Yard  
 SR or S.R. State Road  
 SRAP Spiral Rib Aluminum Pipe

SRASP Spiral Rib Aluminized Steel Pipe  
 SRCP Steel Reinforced Concrete Pipe  
 SRD State Road Department  
 SRSP Spiral Rib Steel Pipe  
 SS Sanitary Sewer  
 SSMD Solid State Modular Design  
 ST Surface Treatment or Spiral To Tangent  
 St. or ST. Street  
 Sta. Station  
 Stab. Stability or Stabilization  
 STB Staked Turbidity Barrier  
 Std. Standard  
 Stg. Strong  
 Stge. Storage  
 Stl. Steel  
 Str. Structure  
 Sty. Story  
 SU Single Unit Trucks  
 Sub. or Subs. Subsoil  
 Sub. or Subst. Substitute  
 Subgr. Subgrade  
 Suppts. Supports  
 SUR or Sur. Survey  
 Surf. Surface  
 SW Southwest  
 SW or Swk. Sidewalk  
 Sys. or Syst. System  
 Sv Sievert  
 Sym. Symmetrical

T Tangent, Length Of Curve, Percent Trucks, Tesla,  
 T, TWP or Twp. Township  
 t Metric Ton  
 tan. Tangent  
 TBM Temporary Bench Mark  
 TC Tangent To Curve  
 TCB Temporary Concrete Barrier  
 TCE Temporary Construction Easement  
 TCP Terra Cotta Pipe  
 TCZ Traffic Control Zone  
 TDLC Transportation Design For Livable Communities  
 Tel. Telephone  
 Temp. Temperature or Temporary  
 Theo. Theoretical  
 THRMPLSTC Thermoplastic  
 THW or THWN Insulation (Flame Retardant, Moisture And Heat Resistant Thermoplastic)  
 Thick. Thickness  
 Tk Thick, Thickness or Truck  
 Tn. Ton  
 Traf. Traffic  
 Trans. Transition, Transverse, Translate or Transportation  
 Treat. Treatment  
 TS Tangent To Spiral  
 TSC Length Of Tangent (Spiral Curve)  
 TTC Temporary Traffic Control  
 TVSS Transient Voltage Surge Suppression  
 TX Transmit  
 Typ. Typical

Upass. Underpass  
 UG Underground  
 UL Underwriters Laboratories  
 Ult. Ultimate  
 Unltd. Unlimited  
 Unddr. Underdrains  
 Undrdwy. Underroadway  
 UNL or Undl. Unloaded  
 Untr. Untreated  
 UPS Uninterruptible Power Supply  
 USC & GS US Coast and Geodetic Survey (now National Geodetic Survey)  
 USGS US Geological Survey  
 USPS United States Postal Service  
 Util. Utilities  
 UV Ultraviolet

V Volt, Velocity, Volume or Hourly Volume  
 Var. Varies, Variable or Variance  
 VC Vertical Curve  
 VCP Vitrified Clay Pipe  
 VECP Value Engineering Change Proposal  
 Veh. Vehicle  
 Vert. Vertical  
 VF Vertical Foot  
 Vh Verified Horizontal Location  
 VMS Variable Message Sign  
 Vol. Volume  
 VP Vertical Panel  
 VPD or Vpd. Vehicles Per Day  
 VPH or Vph. Vehicles Per Hour  
 VPHPL or Vphpl. Vehicles Per Hour Per Lane  
 VRMS Volts Root Mean Square  
 Vv Verified Vertical Elevation  
 Vvh Verified Vertical Elevation And Horizontal Location  
 VW Variable Width

W Width, Wide, West or Watt  
 W/C Water-Cement Ratio  
 WB Westbound  
 Wb. Weber  
 WB40 Intermediate Semi Trailer  
 WB50 Large Semi Trailer  
 WB62 Interstate Semi Trailer  
 WB67D Tandem Semi Trailer  
 WM Water Main  
 W.P.I. Work Program Item  
 WT Water Table Or Weight  
 WWF Welded Wire Fabric  
 WWR Welded Wire Reinforcing

X Coordinate Value (East-West Direction) or Extra  
 X Rd. Cross Road  
 Xing. Crossing  
 Xsec. Cross Section

Y Coordinate Value (North-South Direction)  
 Yd. Yard  
 Yr. Year

**UNITS OF MEASURE**

US MEASUREMENT	
AC	Acre
AS	Assembly
BU	Bushel
CF	Cubic Foot
CO	Cleanout
CY	Cubic Yard
EA	Each
ED	Each Day
GA	Gallon
GM	Gross Mile
LB	Pound
LF	Linear Foot
LM	Lane Mile
LO	Per Location
LS	Lump Sum
LU	Luminaire
MB	Thousand Board Measure
MG	Thousand Gallons
MH	Man Hour
NM	Net Mile
PA	Per Analysis
PB	Per Building
PE	Pile
PI	Per Intersection
PL	Plant
PM	Per Mile
PS	Per Set
PW	Per Well
SI	Square Inch
SF	Square Foot
SY	Square Yard
TN	Ton











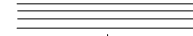

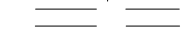
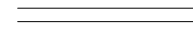

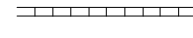
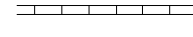

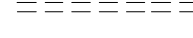
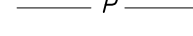
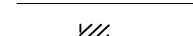

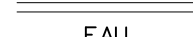

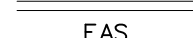
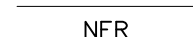
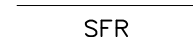
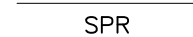

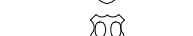
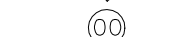
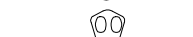



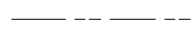
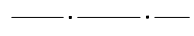
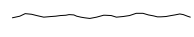
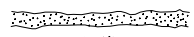







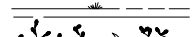
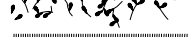





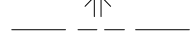
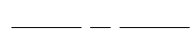

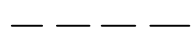
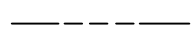



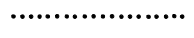
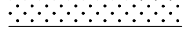
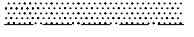
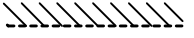
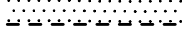
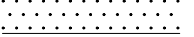





































  

METRIC MEASUREMENT	
AS	Assembly
CD	Cleanout
DA	Day
EA	Each
ED	Each Day
GK	Gross Kilometer
HA	Hectare
HR	Hour
KG	Kilogram
KL	Kiloliter
KM	Kilometer
LI	Liter
LK	Lane Kilometer
LO	Per Location
LS	Lump Sum
LS/AS	Lump Sum Per Assembly
LS/DA	Lump Sum Per Day
LS/EA	Lump Sum Per Each
LS/HA	Lump Sum Per Hectare
LS/KG	Lump Sum Per Kilogram
LS/LS	Lump Sum Per Lump Sum
LS/MT	Lump Sum Per Metric Ton
LS/MI	Lump Sum Per Linear Meter
LS/M2	Lump Sum Per Square Meter
LU	Luminaire
MH	Man Hour
MO	Month
MT	Metric Ton
M1	Meter
M2	Square Meter
M3	Cubic Meter
NK	Net Kilometer
PA	Per Analysis
PB	Per Building
PI	Per Intersection
PL	Plant
PW	Per Well

The abbreviations listed are the standard for contract plans production. This list is not all inclusive. Other Department accepted abbreviations may be used when deemed more appropriate. Where special abbreviations are used a descriptive tabulation may be necessary in the plans.



## STANDARD SYMBOLS FOR KEY MAP

 Highway With Full Control of Access  Highway With Frontage Roads  Highway Interchange  Proposed Controlled Access Highway  Divided Highway  Hard Surfaced Road  Soil, Gravel Or Shell Surfaced Road  Graded And Drained Road  Unimproved Road  Primitive Road  Private Road  Streets In Inset Or Delimited Areas  Extension Of Local Roads Within Cities  FAI Federal Aid Interstate Highway  FAU Federal Aid Urban Highway  FAP Federal Aid Primary Highway  FAS Federal Aid Secondary Highway  NFR National Forest Road  SFR State Forest Road  SPR State Park Road  Interstate Highway  US Numbered Highway  State Highway  County Road	 Free Ferry  Toll Ferry  Canal Or Drainage Ditch  Intracoastal Waterway  Narrow Stream  Wide Stream  Dam  Dam Or Spillway With Lock  Dam With Road  Flood Control Structure  Lake, Reservoir Or Pond  Intermittent Pond  Meandered Lake  Marsh Or Swamp  Mangroves  Levee Or Dike  Levee Or Dike With Road  Highway Bridge  Small Bridges Closely Spaced  Drawbridge  Highway Grade Separation  Tunnel  State Boundary Line  County Boundary Line  Civil Township Boundary  Extended Township Line  Land Grant Line  Land Section Line  State Survey Section Line  Survey By Others  Location Of Inset Boundary Within Map  Military Reservation Boundary  College Or University Boundary  Corporate Limits  Delimited Area, Population Est.  Reservation, Forest Or Park Boundary  Wildlife Refuge Boundary	 Residential Area Under Development  Lighthouse  State Capital  County Seat  Other City Or Village  Seminole Indian Village  Welcome Station  Wayside Park Or Small Park  Park With Boat Ramp  Boat Ramp  Museum  Recreational Area Or Historic Site  Scenic Site  Post Office  School  Church  Cemetery  Church And Cemetery  Hospital, Health Center Or Rest Home  Toll House, Port Of Entry Or Weight Station  Fair Grounds, Race Course Or Rodeo Arena  Mine Or Strip Mine  Governmental Research Station	 Agricultural Inspection Station  Farmers Market  Game Preserve  Game Checking Station  Bird Sanctuary  Fire Control Headquarters  Lookout Tower  Fire Station  Patrol Or Police Station  Correctional Institution Or Road Camp  Department of Transportation Facility  Coast Guard Station  Armory  Junkyard  Sanitary Fill  Sewage Disposal Plant  Incinerator  Power Plant  Power Substation  Communications Facility  Locked Gate Or Fence  Triangulation Station
--	--	--	--

### GENERAL NOTE

1. Symbols on this Index are intended for use on all Roadway, Signing And Marking, Signalization, and Lighting projects. For work zone traffic control symbols refer to Index 600. When additional or similar symbols are used, legends or notations may be required for clarity.





# STANDARD SYMBOLS FOR PLAN SHEETS

## GENERAL SYMBOLS

	State Line
	County Line
	Township Line
	Section Line
	City Line
	Base Or Survey Line
	Right-Of-Way
	Easement Line
	Limited Access Line
	Fence Line
	National Or State Park Or Forest
	Grant Line
	Railroad (Drainage Maps)
	Railroad (Detail Plans)
	Fence (Limited Access)
	Box Culvert
	Bridge
	Pipe Culvert-Mitered End Section
	Pipe Culvert-Straight Endwall
	Pipe Culvert-U-Type Endwall
	Pipe Culvert-Median Drain
	Pipe Culvert-Other End Treatments
	18" SD Storm Drain (Proposed)
	18" SD Storm Drain (Existing)
	Inlet
	Manhole
	Tied Longitudinal Joint
	Keyed Longitudinal Joint
	Doweled Transverse Expansion Joint
	Doweled Transverse Contraction Joint
	Transverse Contraction Joint Without Dowels
	Survey Reference Point
	ALACHUA Triangulation Station
	B.M. NO. 112 Bench Mark
	Point Of Intersection
	North Arrow
	Edges Of Existing Pavement And Sidewalk
	Guardrail
	c.c. Crash Cushion (Attenuator)
	Piling Pier Column
	Concrete Monument
	Base Line
	Centerline
	Flow Line
	Property Line
	Delta Angle
	Approximate
	Round Or Diameter

	Curb
	Curb And Gutter
	Water Well, Spring
	Levee
	MP 327 Railroad Mile Post
	Railroad Signal With Gate
	Railroad Switch
	Gate
	Pump Island
	Storage Tank (Surface)
	Storage Tank (Underground)
	Mine Or Quarry
	Borrow Pit
	Church
	Store
	RES Residence
	B Barn
	S School
	Synthetic Bales
	Silt Fence
	Floating Turbidity Barrier
	Staked Turbidity Barrier
	Stream
	Shore Line
	Marsh
	Wetland Boundary (Proposed)
	Wetland Boundary (Existing)
	Hedge
	Trees
	Edge Of Wooded Area
	Shrubbery
	Grove Or Orchard
	Definition Of Skew For Cross Drains And Barrels Of Concrete Box Culverts
	Rt. Skew Lt.
	Concrete
	Wood
	e Rate Of Superelevation

## UTILITY ADJUSTMENT SYMBOLS

EXISTING	PROPOSED		EXISTING	PROPOSED	
		Manhole			Water Main
		Fire Hydrant			Non Potable Water
		Meter (Type)			Sanitary Sewer
		Valve (Type)			Gas
		Valve Box (Type)			Roof Drain
		Valve Cover (Type)			Petroleum
		Vent (Type)			Steam
		Pump Station			Casing
		Sewage Pump Station			Duct
		Cleanout			Buried Electric
		Cable TV Service Box			Overhead Electric
		Power Pole			Buried Cable Television
		Telephone Pole			Overhead Cable Television
		Combination Pole			Buried Telephone
		Guy Wire And Anchor Pin			Overhead Telephone
		Guy Pole Deadman			Buried Fiber Optic
		Tower			Overhead Fiber Optic
		Light Pole			
		Transformer			

See General Note, Sheet 1 of 3



2010 FDOT Design Standards

## STANDARD SYMBOLS

Last Revision <b>07/01/09</b>	Sheet No. <b>2 of 3</b>
Index No. <b>002</b>	

# STANDARD SYMBOLS FOR PLAN SHEETS

## TRAFFIC SIGNALS SYMBOLS

EXISTING	PROPOSED	
		Traffic Signal Head (Span Wire Mounted)
		Traffic Signal Head (Pedestal Mounted)
		Traffic Signal Head (Mast Arm Mounted)
		Traffic Signal Pole (Concrete, Wood, Metal)
		Vehicle Detector (Loop)
		Signal Cable (On Messenger Wire)
		Conduit
		Vehicle Detector (Points)
		Pedestrian Detector
		Pedestrian Signal Head (Pole Or Pedestal Mounted)
		Controller Cabinet (Base Mounted)
		Controller Cabinet (Pole Mounted)
		Walk - Dont Walk
		Flashing Dont Walk
		Signal Face Number
		Signal Lens
		Programmed Signal Head
		Messenger Wire
		Pole Tabulation Cross Reference
		Pole Tabulation Cross Reference (Joint Use Pole)
		Signal Phase

## LIGHTING SYMBOLS

EXISTING	PROPOSED	
		Pole & Luminaire
		Existing Pole & Luminaire To Be Removed
		Final Position Of Relocated Or Adjusted Pole & Luminaire
		High Mast Lighting Tower
		City Or Utility Owned Luminaire & Pole
		PVC (Polyvinyl Chloride) Lighting Conduit And Conductors
		Rigid Galvanized Lighting Conduit And Conductors
		Lighting Pull-Box
		Light Distribution Point
		Joint Use Pole
		Pier Cap Underdeck Luminaire
		Pendant Hung Underdeck Luminaire

## SIGNING AND PAVEMENT MARKING SYMBOLS

	Pavement Arrow
	Single Solid Line
	Double Solid Line
	Skip Line
	Stop Bar
	Traffic Sign (Post Mounted)
	Traffic Sign (Overhead)
	Sign Number
	Sign Item Number
	Traffic Flow Arrow

See General Note, Sheet 1 of 3



2010 FDOT Design Standards

### STANDARD SYMBOLS

Last Revision 07/01/05	Sheet No. 3 of 3
Index No. <b>002</b>	

**PRESTRESSED CONCRETE PILE NOTES:**

**DESIGN SPECIFICATIONS:**

Florida Department of Transportation (FDOT) "Structures Design Guidelines", current edition.

American Association of State Highway and Transportation Officials (AASHTO) "LRFD Bridge Design Specifications", current edition.

**DESIGN PARAMETERS:**

Square Prestressed Concrete Section: Designed for 1,000 psi uniform compression after prestress losses without loads.

Pick-up, Storage, and Transportation: 0.0 psi tension using a factor of 1.5 times pile self weight.

**SPIRAL TIES:**

Each wrap of spirals shall be tied to at least two corner strands. One turn required for spiral splices.

**CONCRETE CLASS:**

Concrete for all piles shall be Class V (Special) except designated High Capacity Piles shall be Class VI.

Concrete for the High Capacity Collar Splice shall be Class V (Special).

See "GENERAL NOTES" in Structures Plans for any specific locations where the use of Silica Fume is required.

**CONCRETE STRENGTH:**

The pile cylinder strength shall be 6,000 psi minimum at 28 days and 4,000 psi minimum at time of transfer of the Prestressing Force. The cylinder strength for designated High Capacity Piles shall be 8,500 psi minimum at 28 days and 6,500 psi minimum at time of transfer of the Prestressing Force.

**SPLICE BONDING MATERIAL:**

The material to fill dowelholes and form the joint between pile sections shall be a Type B Epoxy Compound in accordance with Section 926 of the Specifications and shall be contained on the Qualified Products List (QPL). Use Epoxy Bonding Compound or Epoxy Mortar as recommended by the Manufacturer. For Epoxy Mortar only use sand or other filler material supplied by the manufacturer and in the proportions recommended.

**PICK-UP POINTS:**

Piles shall be marked at the pick-up points to indicate proper points for attaching handling lines.

**REINFORCING STEEL:**

All reinforcing steel shall be Grade 60, except that spiral ties shall be manufactured from cold-drawn steel wire meeting the requirements of ASTM A82.

**PRESTRESSING STEEL:**

Prestressing steel shall be seven-wire strand, Grade 270 or 250 as noted.

SR = Stress Relieved Strand  
LRS = Low-Relaxation Strand

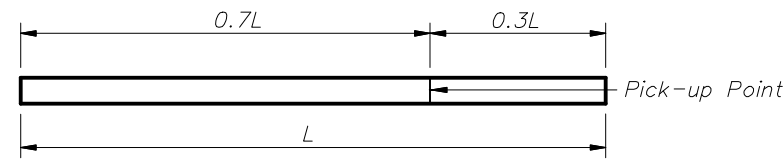

1-POINT PICK-UP

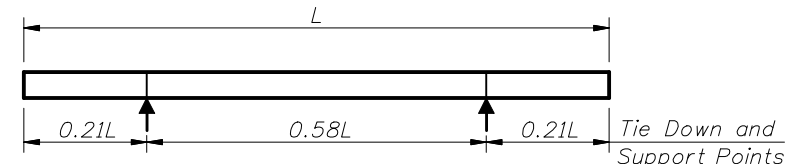

2-POINT SUPPORT

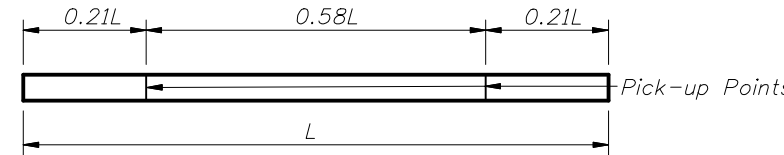

2-POINT PICK-UP

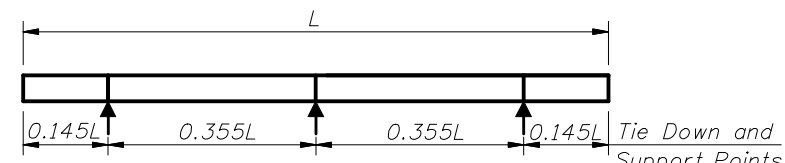

3-POINT SUPPORT

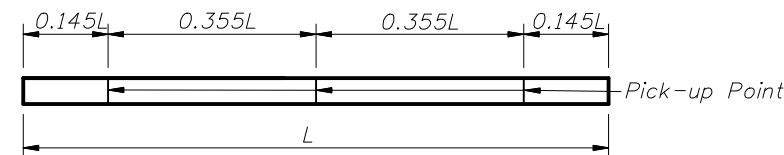

3-POINT PICK-UP  
PILE PICK-UP DETAILS

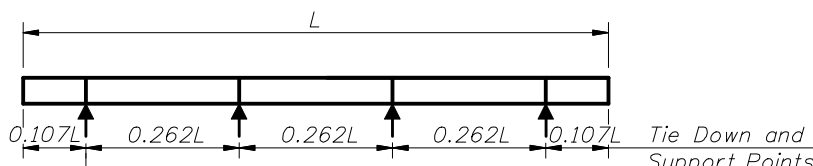

4-POINT SUPPORT

STORAGE AND TRANSPORTATION SUPPORT DETAILS

TABLE OF MAXIMUM PILE PICK-UP AND SUPPORT LENGTHS								
	D = Square Pile Size (inches)						Required Storage and Transportation Detail	Pick-Up Detail
	12	14	18	20	24	30		
Maximum Pile Length (Feet)	48	52	59	62	68	87	2, 3, or 4 point	1 Point
	69	75	85	89	98	124	2, 3, or 4 point	2 Point
	99	107	121	128	140	178	3 or 4 point	3 Point

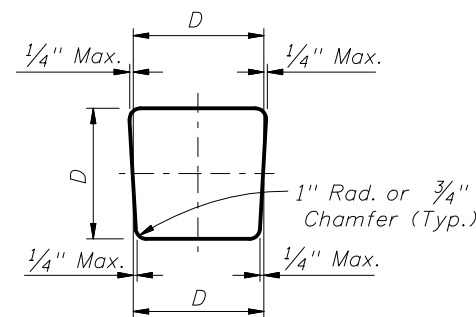

TYPICAL PILE SHAPE FOR MOLD FORMS

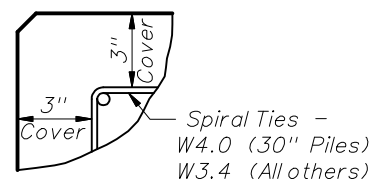

DETAIL SHOWING TYPICAL COVER

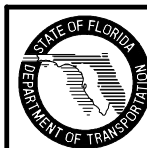

2010 FDOT Design Standards

**NOTES AND DETAILS FOR SQUARE PRESTRESSED CONCRETE PILES**

Last Revision 07/01/07 Sheet No. 1 of 1

Index No. 20600

NOTES:

1. For Sections D-D, E-E, & F-F see Index Nos. 20612, 20614, 20618, 20620, 20624 or 20630 for applicable concrete pile size.
2. Prestressing strands, spiral ties and/or reinforcement are not shown for clarity.
3. In cases where pile splices are desired due to length limitations in shipping and/or handling, the "Drivable Preplanned Prestressed Precast Splice Detail" shall be used. Mechanical Pile Splices contained on the Qualified Products List (QPL) may also be used.
4. When preformed dowelholes are utilized, the 1" spiral tie pitch shall be continued to 4'-0" below the head of the pile, and the preforming material shall be removed. See Index Nos. 20618, 20620 & 20624.

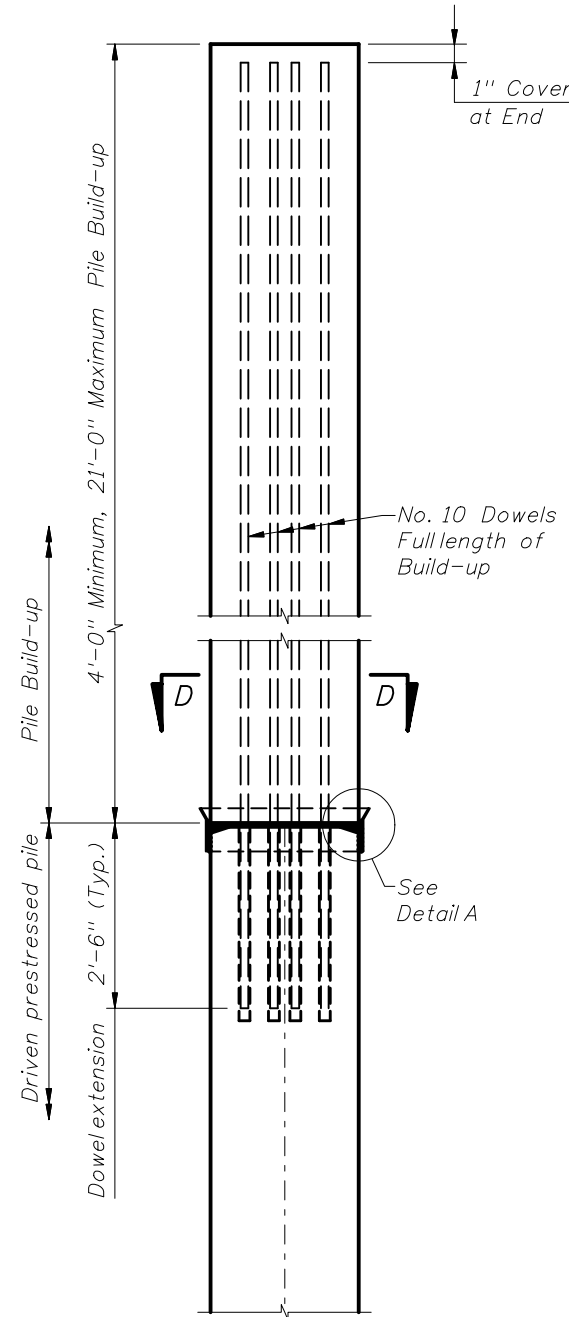
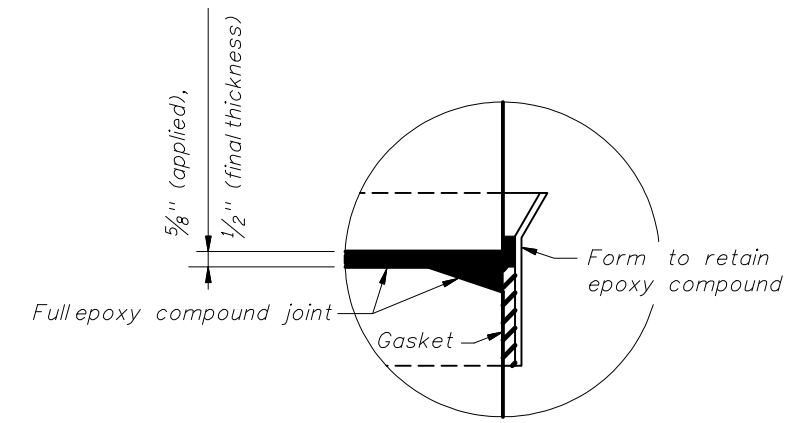

NONDRIVABLE UNFORESEEN  
REINFORCED PRECAST  
PILE BUILD-UP DETAIL

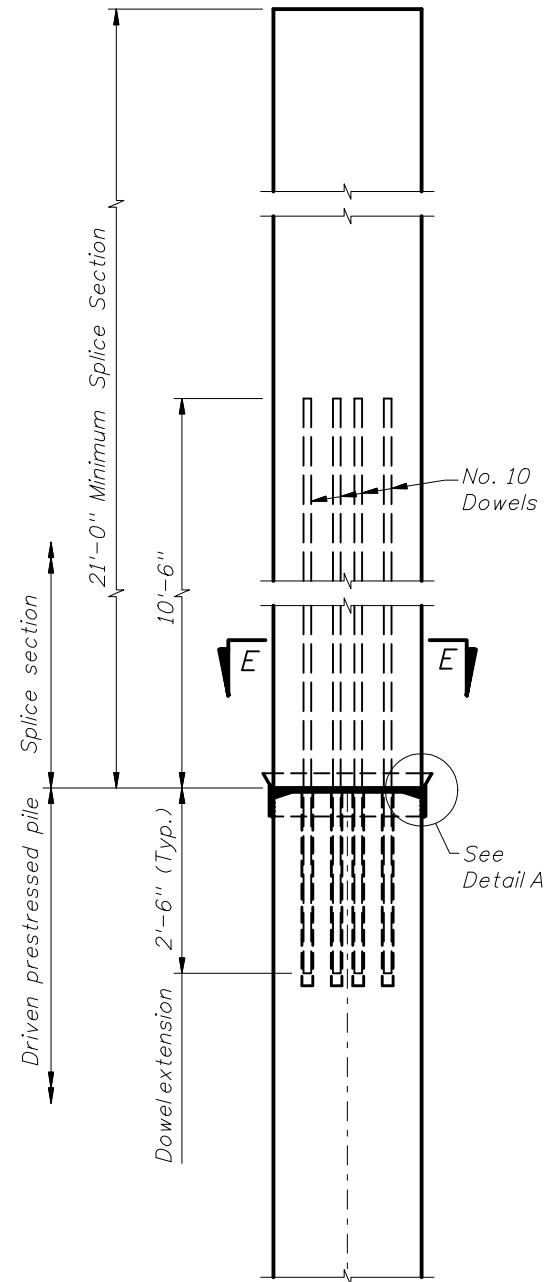

DRIVABLE UNFORESEEN  
PRESTRESSED PRECAST  
PILE SPLICE DETAIL

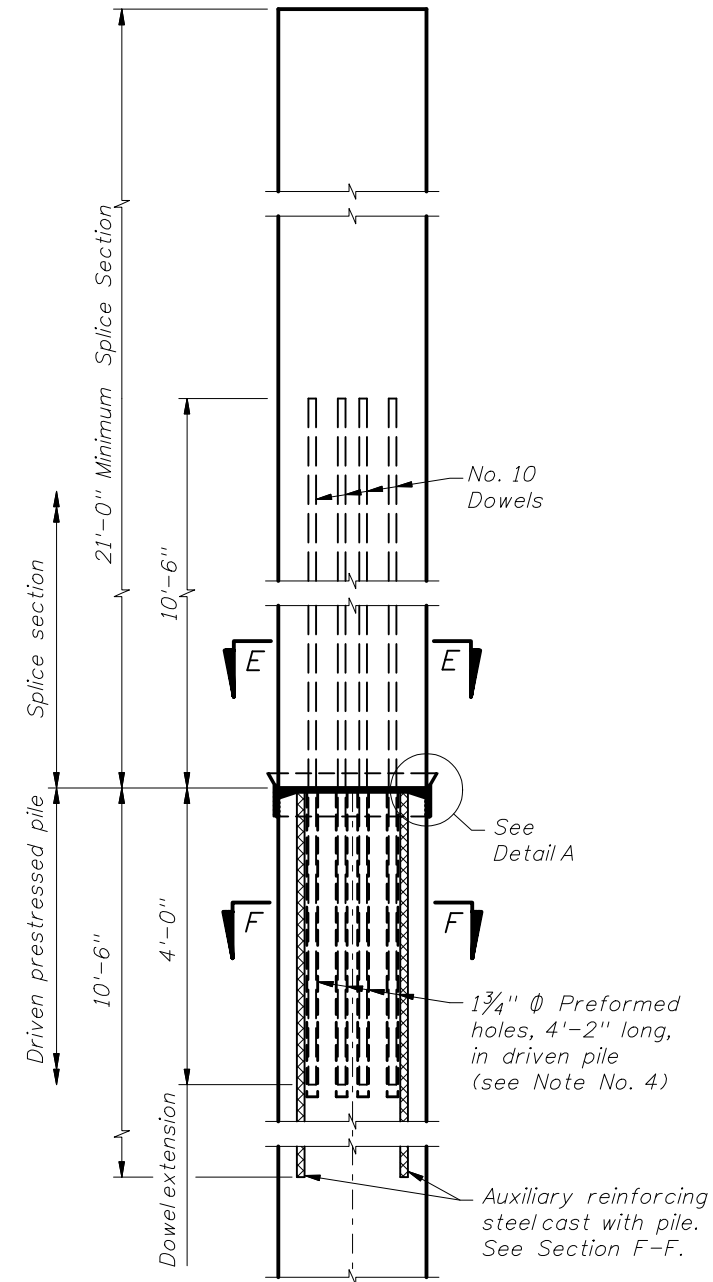

DRIVABLE PREPLANNED  
PRESTRESSED PRECAST  
PILE SPLICE DETAIL

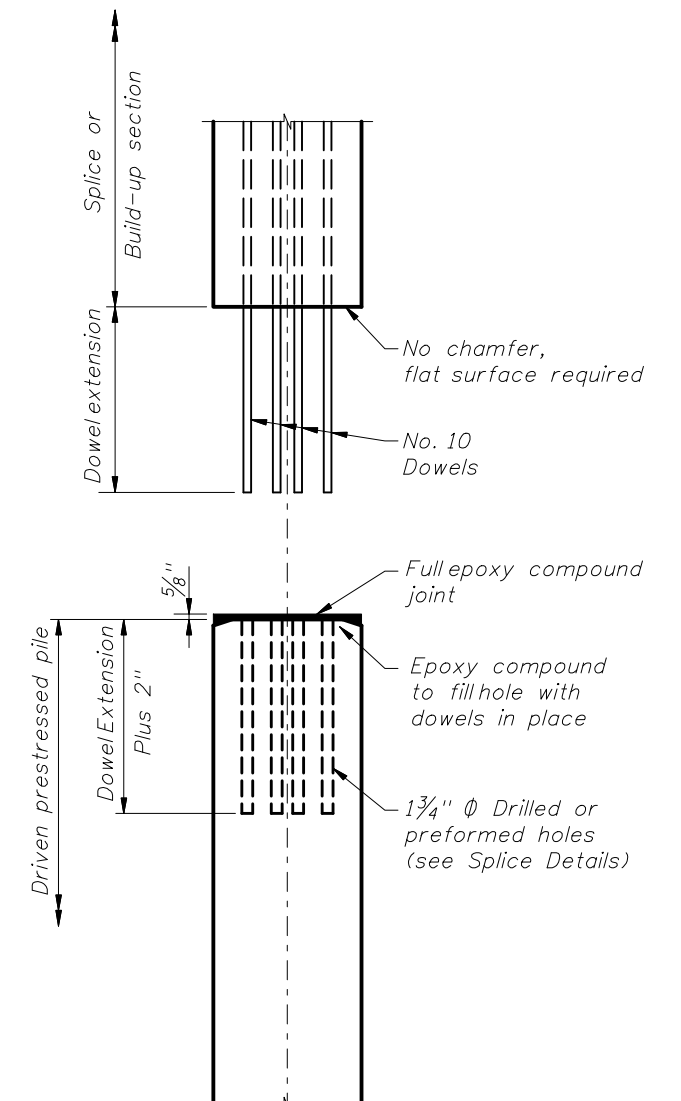

TYPICAL SPLICE  
BEFORE BONDING



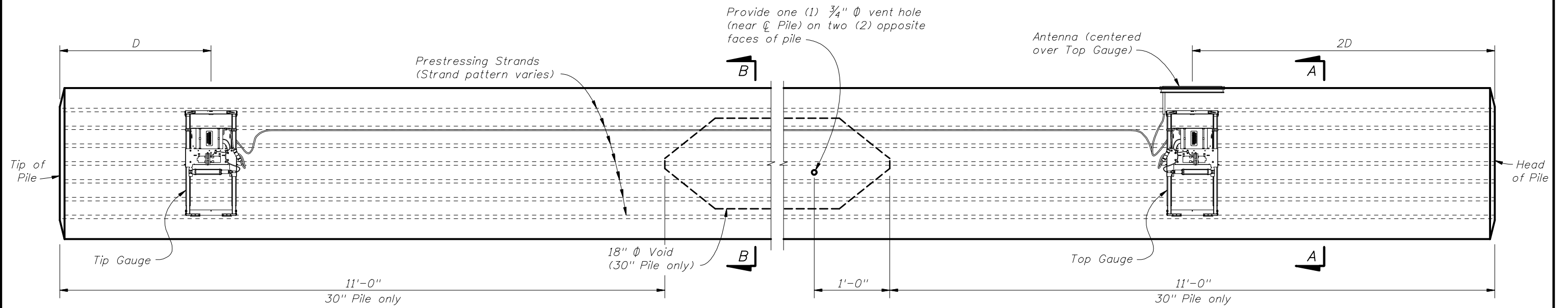

ELEVATION

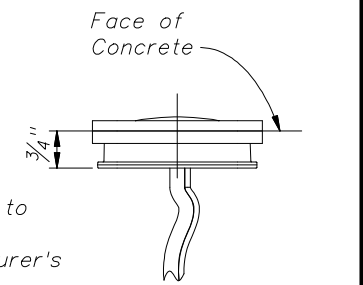
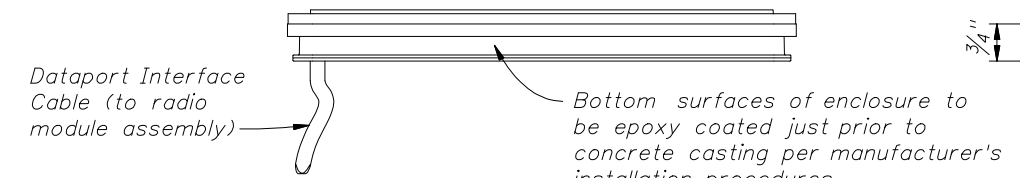
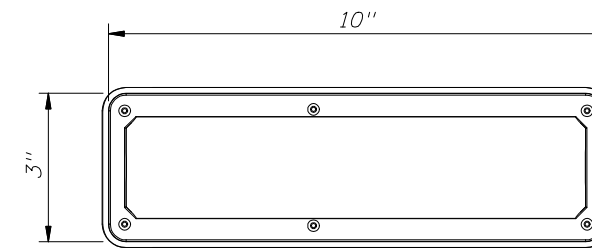
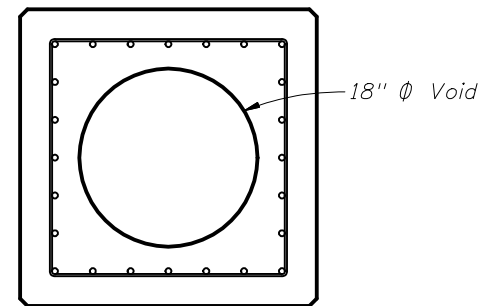
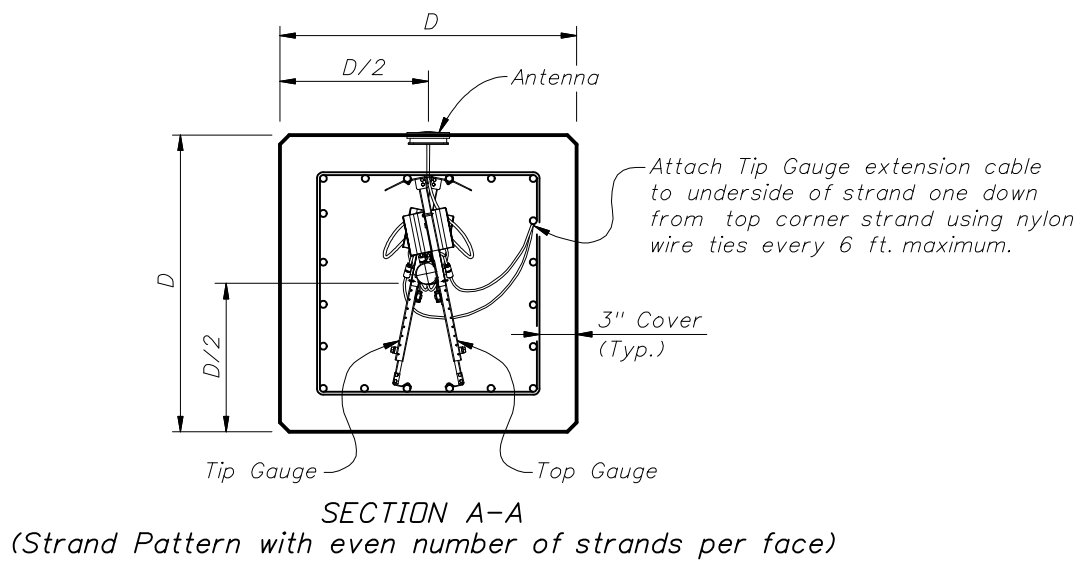
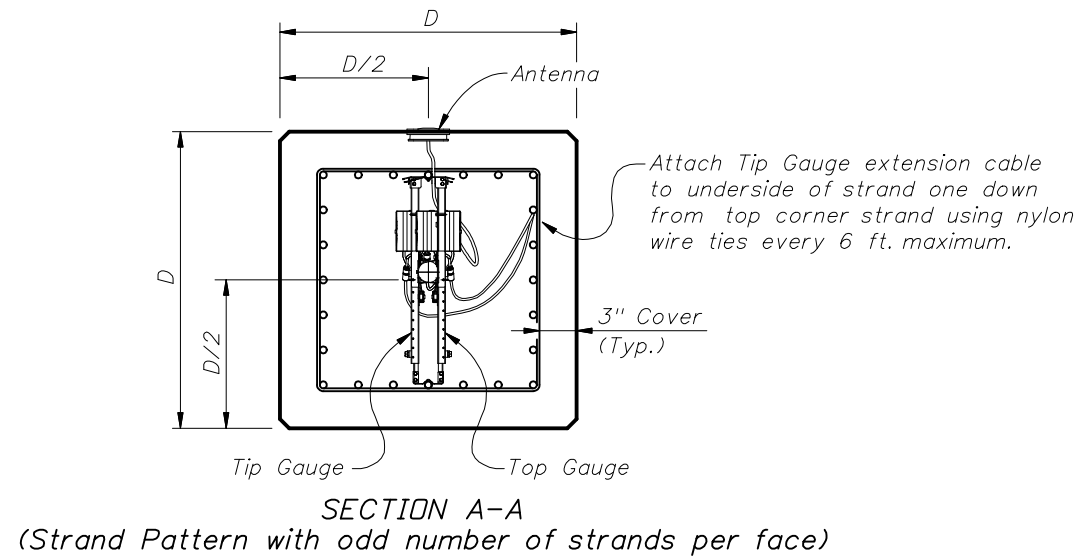

Work this sheet with  
 Index No. 20618 for 18" square piles,  
 Index No. 20624 for 24" square piles,  
 Index No. 20630 for 30" square piles.



2010 FDOT Design Standards

EDC INSTRUMENTATION FOR  
 SQUARE PRESTRESSED CONCRETE PILES

Last Revision 01/01/08 Sheet No. 1 of 1

Index No. 20602

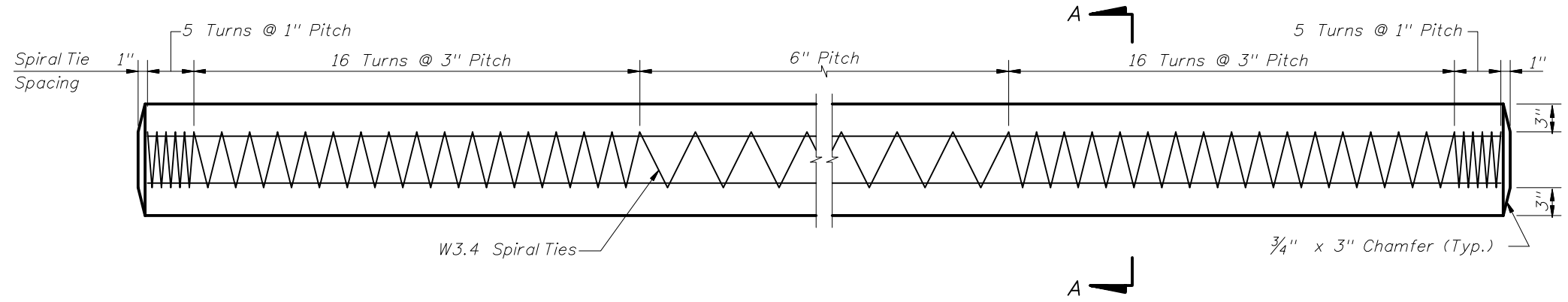

ELEVATION

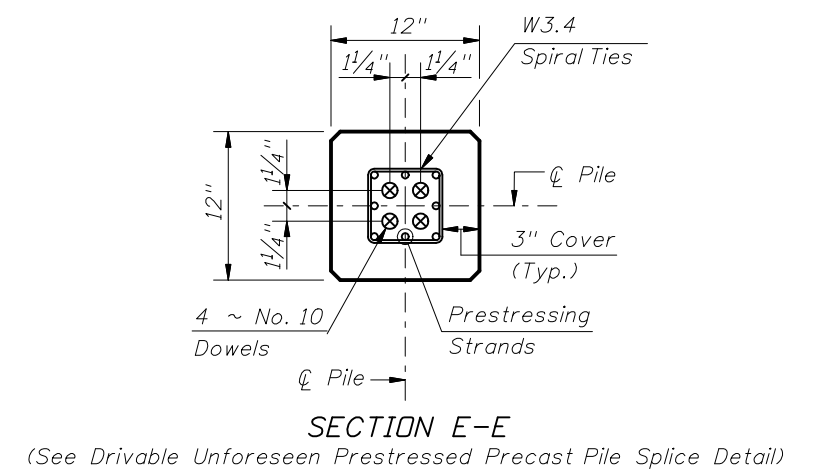
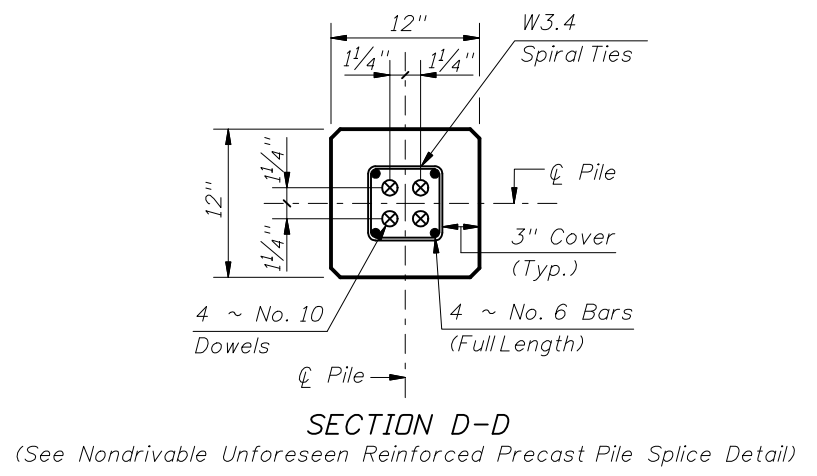

PILE SPLICE REINFORCEMENT DETAILS

ALTERNATE STRAND PATTERNS

- 4 ~ 0.6"  $\Phi$ , Grade 270 LRS, at 44 kips
- 8 ~ 7/16"  $\Phi$ , Grade 270 LRS, at 23.3 kips
- 8 ~ 1/2"  $\Phi$ , Grade 250 SR, at 24.1 kips
- 12 ~ 3/8"  $\Phi$ , Grade 270 LRS, at 17.2 kips
- 12 ~ 7/8"  $\Phi$ , Grade 270 SR, at 15.6 kips

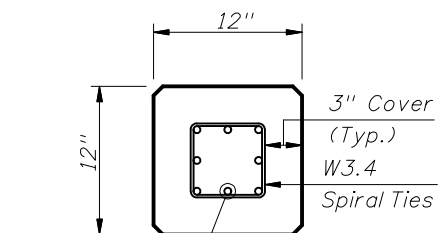

See Alternate Strand Patterns  
SECTION A-A

NOTE:  
Any of the given Alternate Strand Patterns may be utilized. The strands shall be located as follows:  
Place one strand at each corner and place the remaining strands equally spaced between the corner strands.  
The total strand pattern shall be concentric with the nominal concrete section of the pile.

NOTE:  
Work this Index with Index No. 20600 - Notes and Details for Square Prestressed Concrete Piles and Index No. 20601 - Square Prestressed Concrete Pile Splices.



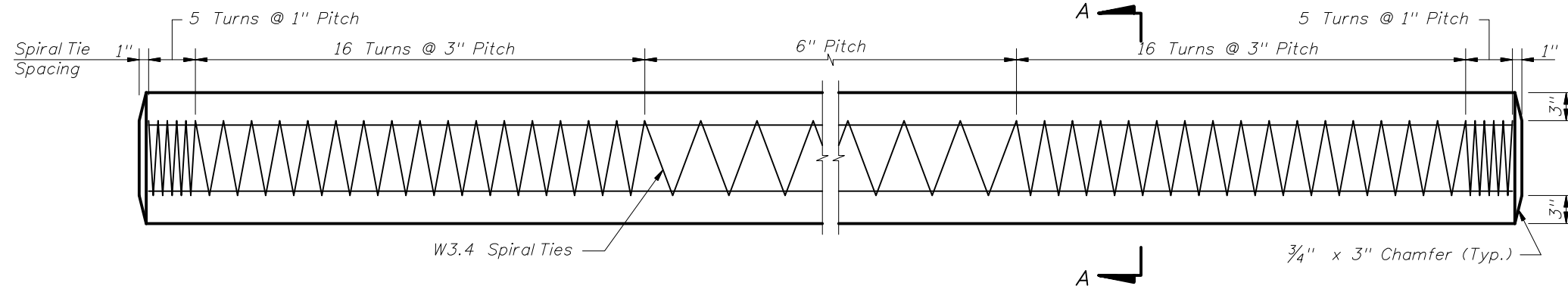

ELEVATION

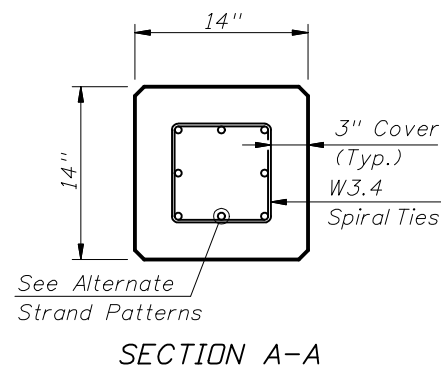

ALTERNATE STRAND PATTERNS

- 8 ~ 0.6"  $\Phi$ , Grade 270 LRS, at 35.2 kips
- 8 ~ 1/2"  $\Phi$ , Grade 270 (Spec) LRS, at 31.6 kips
- 8 ~ 1/2"  $\Phi$ , Grade 270 (Spec) SR, at 31.6 kips
- 8 ~ 1/2"  $\Phi$ , Grade 270 LRS, at 31.0 kips
- 12 ~ 7/16"  $\Phi$ , Grade 270 SR, at 21.2 kips
- 12 ~ 1/2"  $\Phi$ , Grade 250 SR, at 22.6 kips
- 16 ~ 3/8"  $\Phi$ , Grade 270 SR, at 16.1 kips

NOTE:

Any of the given Alternate Strand Patterns may be utilized. The strands shall be located as follows:  
Place one strand at each corner and place the remaining strands equally spaced between the corner strands.  
The total strand pattern shall be concentric with the nominal concrete section of the pile.

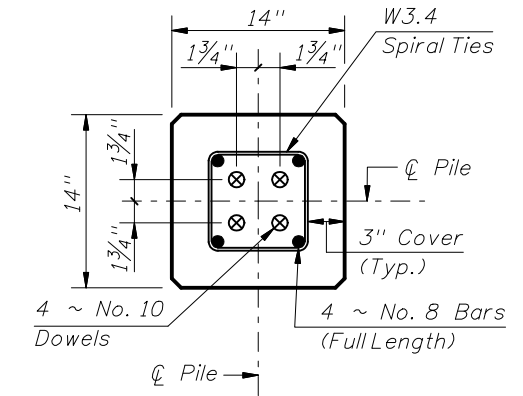

SECTION D-D  
(See Non-drivable Unforeseen Reinforced Precast Splice Detail)

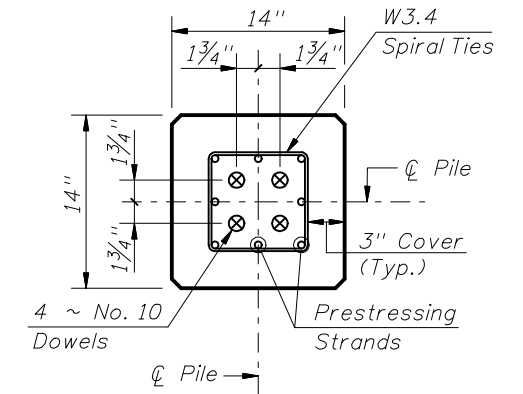

SECTION E-E  
(See Drivable Unforeseen Prestressed Precast Splice Detail)

PILE SPLICE REINFORCEMENT DETAILS

NOTE:

Work this Index with Index No. 20600 - Notes and Details for Square Prestressed Concrete Piles and Index No. 20601 - Square Prestressed Concrete Pile Splices.



2010 FDOT Design Standards

14" SQUARE PRESTRESSED CONCRETE PILE

Last Revision	Sheet No.
07/01/05	1 of 1
Index No.	
20614	

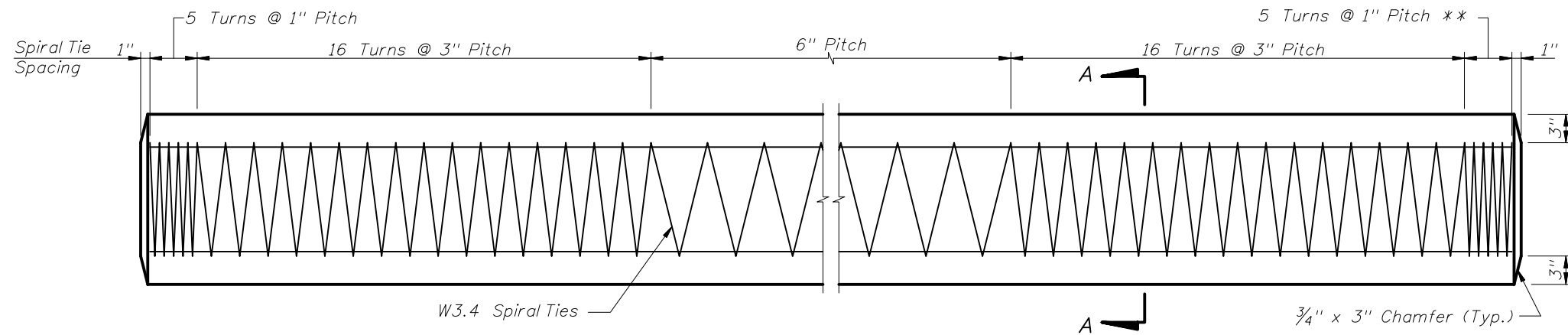

ELEVATION

\*\* See Note No. 4 on Index No. 20601

**ALTERNATE STRAND PATTERNS**

- 12 ~ 0.6"  $\Phi$ , Grade 270 LRS, at 38.1 kips
- 12 ~ 1/2"  $\Phi$ , Grade 270 (Spec) LRS, at 34.0 kips
- 12 ~ 9/16"  $\Phi$ , Grade 270 SR, at 35.1 kips
- 16 ~ 1/2"  $\Phi$ , Grade 270 SR, at 26.8 kips
- 20 ~ 7/16"  $\Phi$ , Grade 270 SR, at 21.8 kips
- 20 ~ 7/16"  $\Phi$ , Grade 270 LRS, at 21.1 kips
- 24 ~ 3/8"  $\Phi$ , Grade 270 LRS, at 17.3 kips

NOTE:  
Any of the given Alternate Strand Patterns may be utilized.  
The strands shall be located as follows:  
Place one strand at each corner and place the remaining strands equally spaced between the corner strands.  
The total strand pattern shall be concentric with the nominal concrete section of the pile.

NOTE:  
Work this Index with Index No. 20600 - Notes and Details for Square Prestressed Concrete Piles and Index No. 20601 - Square Prestressed Concrete Pile Splices.

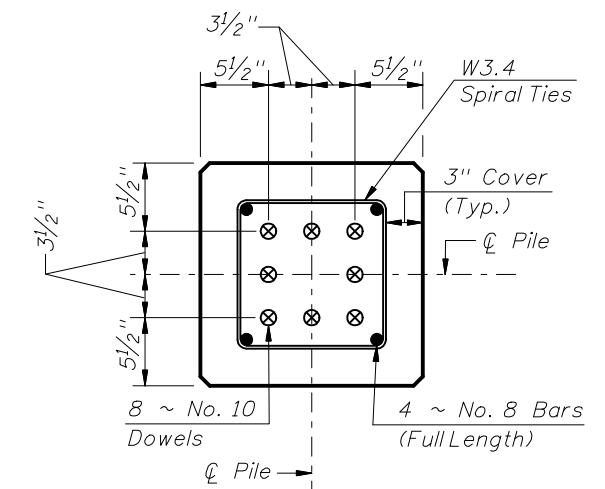
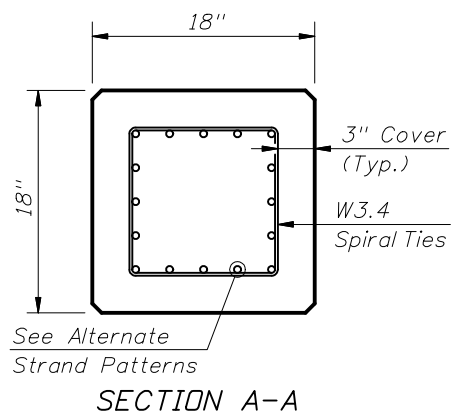

SECTION D-D  
(See Non-drivable Unforeseen Reinforced Precast Splice Detail)

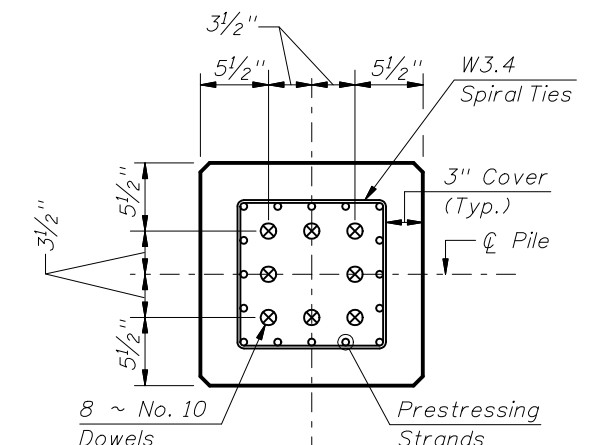

SECTION E-E  
(See Drivable Prestressed Precast Splice Detail)

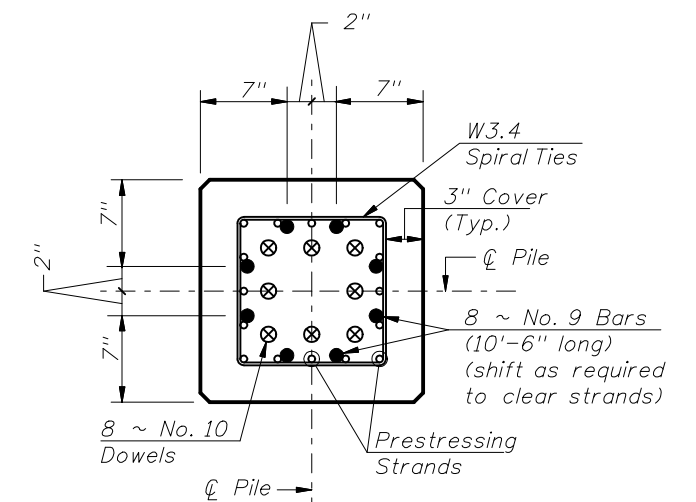

SECTION F-F  
(See Drivable Preplanned Splice Detail)

**PILE SPLICE REINFORCEMENT DETAILS**

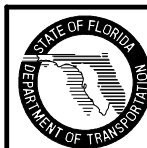

2010 FDOT Design Standards

**18" SQUARE PRESTRESSED CONCRETE PILE**

Last Revision 07/01/05 Sheet No. 1 of 1

Index No. 20618



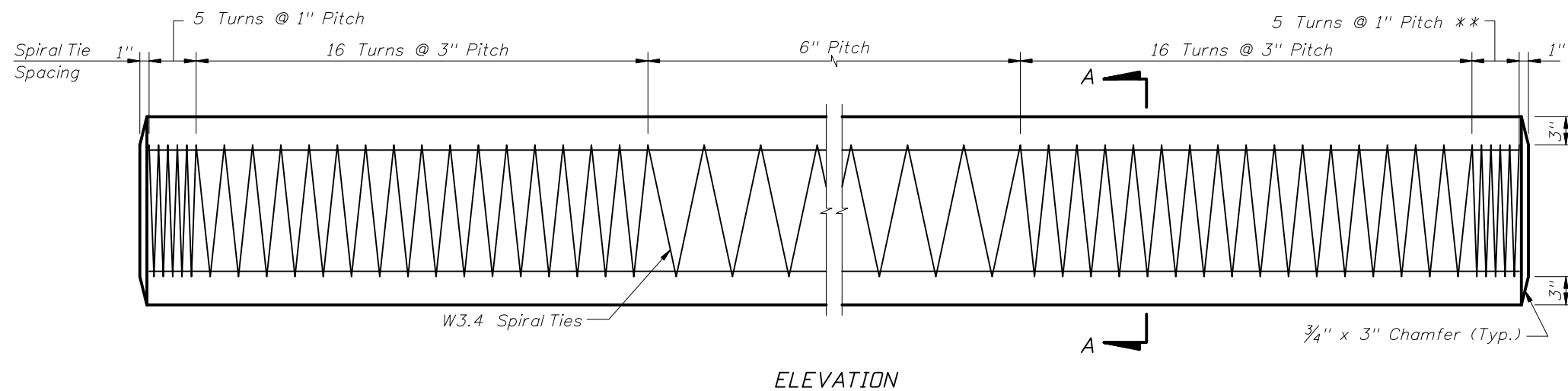

\*\* See Note No. 4 on Index No. 20601

**ALTERNATE STRAND PATTERNS**

- 12 ~ 0.6"  $\Phi$ , Grade 270 LRS, at 44 kips
- 16 ~ 1/2"  $\Phi$ , Grade 270 LRS, at 31.0 kips
- 16 ~ 1/2"  $\Phi$ , Grade 270 (Spec) SR, at 34.0 kips
- 20 ~ 1/2"  $\Phi$ , Grade 270 SR, at 26.5 kips
- 24 ~ 7/16"  $\Phi$ , Grade 270 LRS, at 21.7 kips
- 24 ~ 7/16"  $\Phi$ , Grade 270 SR, at 21.7 kips

**NOTE:**  
 Any of the given Alternate Strand Patterns may be utilized. The strands shall be located as follows:  
 Place one strand at each corner and place the remaining strands equally spaced between the corner strands.  
 The total strand pattern shall be concentric with the nominal concrete section of the pile.

**NOTE:**  
 Work this Index with Index No. 20600 - Notes and Details for Square Prestressed Concrete Piles and Index No. 20601 - Square Prestressed Concrete Pile Splices.

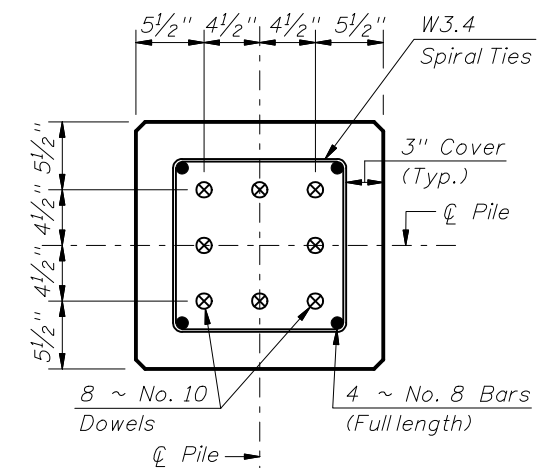
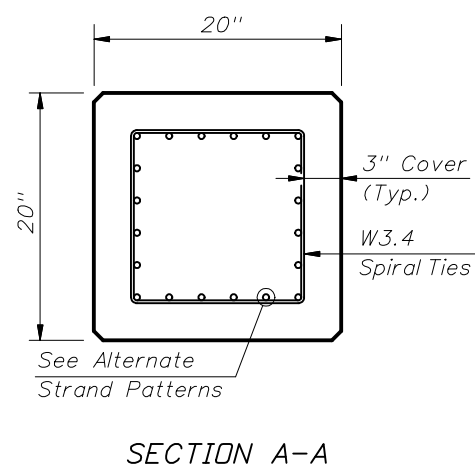

(See Nondrivable Unforeseen Reinforced Precast Pile Splice Detail)

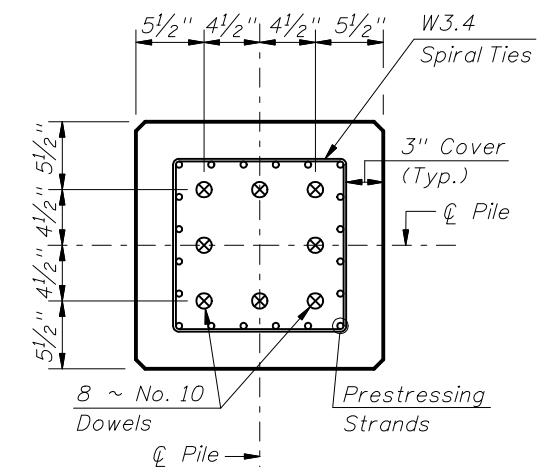

(See Drivable Prestressed Precast Pile Splice Detail)

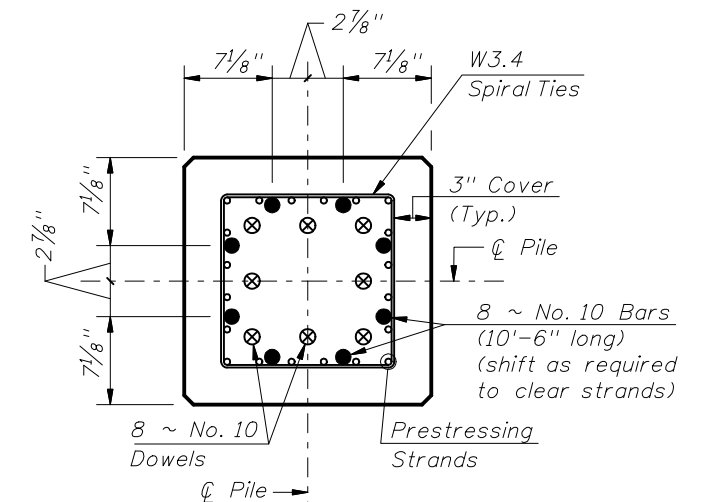

(See Drivable Preplanned Pile Splice Detail)

**PILE SPLICE REINFORCEMENT DETAILS**



2010 FDOT Design Standards

**20" SQUARE PRESTRESSED CONCRETE PILE**

Last Revision 07/01/05 Sheet No. 1 of 1

Index No. 20620

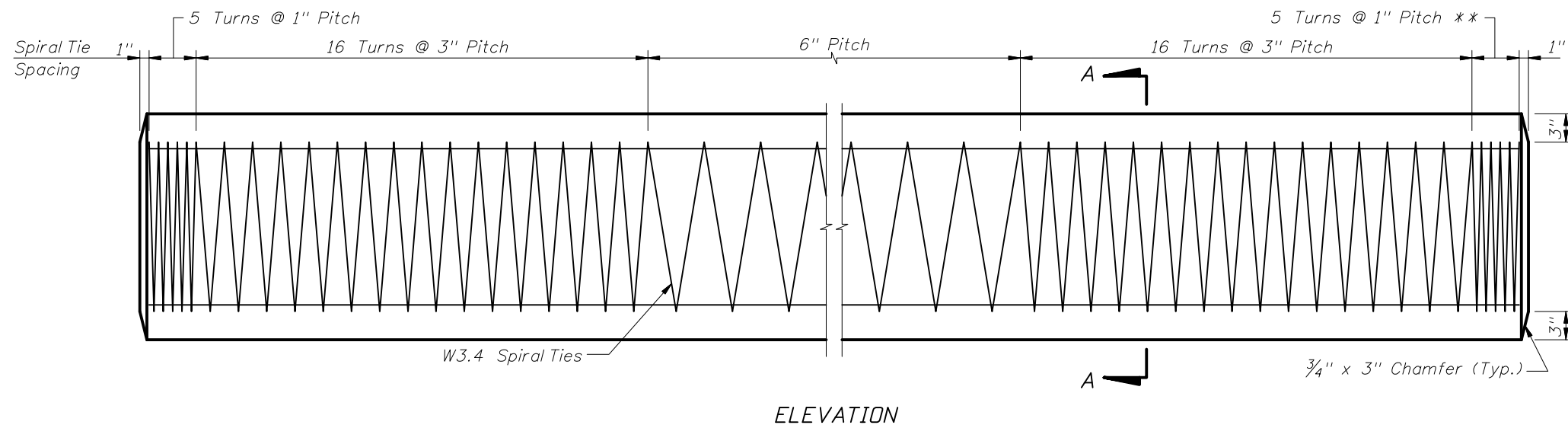

\*\* See Note No. 4 on Index No. 20601

**ALTERNATE STRAND PATTERNS**

- 16 ~ 0.6"  $\Phi$ , Grade 270 LRS, at 44 kips
- 20 ~ 1/2"  $\Phi$ , Grade 270 (Spec) LRS, at 34.0 kips
- 20 ~ 9/16"  $\Phi$ , Grade 270 SR, at 39.0 kips
- 20 ~ 9/16"  $\Phi$ , Grade 270 (Spec) SR, at 37.1 kips
- 24 ~ 1/2"  $\Phi$ , Grade 270 LRS, at 31.0 kips
- 24 ~ 1/2"  $\Phi$ , Grade 270 (Spec) SR, at 31.6 kips

NOTE:  
Any of the given Alternate Strand Patterns may be utilized.  
The strands shall be located as follows:  
Place one strand at each corner and place the remaining strands equally spaced between the corner strands.  
The total strand pattern shall be concentric with the nominal concrete section of the pile.

NOTE:  
Work this Index with Index No. 20600 - Notes and Details for Square Prestressed Concrete Piles and Index No. 20601 - Square Prestressed Concrete Pile Splices.

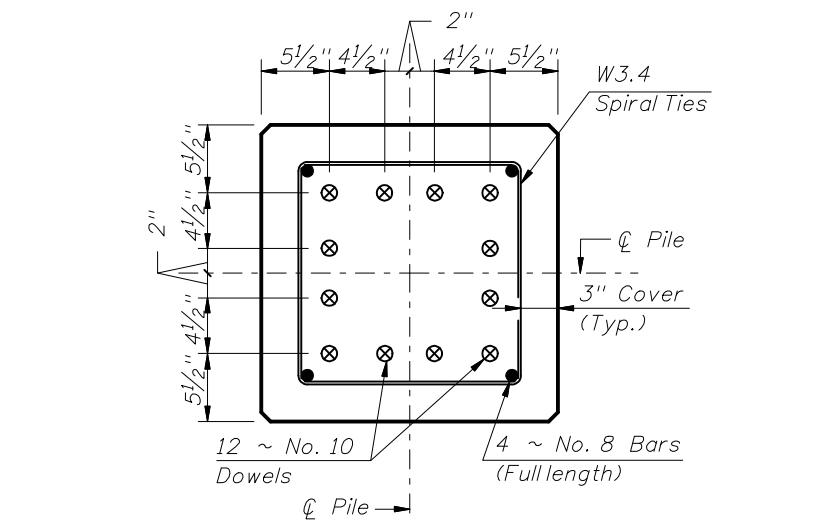
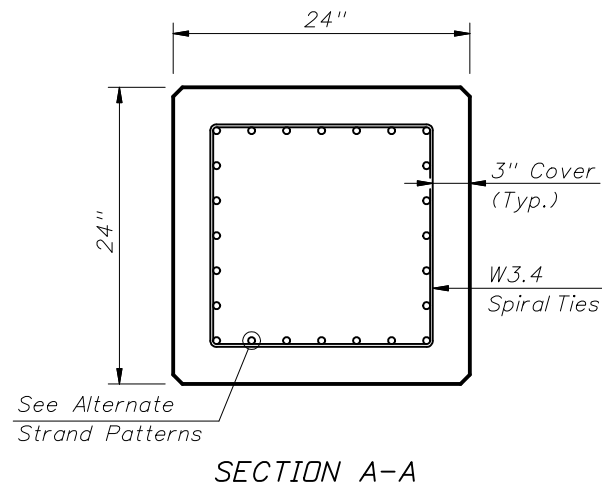

(See Nondrivable Unforeseen Reinforced Precast Pile Splice Detail)

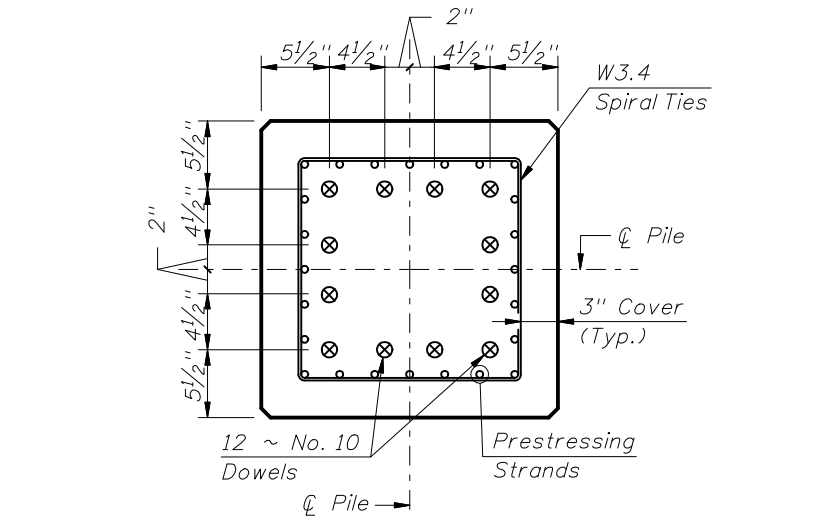

(See Drivable Prestressed Precast Pile Splice Detail)

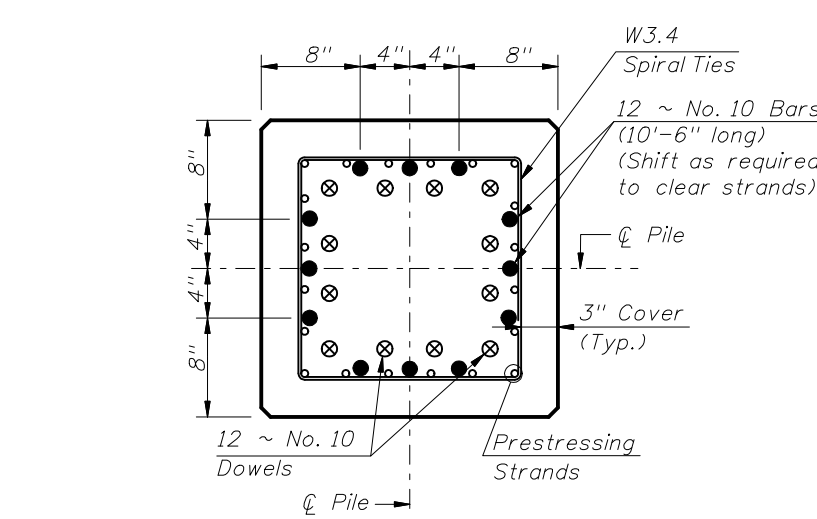

(See Drivable Preplanned Pile Splice Detail)



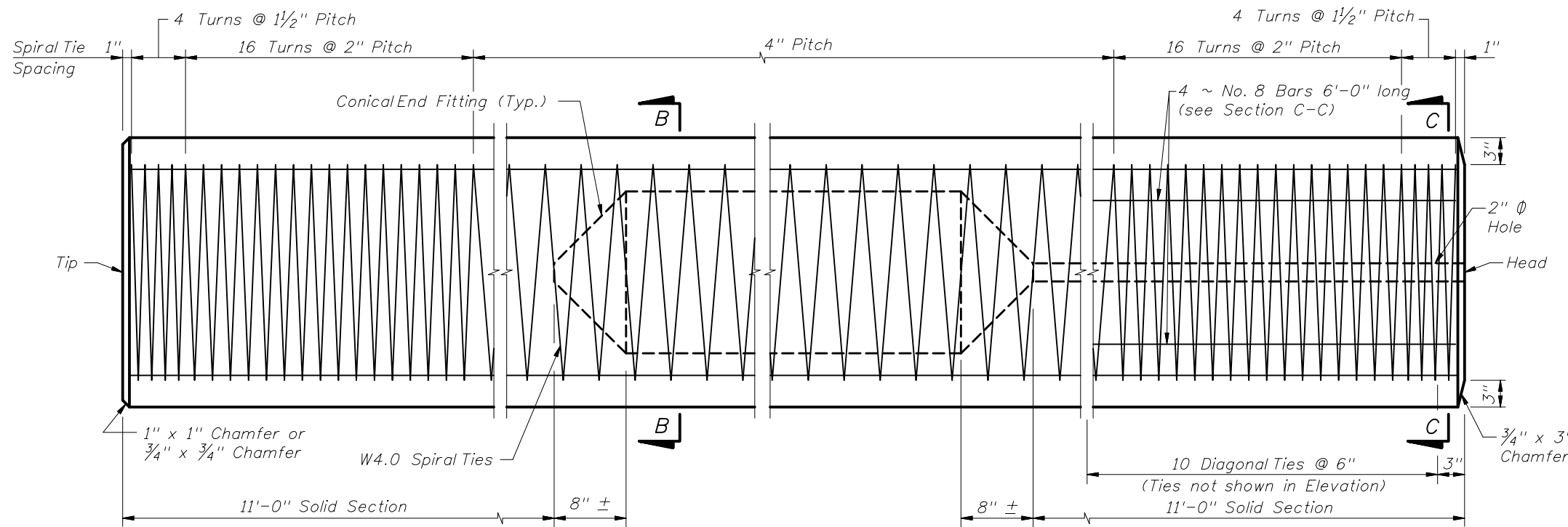

NOTE:  
Work this Index with Index No. 20600 - Notes and Details for Square Prestressed Concrete Piles and Index No. 20601 - Square Prestressed Concrete Pile Splices.

ELEVATION

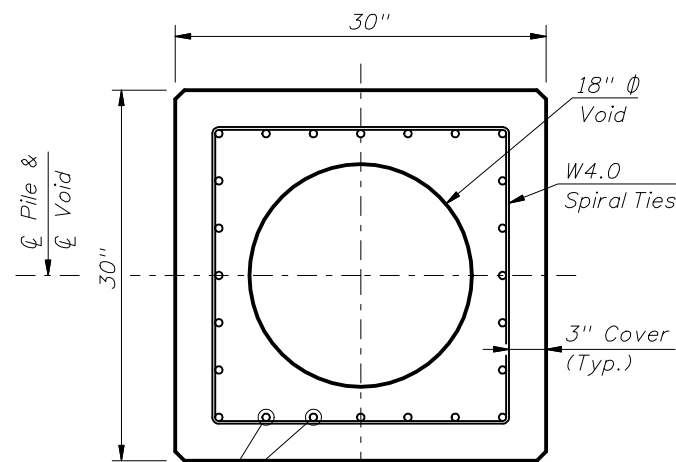

SECTION B-B  
(See Pile Splice Reinforcement Details)

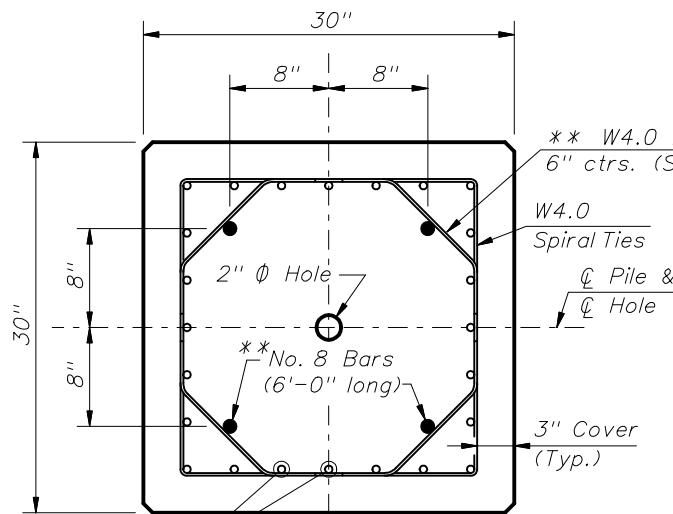

SECTION C-C  
(See Pile Splice Reinforcement Details)

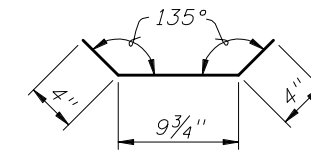

W4.0 DIAGONAL TIE DETAIL

\*\* Omit 4 ~ No. 8 Bars and Diagonal Ties in pre-planned mechanical splice.

NOTES:

- Venting shall be provided by the use of a 1"  $\Phi$  PVC conduit through a substructure cap or column. Voids between segments of spliced piles shall be connected by 2"  $\Phi$  hole(s).
- Any of the given Alternate Strand Patterns may be utilized. The strands shall be located as follows: Place one strand at each corner and place the remaining strands equally spaced between the corner strands. The total strand pattern shall be concentric with the nominal concrete section of the pile.
- CONTRACTOR OPTION: The 30" pile may be cast SOLID by omitting the 18"  $\Phi$  void and the 2"  $\Phi$  vent hole. In this event, the Contractor shall submit calculations for approval and a proposed strand configuration that provide net prestressing after losses equal to 1000 psi. Alternate configurations for the Diagonal Ties, to maintain the position of the 4 ~ No. 8 Bars, may be approved by the Engineer.

ALTERNATE STRAND PATTERNS

- 20 ~ 3/16"  $\Phi$ , Grade 270 (Spec) LRS, at 39.7 kips
- 20 ~ 3/16"  $\Phi$ , Grade 270 LRS, at 39.0 kips
- 20 ~ 0.6"  $\Phi$ , Grade 270 LRS, at 41 kips
- 24 ~ 1/2"  $\Phi$ , Grade 270 (Spec) LRS, at 34.0 kips
- 24 ~ 3/16"  $\Phi$ , Grade 270 SR, at 35 kips
- 24 ~ 3/16"  $\Phi$ , Grade 270 (Spec) SR, at 35.2 kips
- 28 ~ 1/2"  $\Phi$ , Grade 270 LRS, at 29.0 kips
- 28 ~ 1/2"  $\Phi$ , Grade 270 (Spec) SR, at 30.2 kips

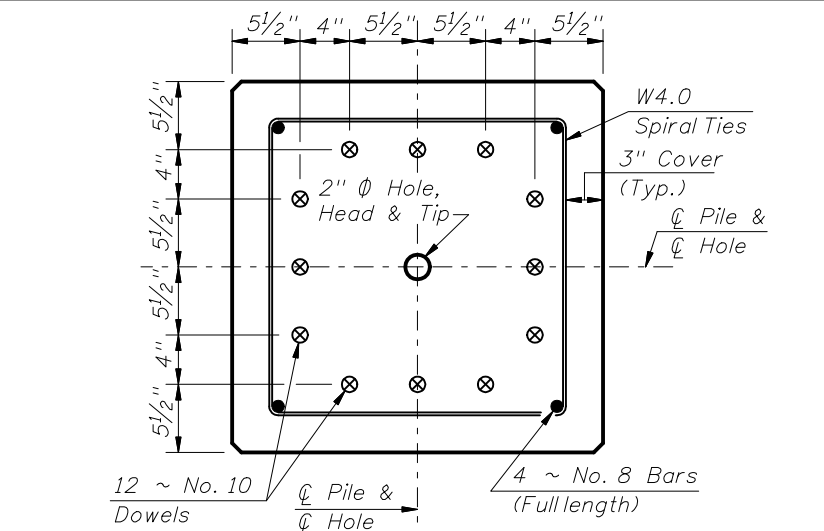

SECTION D-D  
(See Nondrivable Unforeseen Reinforced Precast Pile Splice Detail)

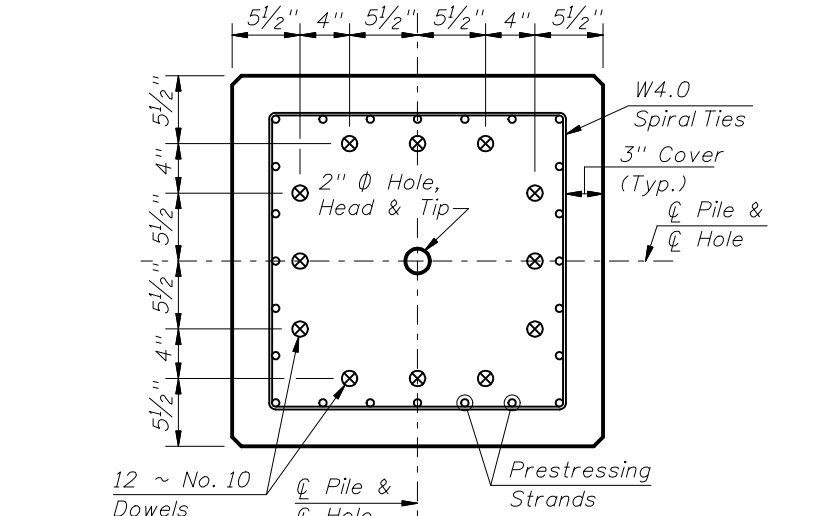

SECTION E-E  
(See Drivable Prestressed Precast Pile Splice Detail)

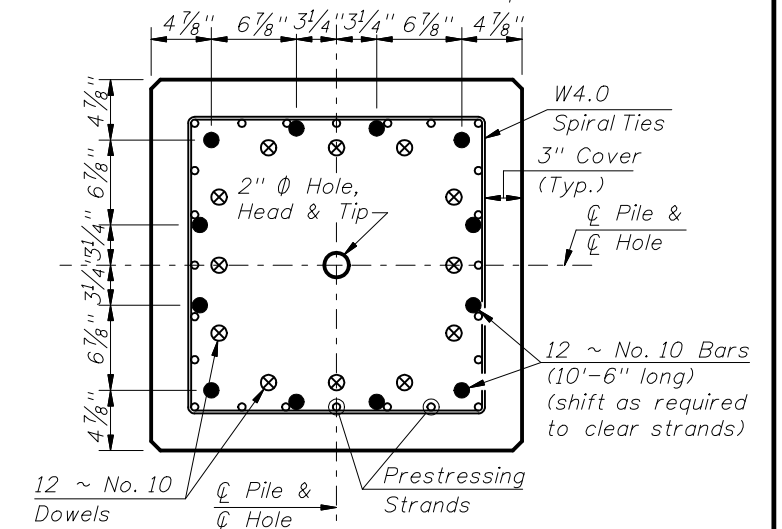

SECTION F-F  
(See Drivable Preplanned Pile Splice Detail)

PILE SPLICE DETAILS

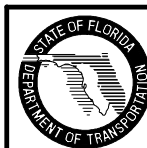

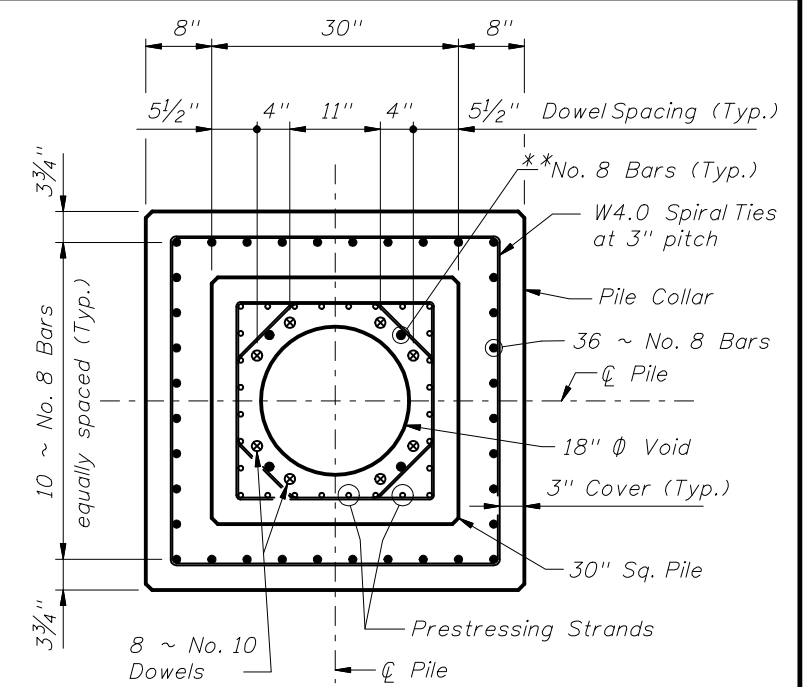
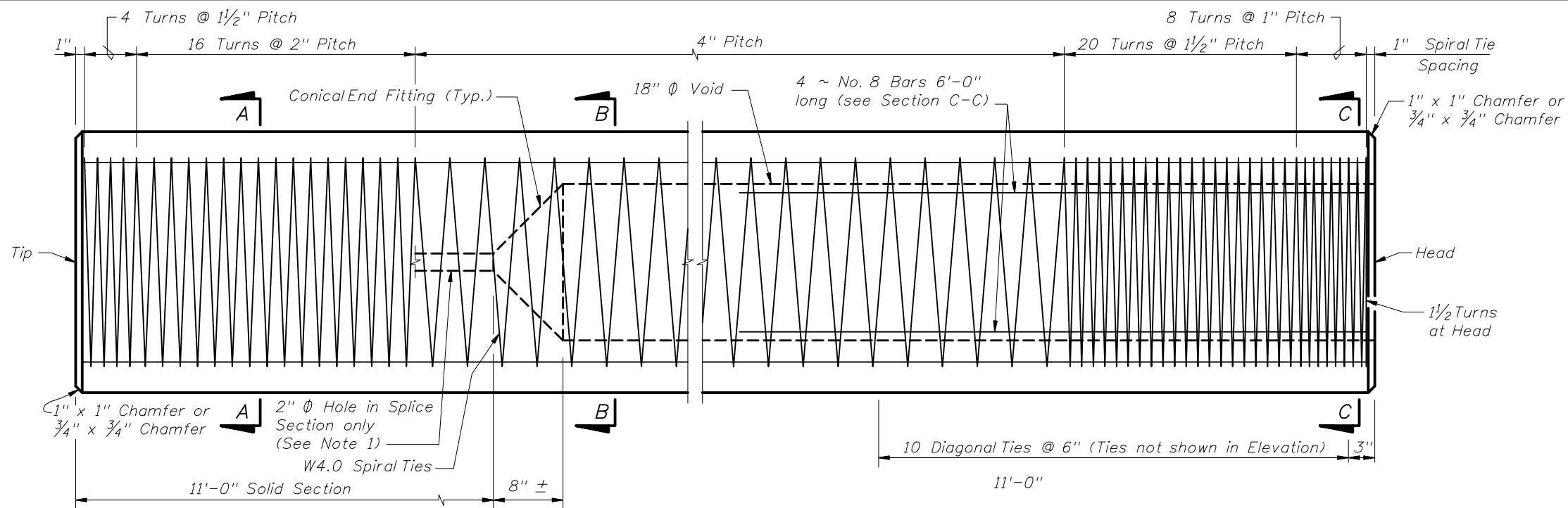

SECTION D-D  
SECTION THRU PILE COLLAR

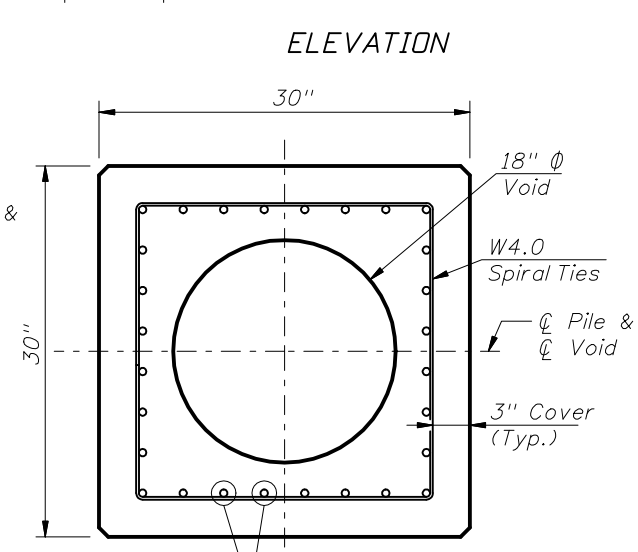
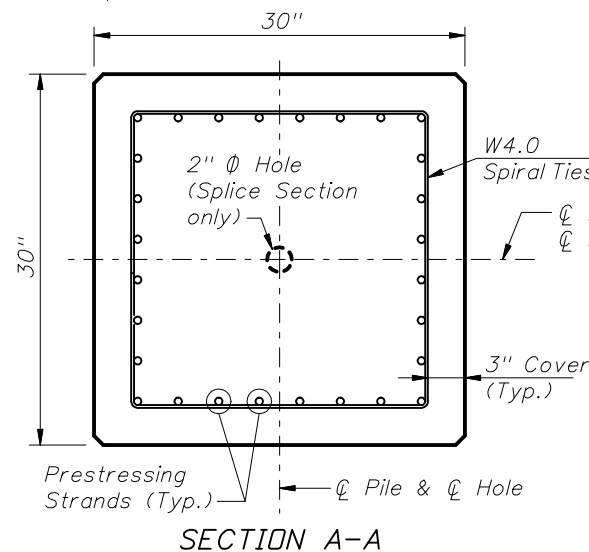

ELEVATION

SECTION B-B

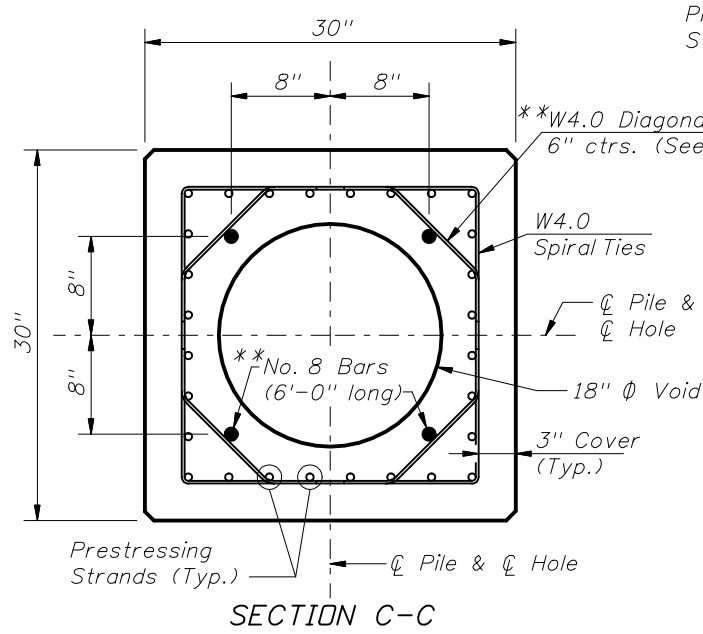

SECTION C-C

STRAND PATTERN

28 ~ 0.6" Ø, Grade 270 LRS, at 29.5 kips

NOTES:

- Venting shall be provided by the use of a 1" Ø PVC conduit through a substructure cap or column. Voids between segments of spliced piles shall be connected by 2" Ø hole(s).
- After the pile is driven and cut to grade, the top 8'-0" of the 18" Ø Void shall be filled with concrete. Prior to filling the top 8'-0" of the 18" Ø Void with concrete, strip the cardboard form material from the void. A stay-in-place corrugated thin wall galvanized pipe may be used to form the void in lieu of the cardboard form material. The concrete fill material shall be of the same type and strength as called for in the pile cap and paid for as substructure concrete.
- Collar concrete shall reach a strength of 6,000 psi before pile driving is resumed.
- Work this Index with Index No. 20600 - Notes and Details for Square Prestressed Concrete Piles.

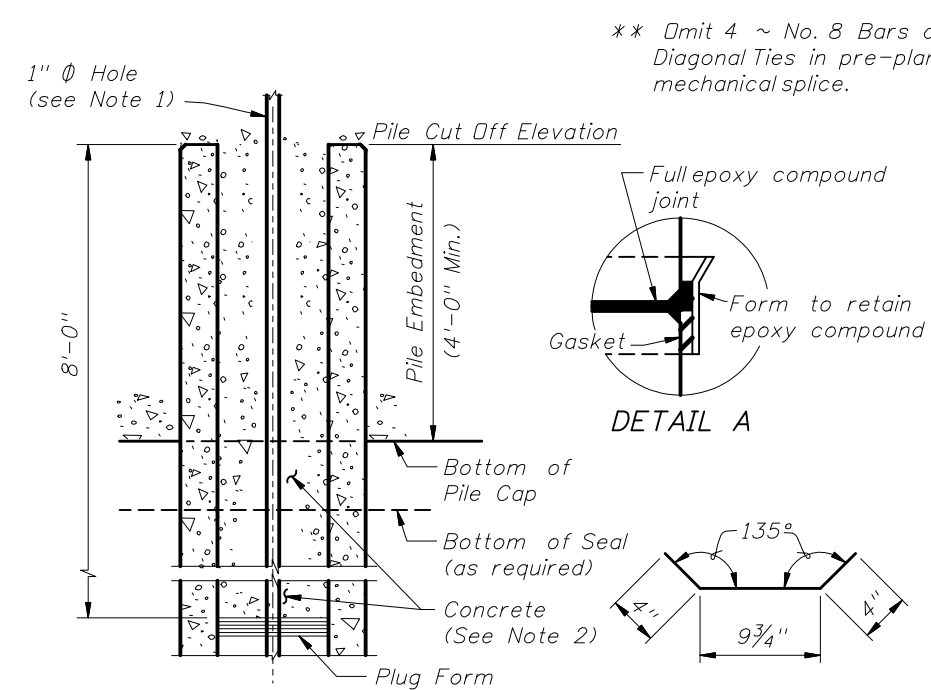

SECTION THROUGH PILE AT PILE CAP  
W4.0 DIAGONAL TIE DETAIL

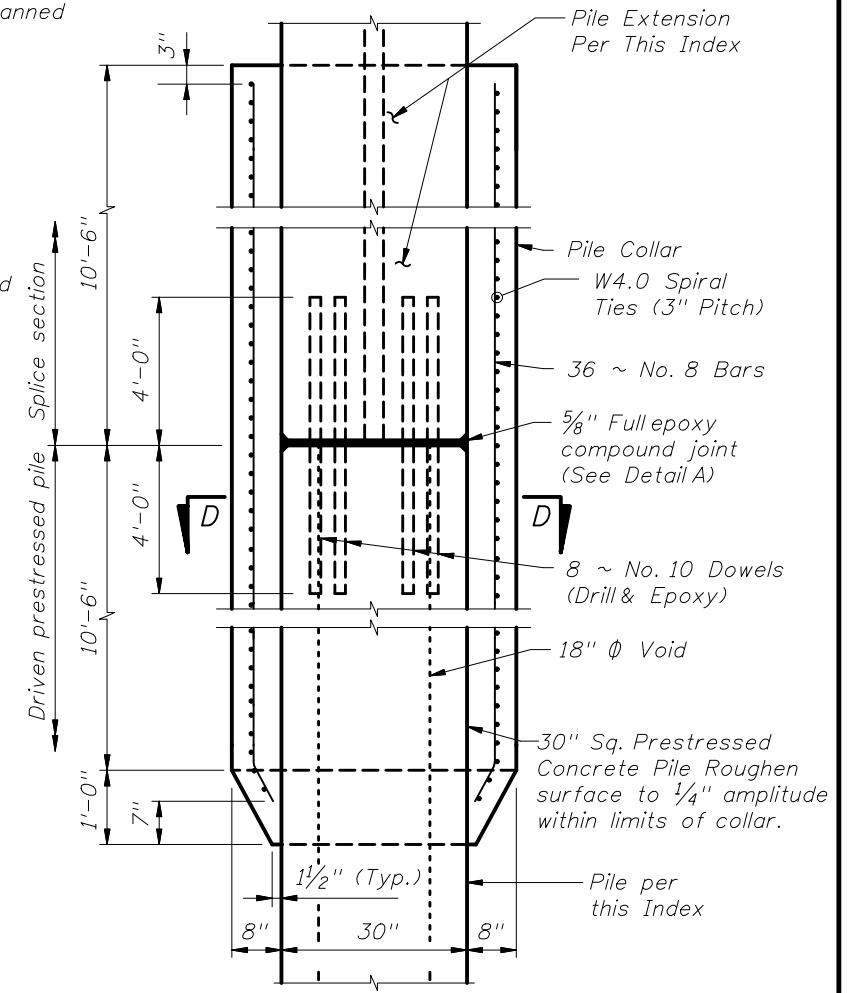

DETAIL OF PILE COLLAR FOR HIGH CAPACITY 30" SQUARE PRESTRESSED PILE  
-PILE SPLICE DETAIL-



2010 FDOT Design Standards

HIGH MOMENT CAPACITY 30" SQUARE PRESTRESSED CONCRETE PILE

Last Revision	Sheet No.
07/01/07	1 of 1
Index No.	
20631	

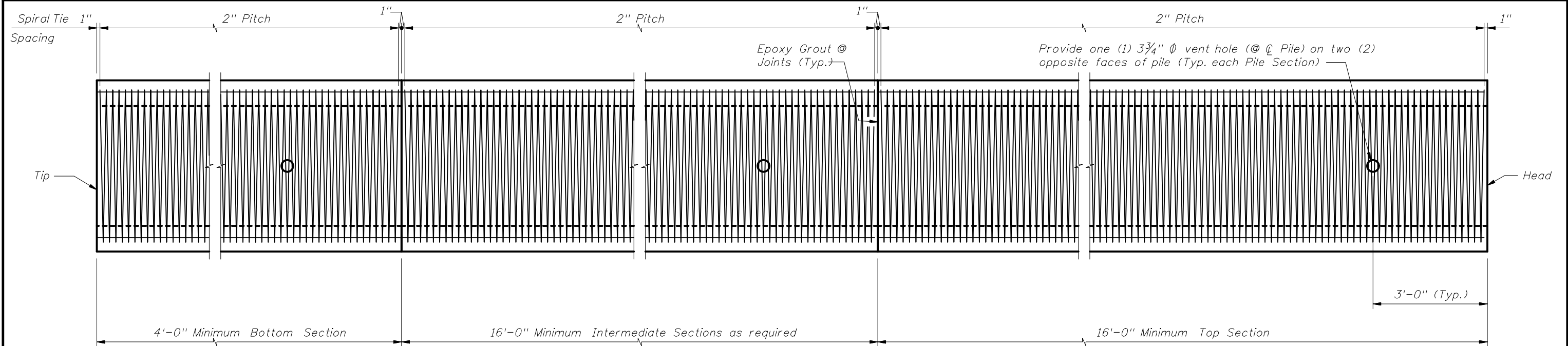

ELEVATION

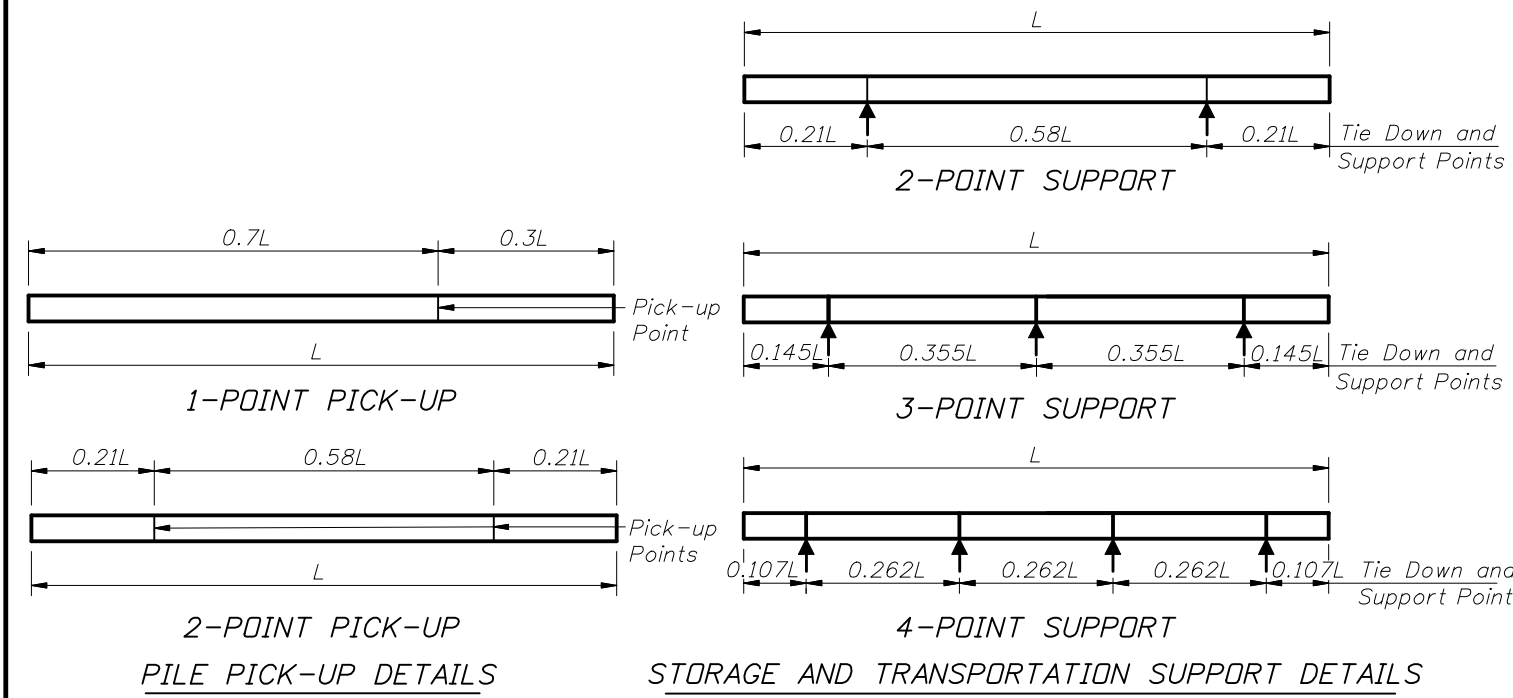

NOTES

**DESIGN SPECIFICATIONS:**  
 Florida Department of Transportation (FDOT) "Structures Design Guidelines", Current Edition.  
 American Association of State Highway and Transportation Officials (AASHTO) "LRFD Bridge Design Specifications", Current Edition.

**DESIGN PARAMETERS:**  
 Prestressed Cylinder Concrete Section: 1,000 psi minimum uniform compression after prestress losses without loads.  
 Pick-up, Storage, and Transportation: 0.0 psi tension w/1.5 times pile self weight.

**SPIRAL TIES:**  
 One full wrap of spirals is required at both the head and tip of pile. One half turn required for spiral splices.

**CONCRETE CLASS:**  
 Concrete for all piles shall be Class V (Special). Concrete for pile splices shall be Class IV. See "GENERAL NOTES" in Structures Plans for any specific locations where the use of Silica Fume is required.

**CONCRETE STRENGTH:**  
 The cylinder strength shall be 6,000 psi minimum at time of transfer of the Prestressing Force.

**SPLICE BONDING MATERIAL:**  
 The material to form the joint between pile sections shall be a Type B Epoxy Compound in accordance with Section 926 of the Specifications. The bonding agent used on internal pile surfaces shall be a Type A Epoxy Compound in accordance with Section 926 of the Specifications. Epoxy Compounds used shall be contained on the Qualified Products List (QPL). Use Epoxy Bonding Compound or Epoxy Mortar as recommended by the Manufacturer. For Epoxy Mortar only use sand or other filler material supplied by the manufacturer and in the proportions recommended.

**PICK-UP POINTS:**  
 Piles shall be marked at the pick-up points to indicate proper points for attaching handling lines.

**REINFORCING STEEL:**  
 All reinforcing steel shall be Grade 60, except that smooth steel wire (W11 spiral ties and longitudinal spacers and W20 ties) shall be manufactured from cold drawn steel wire meeting the requirements of ASTM A82.

**PRESTRESSING STEEL:**  
 Prestressing tendons shall be made up of two seven-wire strands. Prestressing strands shall be 1/2" Ø (Spec.), Grade 270 low relaxation, at 33.8 kips.

**PILE DRIVING AFTER SPLICING:**  
 Pile splices shall reach a minimum strength of 5500 psi before driving is resumed.

Maximum Pile Length (Feet)	Required Storage and Transportation Detail	Pick-Up Detail
119	2, 3, or 4 point	1 Point
170	2, 3, or 4 point	2 Point



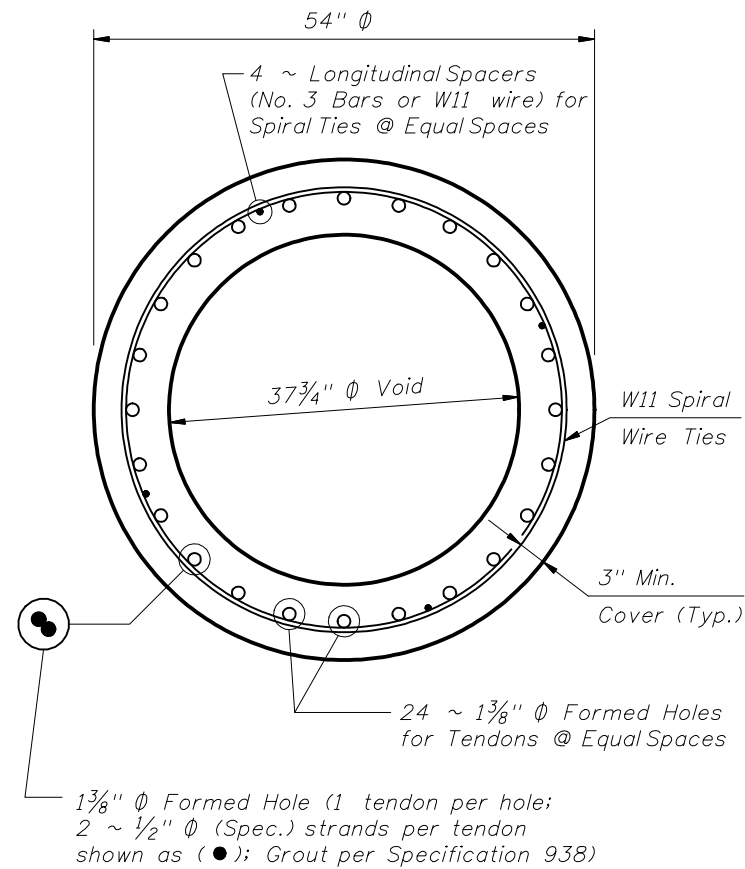
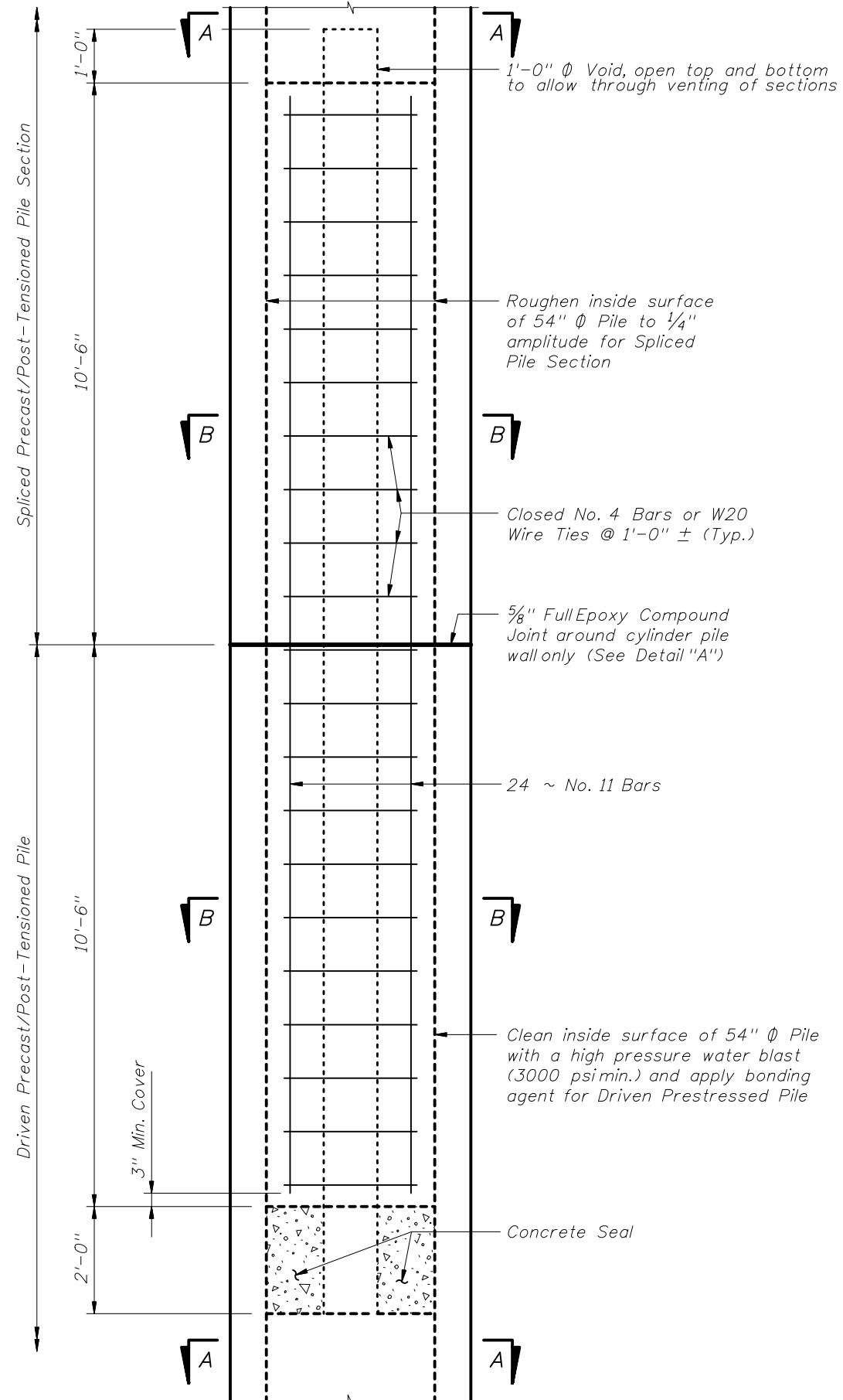

SECTION A-A

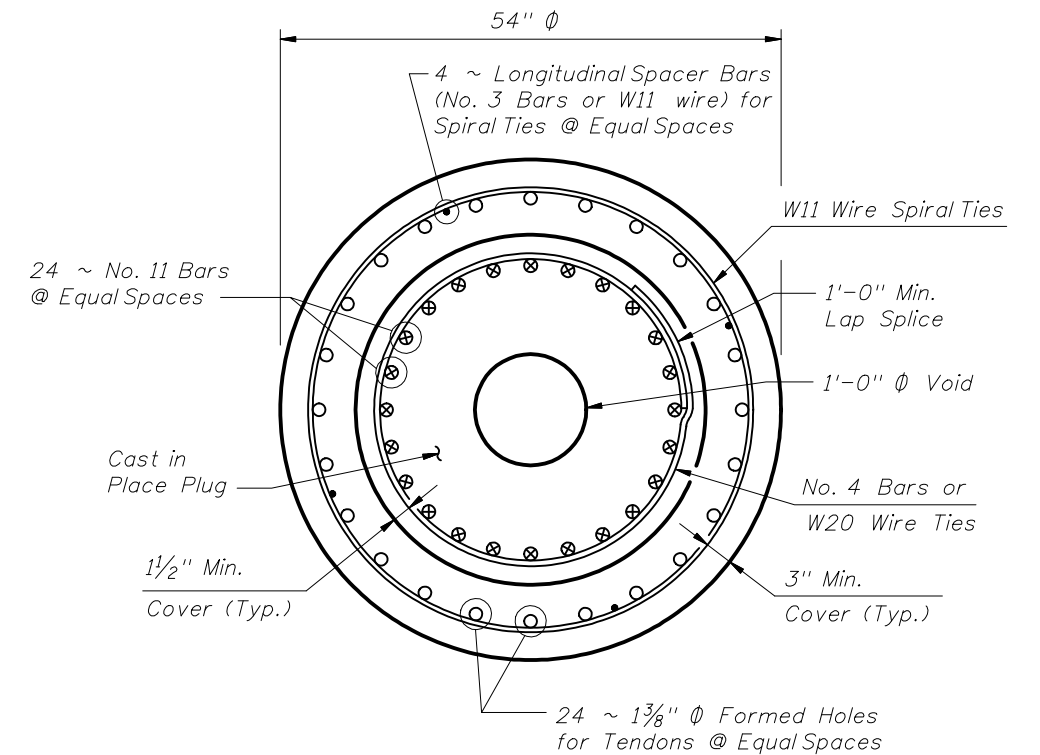

SECTION B-B

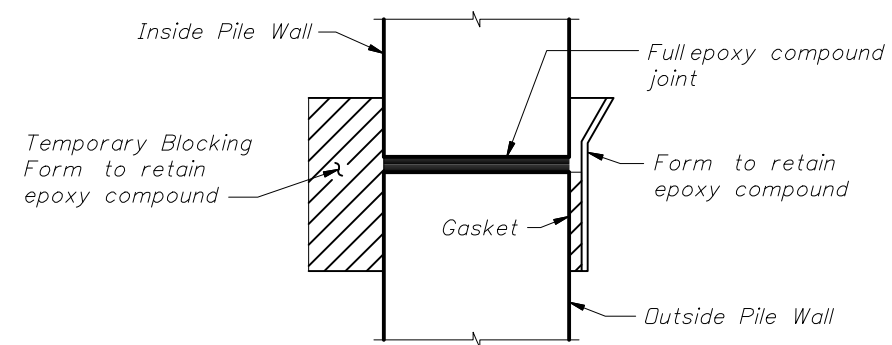

DETAIL "A"



2010 FDOT Design Standards

54" PRECAST/POST-TENSIONED CONCRETE CYLINDER PILE

Last Revision 07/01/07 Sheet No. 2 of 2

Index No. 20654

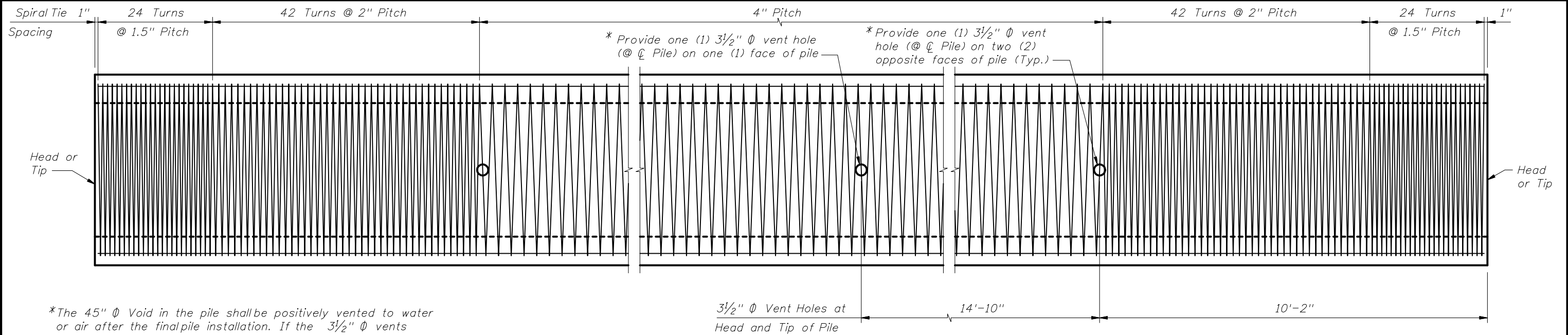

\*The 45"  $\Phi$  Void in the pile shall be positively vented to water or air after the final pile installation. If the 3 1/2"  $\Phi$  vents are included in the pile cut-off section, then venting shall be provided by the use of a 1"  $\Phi$  PVC conduit through the substructure cap or column.

ELEVATION

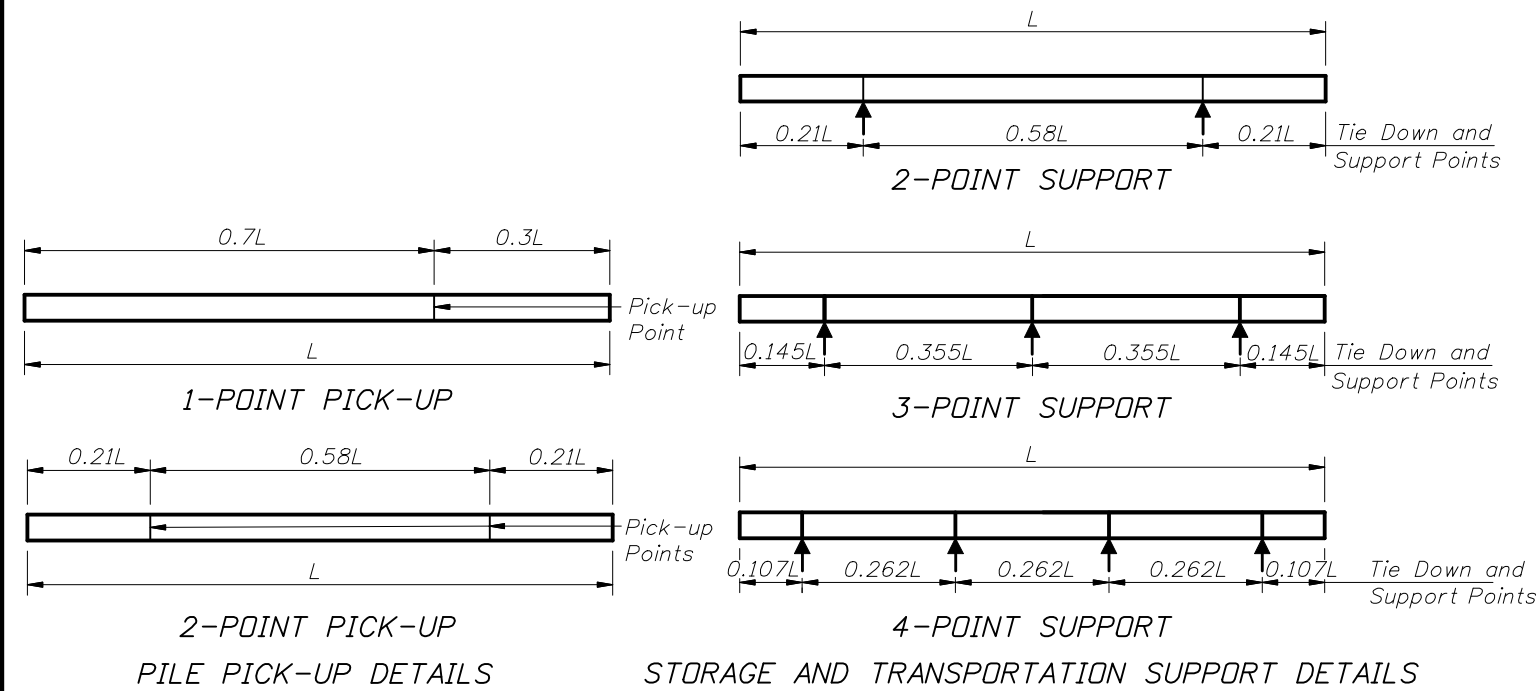

NOTES

- DESIGN SPECIFICATIONS:**  
 Florida Department of Transportation (FDOT) "Structures Design Guidelines", Current Edition.  
 American Association of State Highway and Transportation Officials (AASHTO) "LRFD Bridge Design Specifications", Current Edition.
- DESIGN PARAMETERS:**  
 Prestressed Cylinder Concrete Section: 1,000 psi minimum uniform compression after prestress losses without loads.  
 Pick-up, Storage, and Transportation: 0.0 psi tension w/1.5 times pile self weight.
- SPIRAL TIES:**  
 One full wrap of spirals is required at both the head and tip of pile. One half turn required for spiral splices.
- CONCRETE CLASS:**  
 Concrete for all piles shall be Class V (Special). Concrete for pile splices shall be Class IV. See "GENERAL NOTES" in Structures Plans for any specific locations where the use of Silica Fume is required.
- CONCRETE STRENGTH:**  
 The cylinder strength shall be 4,000 psi minimum at time of transfer of the Prestressing Force.
- SPLICE BONDING MATERIAL:**  
 The material to form the joint between pile sections shall be a Type B Epoxy Compound in accordance with Section 926 of the Specifications. The bonding agent used on internal pile surfaces shall be a Type A Epoxy Compound in accordance with Section 926 of the Specifications. Epoxy Compounds used shall be contained on the Qualified Products List (QPL). Use Epoxy Bonding Compound or Epoxy Mortar as recommended by the Manufacturer. For Epoxy Mortar only use sand or other filler material supplied by the manufacturer and in the proportions recommended.
- PICK-UP POINTS:**  
 Piles shall be marked at the pick-up points to indicate proper points for attaching handling lines.
- REINFORCING STEEL:**  
 All reinforcing steel shall be Grade 60, except that smooth steel wire (W11 spiral ties and W20 ties) shall be manufactured from cold drawn steel wire meeting the requirements of ASTM A82.
- PRESTRESSING STEEL:**  
 Prestressing steel shall be 0.6"  $\Phi$  seven-wire strand, Grade 270 low relaxation, at 44.0 kips.
- PILE DRIVING AFTER SPLICING:**  
 Pile splices shall reach a minimum strength of 5500 psi before driving is resumed.

TABLE OF MAXIMUM PILE PICK-UP AND SUPPORT LENGTHS		
Maximum Pile Length (Feet)	Required Storage and Transportation Detail	Pick-Up Detail
122	2, 3, or 4 point	1 Point
174	2, 3, or 4 point	2 Point



Spliced Prestressed Pile Section

Driven Prestressed Pile

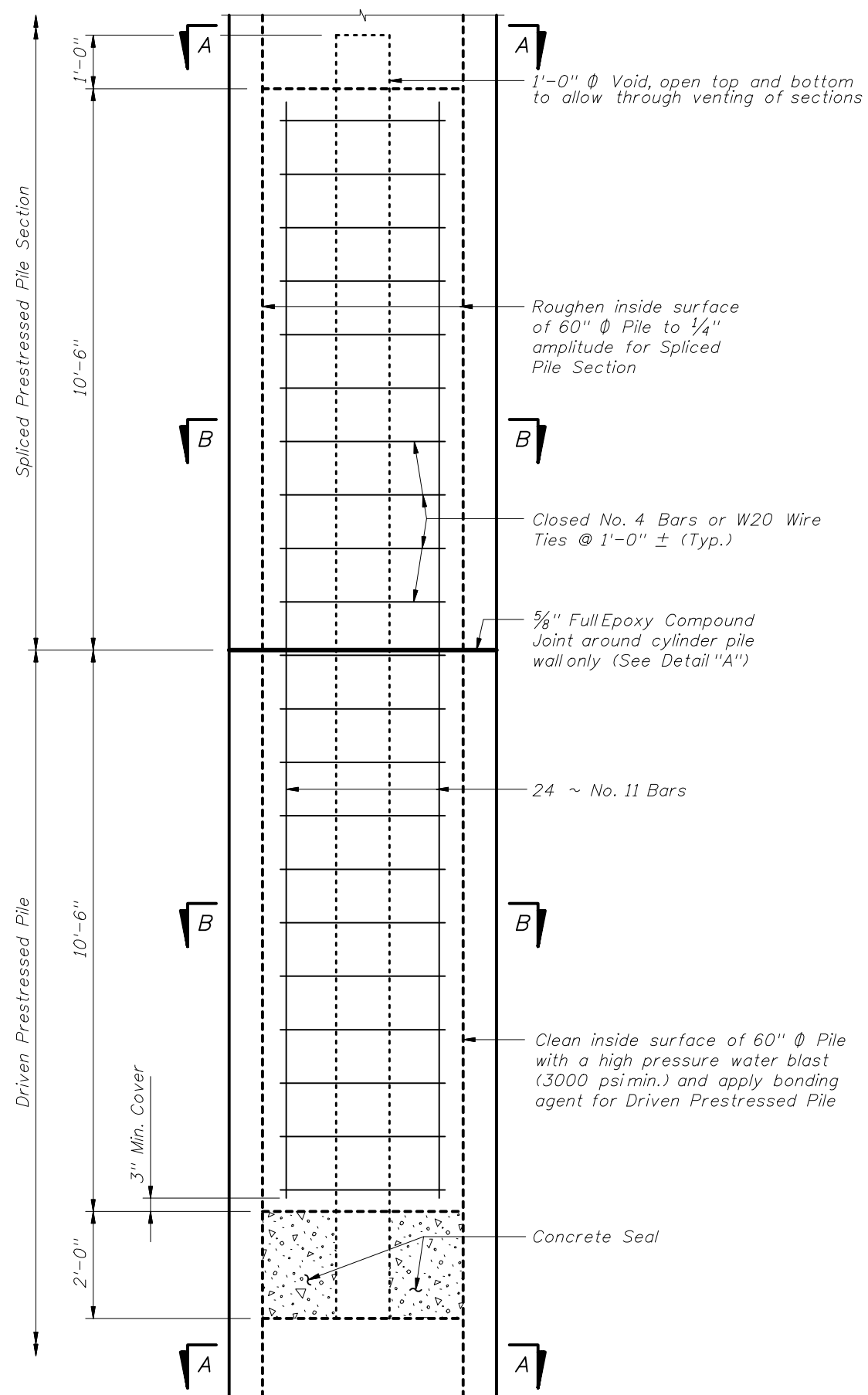

DRIVABLE UNFORESEEN FIELD SPLICE DETAIL  
(Cast in Place Plug)

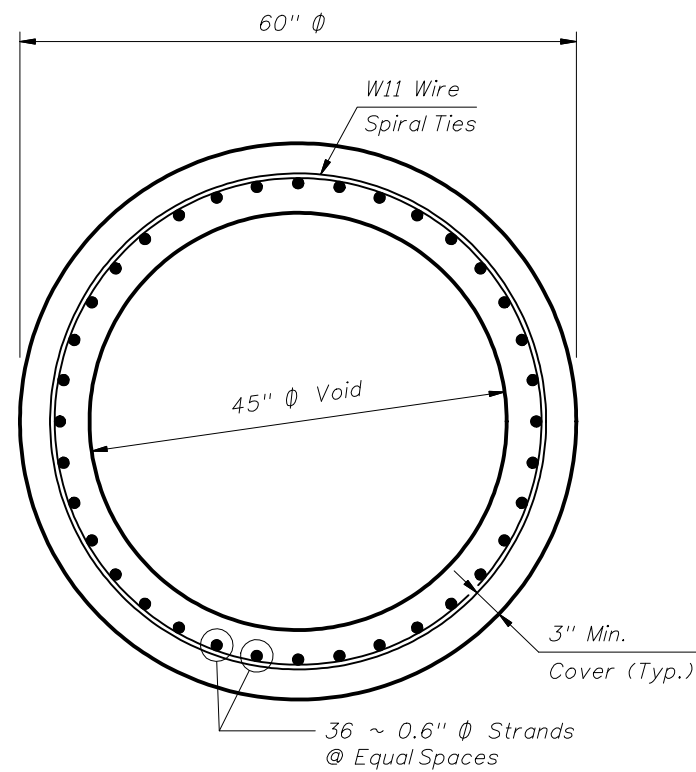

SECTION A-A

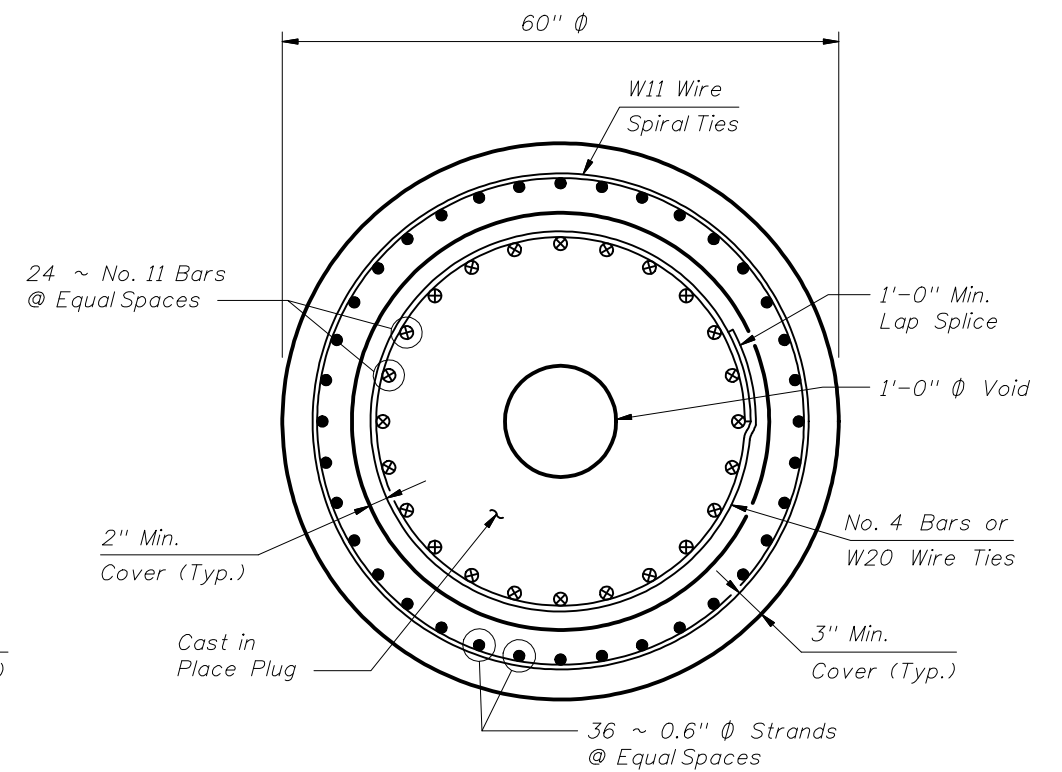

SECTION B-B

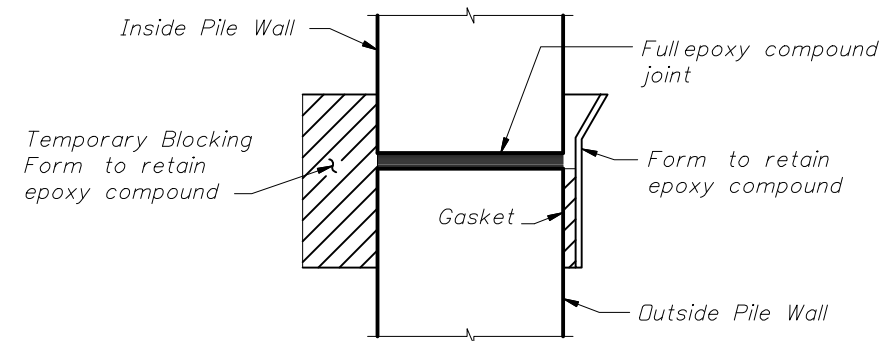

DETAIL "A"



2010 FDOT Design Standards

60" PRESTRESSED CONCRETE CYLINDER PILE

Last Revision	Sheet No.
07/01/07	2 of 2
Index No.	
20660	