

PLAN

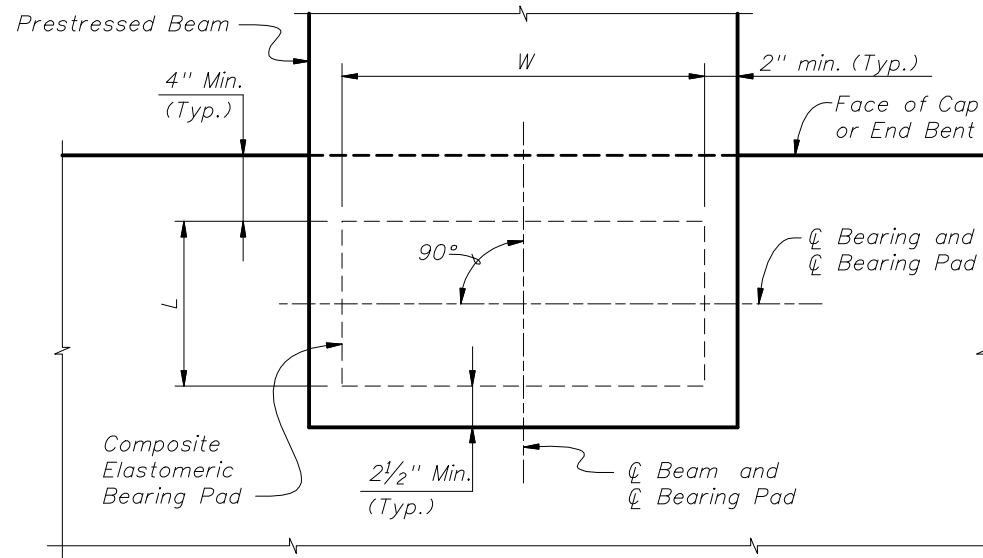

PARTIAL PLAN (Skew = 0°)

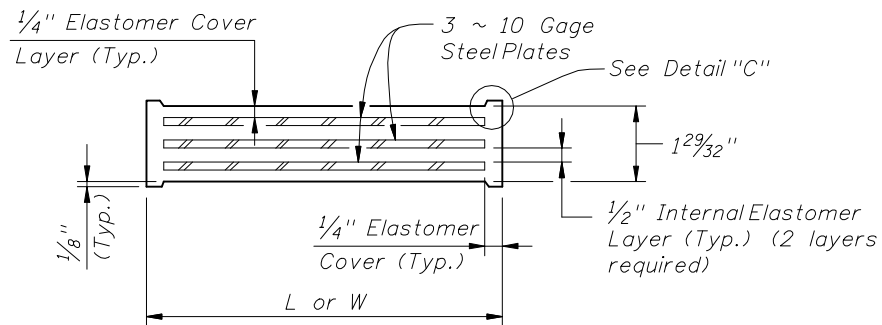

TYPICAL SECTION TYPE A PAD

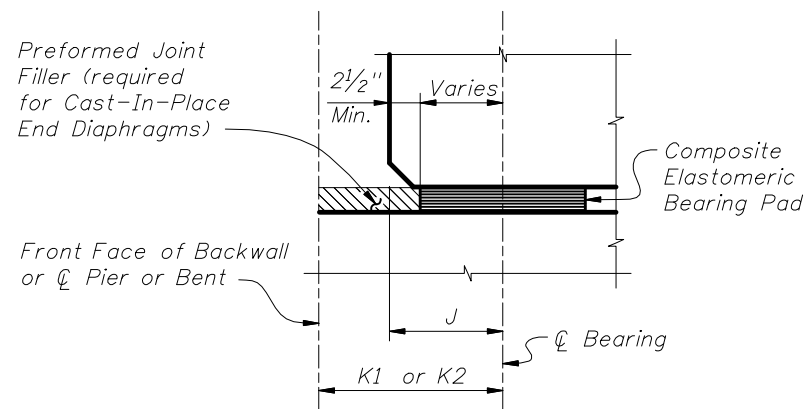

PARTIAL SIDE ELEVATION (ALONG CL BEARING)

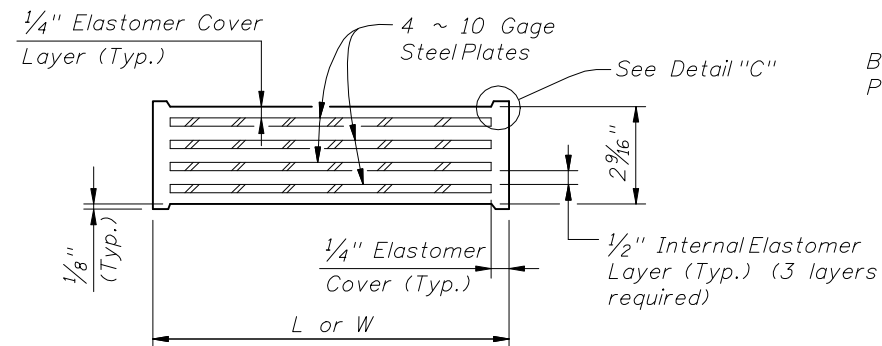

TYPICAL SECTION TYPE B AND TYPE C PAD

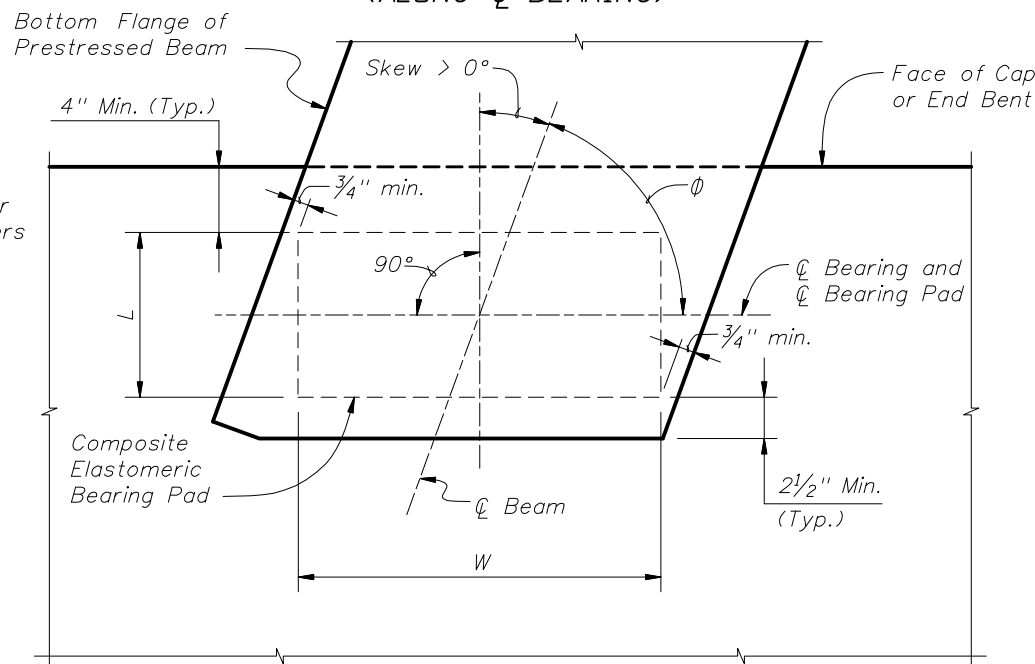

PARTIAL PLAN (Skew > 0°)

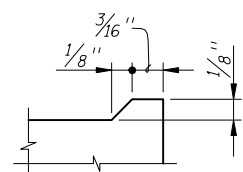

DETAIL "C"

PAD TYPE (See Note 1)	BEAM TYPE	BEARING PAD DIMENSIONS		*BEARING PLATE DIMENSIONS	
		L	W	C	D
A (G=110psi)	II (AASHTO)	1'-0"	1'-2"	1'-2"	1'-4"
	III (AASHTO)	10"	1'-6"	1'-0"	1'-8"
	IV AASHTO)	10"	1'-10"	1'-0"	2'-0"
	V & VI (AASHTO) & FLORIDA BULB-T 78	11"	2'-0"	1'-1"	2'-2"
	FLORIDA BULB-T 72			1'-1"	2'-4"
B (G=110psi)	II (AASHTO)	1'-4"	1'-2"	1'-6"	1'-4"
	III (AASHTO)	1'-2"	1'-6"	1'-4"	1'-8"
	IV AASHTO)	1'-0"	1'-10"	1'-2"	2'-0"
	V & VI (AASHTO) & FLORIDA BULB-T 78	1'-2"	2'-0"	1'-4"	2'-2"
	FLORIDA BULB-T 72			1'-4"	2'-4"
C (G=150psi)	II (AASHTO)	1'-0"	1'-0"	1'-2"	1'-4"
	III (AASHTO)	1'-0"	1'-4"	1'-2"	1'-8"
	IV AASHTO)	10"	1'-9"	1'-0"	2'-0"
	V & VI (AASHTO) & FLORIDA BULB-T 78	1'-0"	1'-11"	1'-2"	2'-2"
	FLORIDA BULB-T 72			1'-2"	2'-4"

* Work this sheet with Index No. 20501 - Bearing Plate Details when beveled or embedded bearing pads are required. See 'TABLE OF BEAM VARIABLES' on Beam Sheets for locations where bearing plates are required.

BEARING PAD NOTES:

1. Neoprene in Type A or B bearing pads shall have a shear modulus (G) of 110 psi. Neoprene in Type C bearing pads shall have a shear modulus (G) of 150 psi.
2. Steel Plates in bearing pads shall conform to ASTM A1011 Grade 36, Type 1.
3. Variations in pad dimensions will be allowed provided the revised pads meet the Specifications, meet the requirements of this index, and are approved by the Engineer.
4. For beam grades less than or equal to 2% finish the Beam Seat parallel to the bottom of the beam. For beam grades greater than 2% finish the Beam Seat level and provide Beveled Bearing Plates.
5. See Bid Item Notes for quantities of Type A, B, and/or C Bearing Pads.

