

ORIENTATION VIEW

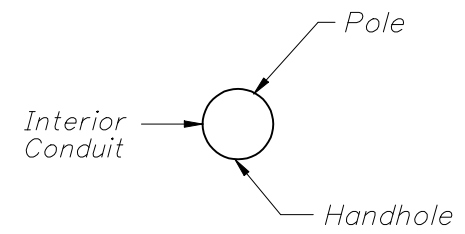

ORIENTATION VIEW

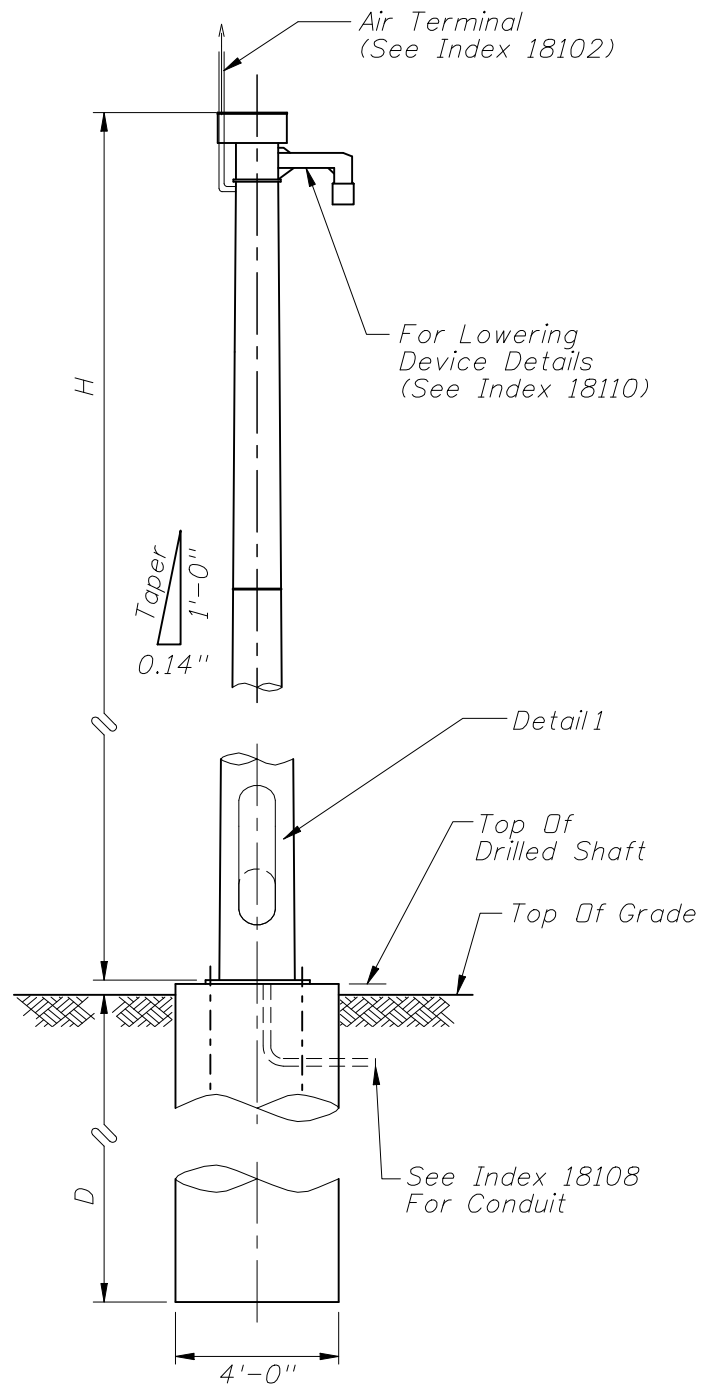

WITH LOWERING DEVICE

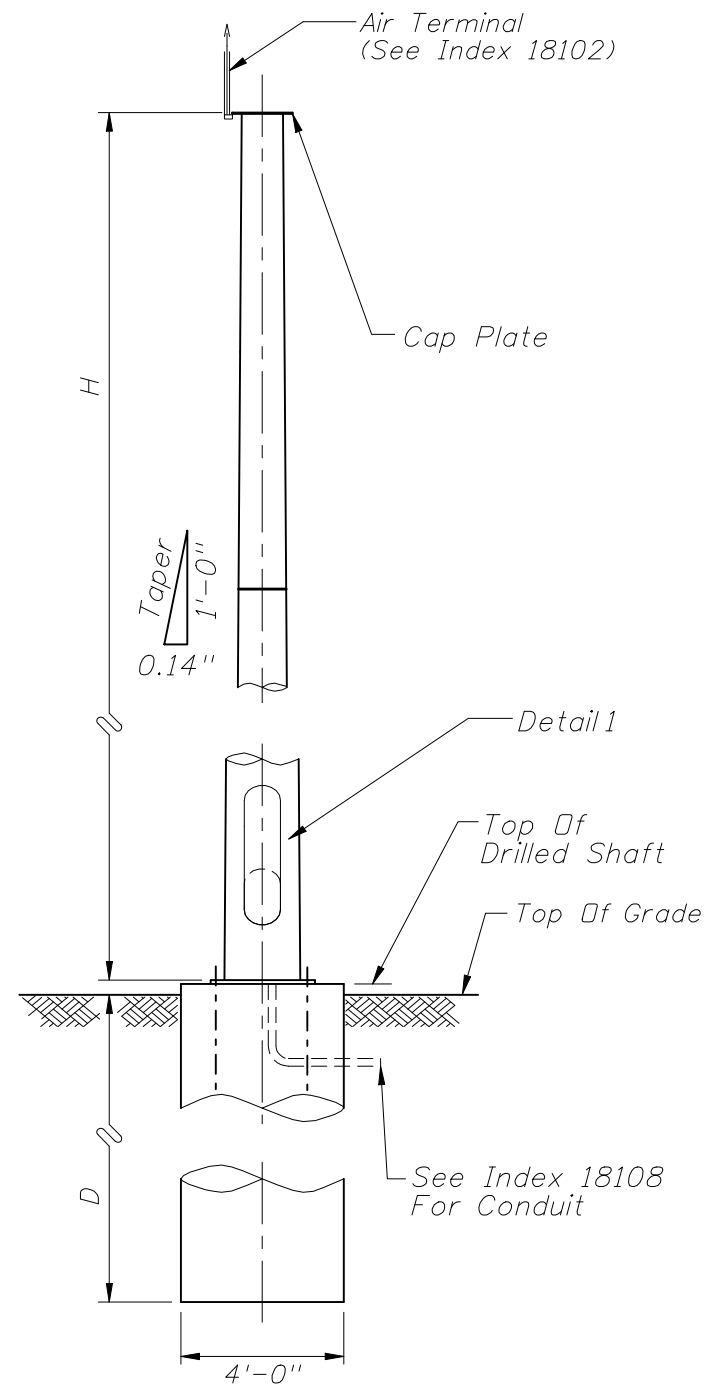

WITHOUT LOWERING DEVICE

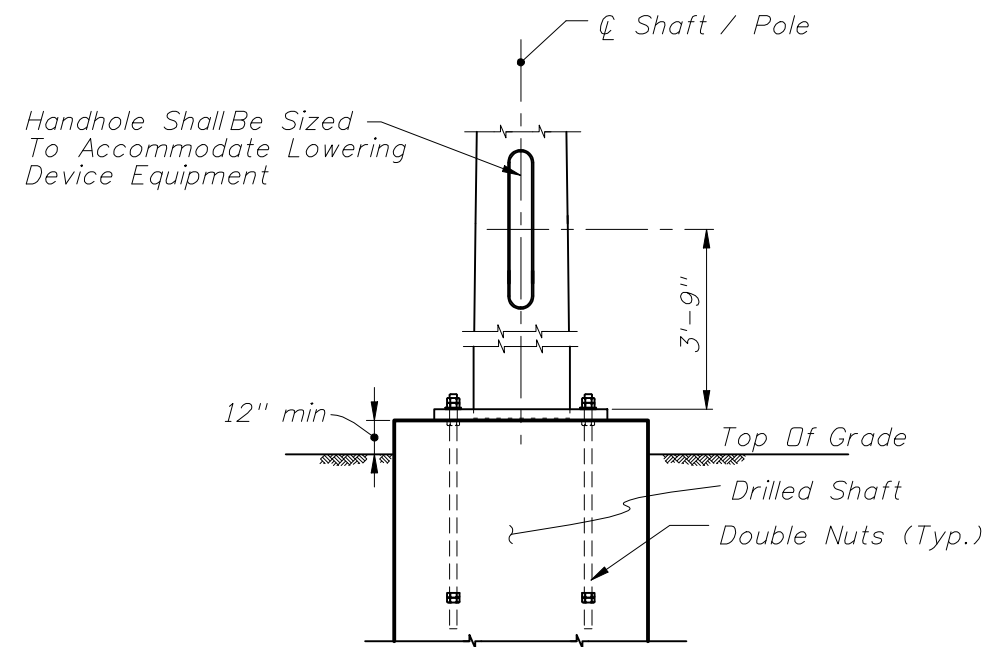

DETAIL 1

H (ft)	D (ft)
50	8
55	8.5
60	9
65	9.5
70	10

Not To Scale

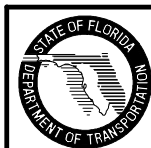

2010 FDOT Design Standards

STEEL CCTV POLE

Last Revision	Sheet No.
01/01/09	1 of 2
Index No.	
18111	

DESIGN NOTES:

Design according to FDOT Structures Manual (current edition) and the AASHTO "Standard Specifications for Structural Supports for Highway Signs, Luminaires and Traffic Signals" 5th Edition with Interims.

Maximum 1" deflection in 40mph wind (3 second gust).

Manufacturers seeking approval for inclusion on the Qualified Products List must submit a QPL Production Evaluation Application along with design documentation and drawings showing pole and foundation meet all specified requirements of this Standard.

Perform all welding in accordance with the American Welding Society Structural Welding Code (Steel) ANSI/AWS D1.1 (current edition).

Foundation Materials:

Reinforcing Steel: ASTM A615 Grade 60

Concrete: Class V Special or Class VI with 4 ksi minimum strength at transfer.

Anchor Bolts: ASTM F1554 Grade 55 with ASTM A563 Grade A heavy-hex nuts.

ASTM F436 Type 1 washers.

ASTM F2329 galvanization.

Foundation design based upon the following soil criteria:

Classification = Cohesionless (Fine Sand)

Friction Angle = 30 Degrees (30°)

Unit Weight = 50 lbs./cu. Ft. (assumed saturated)

Only in cases where the Designer considers the soil types at the specific site location to be of lesser strength properties should an analysis be required. Auger borings, SPT borings or CPT soundings may be utilized as needed to verify the assumed soil properties, and at relatively uniform sites, a single boring or sounding may cover several foundations. Furthermore, borings in the area that were performed for other purposes may be used to confirm the assumed soil properties.

Pole:

Round or 16 sided.

Tapered 0.14 inches per foot.

Transverse welds only allowed at the base.

Two or more sections with overlapping splices not permitted.

No laminated tubes.

Only one longitudinal seam weld permitted.

Longitudinal seam welds within 6" of complete penetration pole to base welds shall be complete penetration welds.

Identification tag:

Aluminum, secured to pole with stainless steel screws.

Locate inside pole and visible from handhole.

Provide Financial Project ID, pole height, manufacturer's name & certification number, and QPL number.

Pole Specifications:

ASTM A1011 Grade 50, 55, 60 or 65 (less than 1/4") or

ASTM A572 Grade 50, 60 or 65 (greater than 1/4") or

ASTM A595 Grade A (55 ksi yield) or Grade B (60 ksi yield).

Steel Plates and Pole Cap: ASTM A36.

Weld Metal: E70XX.

Bolts: ASTM A325, Type 1.

Handhole frame: ASTM A709 Grade 36 or ASTM A36.

Handhole cover: ASTM A1011 Grade 50, 55, 60 or 65.

Stainless steel screws: AISI Type 316.

Galvanization:

Nuts, bolts and washers: ASTM F2329.

All other steel: ASTM A123.

One hundred percent of full-penetration groove welds and a random 25% of partial penetration groove welds shall be inspected. Full-penetration groove weld inspection shall be performed by nondestructive methods of radiography or ultrasonics.

INSTALLATION NOTES:

Cable Supports: Electrical Cable Guides and Eyebolts.

Locate top and bottom electrical guides within the pole aligned with each other.

Position one cable guide 2" below the handhole.

Position other cable guide 1" directly below the top of the tenon.

Position eyebolt 2-3/4" below the top of the handhole.

Install pole plumb.

Lowering Device Installation Notes:

Design tenon dimensions to facilitate lowering device component installation. Locate slots parallel to the pole centerline for mounting the lowering device. Bolt a tenon to the pole top with mounting holes and slot as required for the mounting of the lowering device.

Place all electrical wire in interior conduit to prevent them from interfering with or being damaged by the lowering cable that moves within the pole.

Mount lowering arm perpendicular to the roadway or as shown in the plans.

Position CCTV pole so that the camera can be safely lowered without requiring lane closures.

Include a lowering device (including top J-box), mounting hardware, lowering cable, contact block, waterproof electrical connectors, camera J-box and housing.



2010 FDOT Design Standards

STEEL CCTV POLE

Last Revision

01/01/09

Sheet No.

2 of 2

Index No.

18111