

SIDE VIEW
DAMPING DEVICE

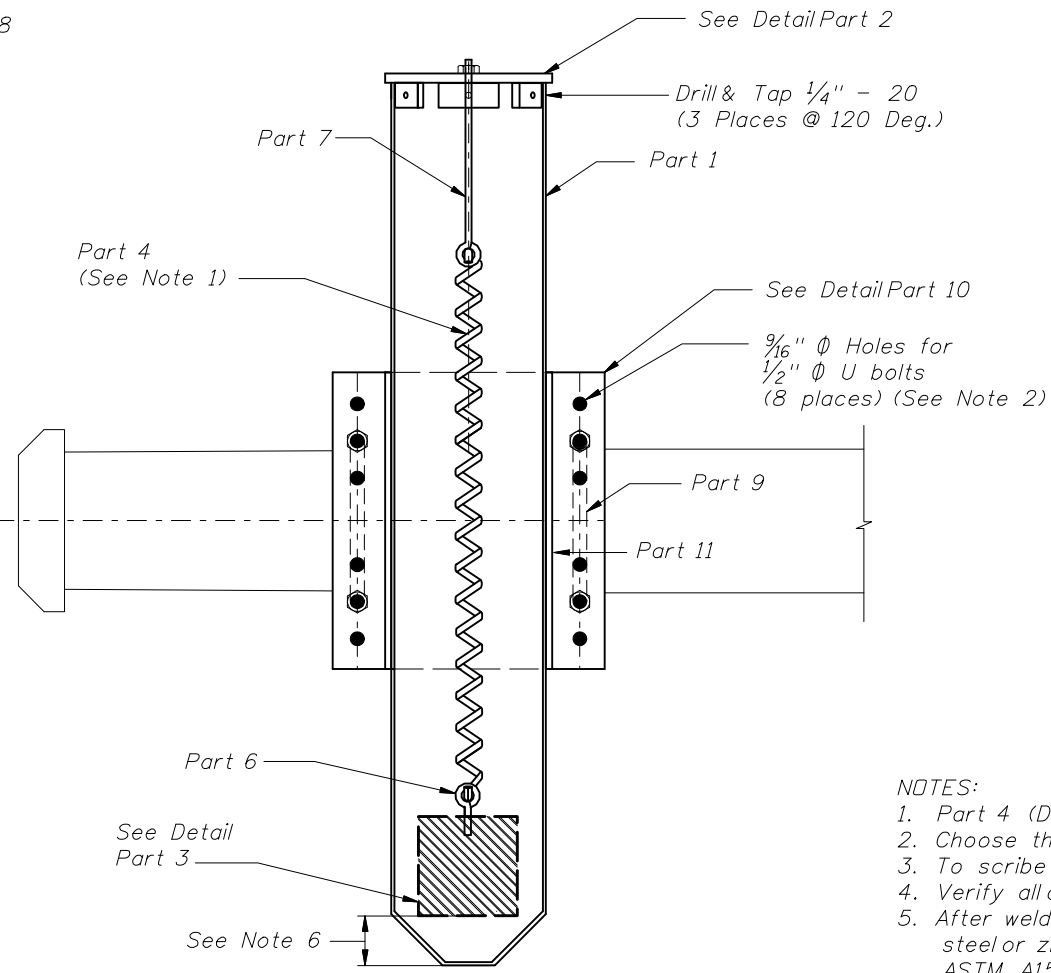

SECTION A-A

#	PART	PART DESCRIPTION	QUANTITY
1	Damper Tube	6" ID, 3'-6" long before fabrication, t=0.125", ASTM A513, Type 1	1
2	Tube Cap	Cap Assembly, 1/4" Steel plate, ASTM A36	1
3	Internal Weight	4"Ø, 15 lb. cylindrical, steel weight, ASTM A36.	1
4	Damper Spring	Century Spring (Spring Stock #147) Stiffness= 0.69 lb/in, length = 8.05", OD= 1.062"	1
5	Hex Nut	1/4" - 20 steel hex nut (zinc plated)	1
6	Eye Bolt	1/4"x2" Steel Eye Bolt (zinc plated)	1
7	Eye Bolt	1/4"x8" Steel Eye Bolt (zinc plated)	1
8	Cap Screw	#8 2'-8"x3"x3/4" Stainless Steel Machine Screws (Flat Head Phillips)	4
9	U Bolt	1/2" Ø ASTM, A307 with washers and 4 self locking nuts (Size to fit Mast Arm)	2
10	1/4" Plate	1'-0"x11", ASTM A36	1
11	1/4" Plate	1'-0"x4 1/8" ASTM A36 (Weld to Part 1 and Part 10)	2

- NOTES:
- Part 4 (Damper Spring) is shown schematically and not to scale.
 - Choose the appropriate diameter U-bolt (Part 9) based on the structure's pipe arm diameter.
 - To scribe tube for taper, wrap template around tube such that points are 2'-9 5/8" from top of tube.
 - Verify all clearances, tolerances and dimensions before fabrication.
 - After welding, hot dip galvanize all steel items except screws, bolts, and nuts noted to be stainless steel or zinc plated, and the spring (Part 4). Galvanize bolts, nuts and washers in accordance with ASTM A153. Galvanize all other items in accordance with ASTM A123.
 - Install spring with 2" separation from bottom of pipe to weight at rest.

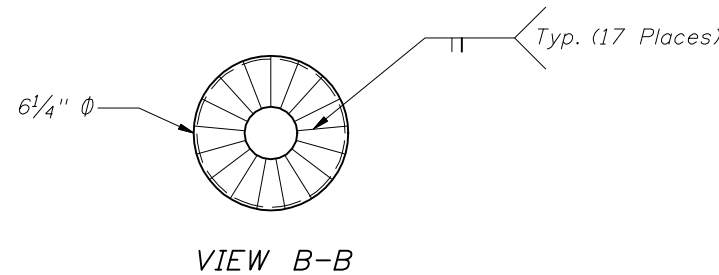

VIEW B-B

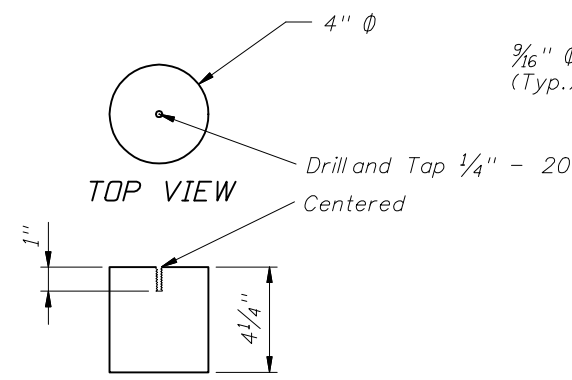

SIDE VIEW
PART 3
INTERNAL WEIGHT

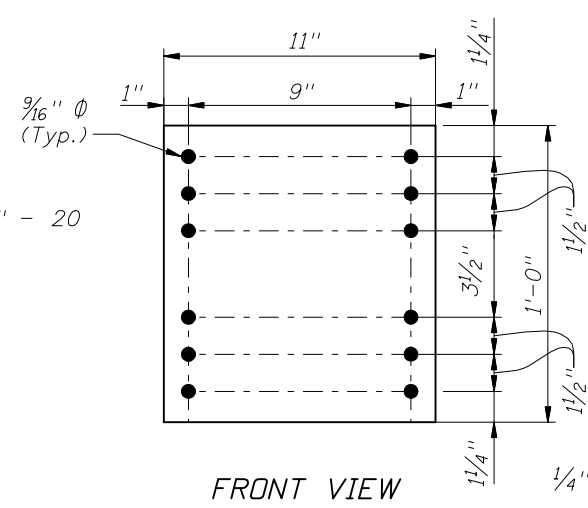

FRONT VIEW
PART 10
BACKING PLATE

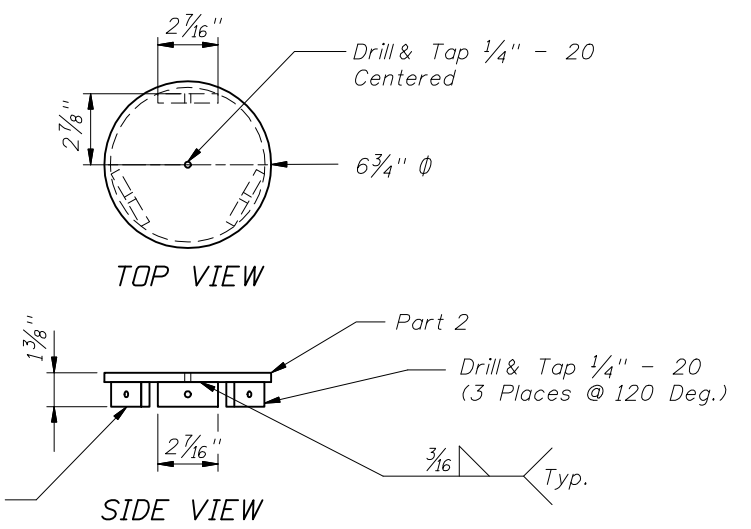

SIDE VIEW
PART 2
TUBE CAP

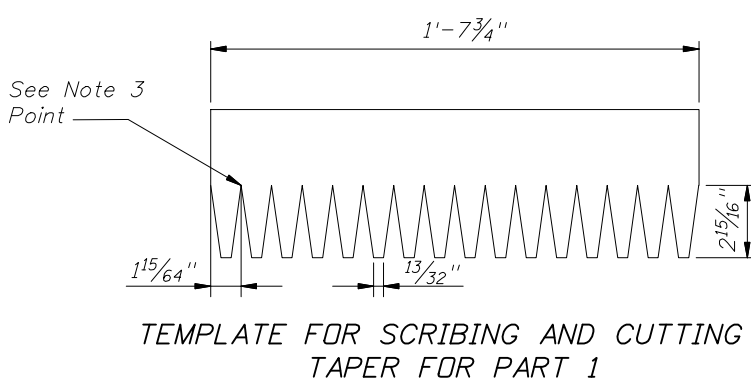

TEMPLATE FOR SCRIBING AND CUTTING
TAPER FOR PART 1

