

TYPE A (WELDED)

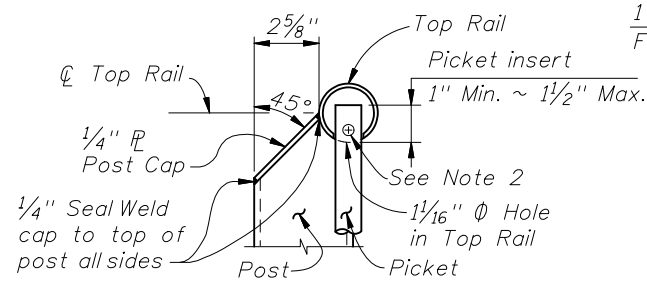

TYPE B (NONWELDED)

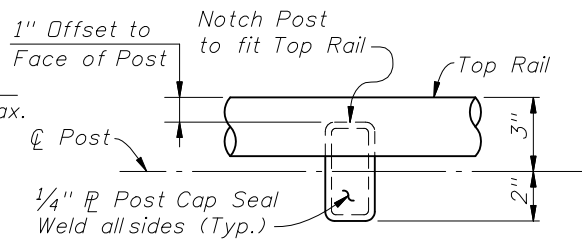

VIEW F-F
TOP RAIL CONNECTION
(Base Plate Not Shown for Clarity)

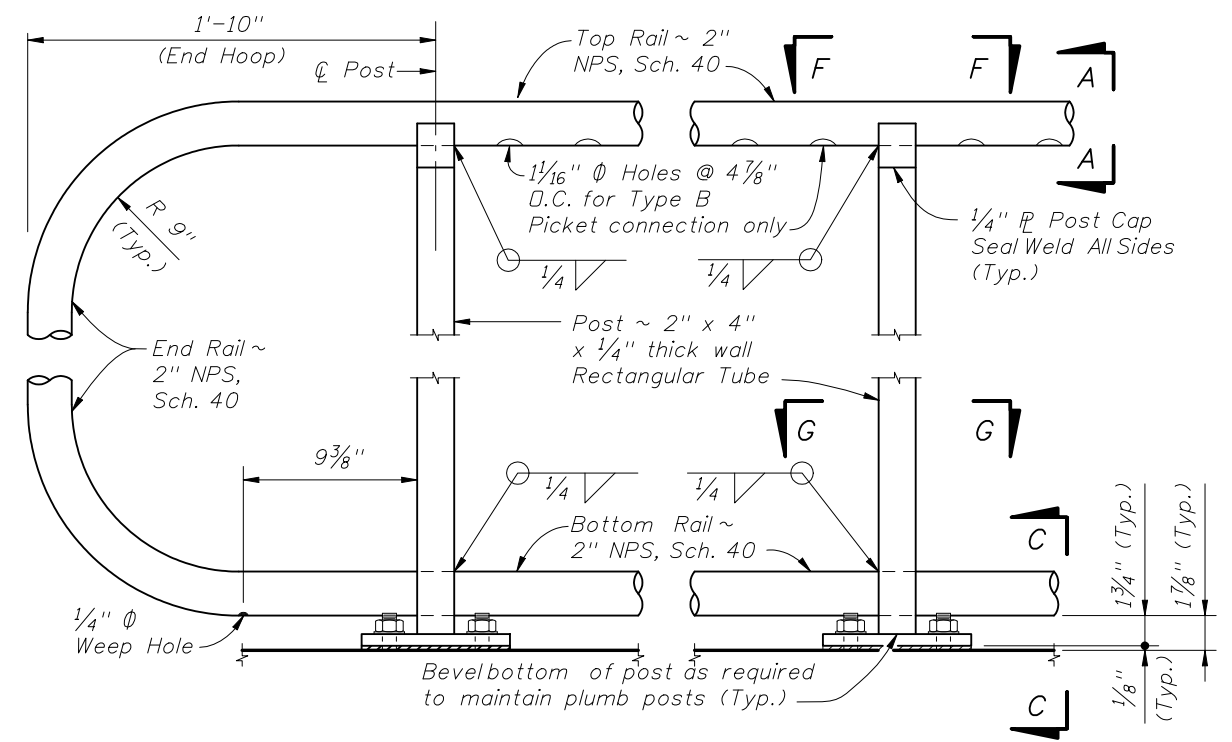

DETAIL "C" - RAIL CONNECTIONS
(Showing Outside Face of Structure and Railing, Pickets and Handrail Not Shown for Clarity)

SECTION A-A
(Top of Picket Connection)

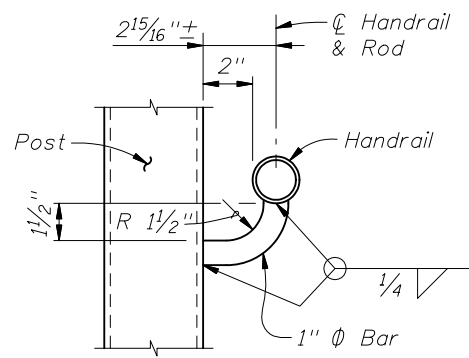

SECTION B-B
(Handrail Connection)

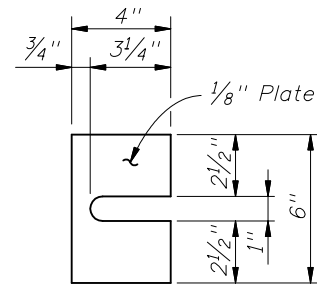

SHIM PLATE
DETAIL

Notes:

1. Type B connection is required for use with Index No. 861 on bridges, except End Hoops may use Type A connections. Optional for other installations and for connection to bottom rail.
2. Provide #10 x 1/2" Pan Head Stainless Steel (316 or 18-8 Alloy) Screw in the last picket at each expansion or field splice joint to secure the end of the top rail.

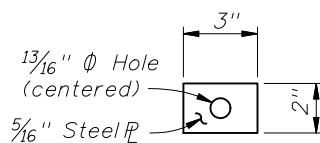
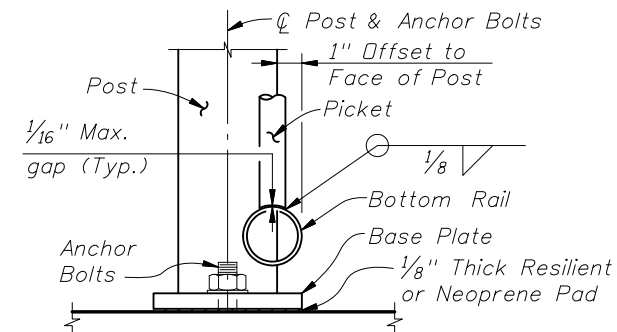
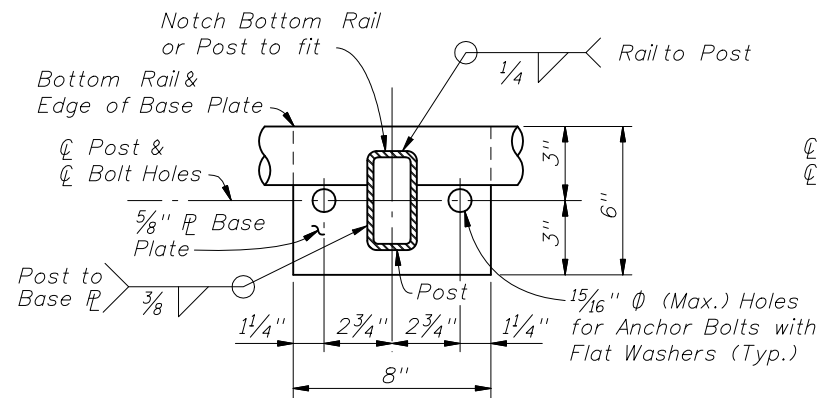

PLATE WASHER
DETAIL



SECTION C-C
(Bottom of Picket connection)



SECTION G-G
BASE PLATE & BOTTOM RAIL CONNECTION

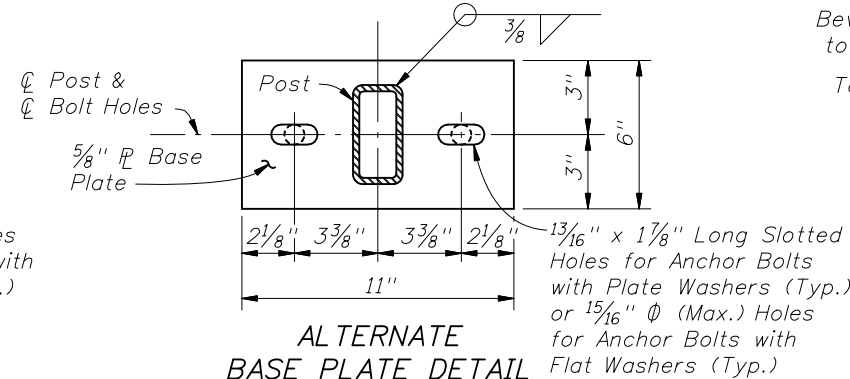

ALTERNATE
BASE PLATE DETAIL
(Recommended for Top of Step Cheekwalls)

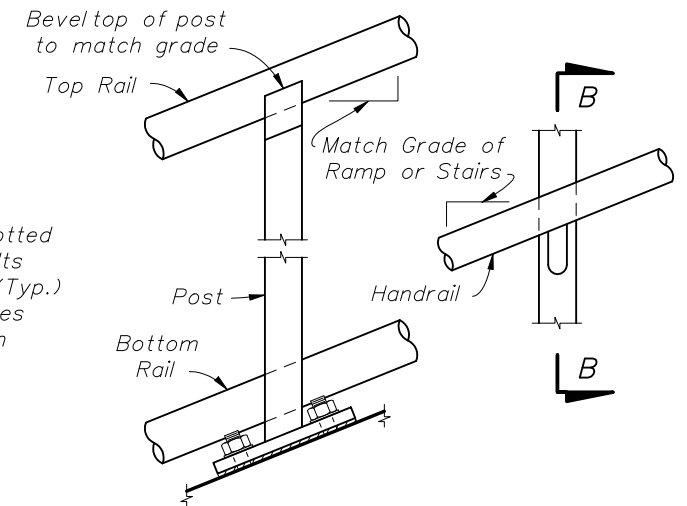

DETAIL "B" - RAIL AND HANDRAIL
(Showing Sloped Condition for Stairs or Ramp)

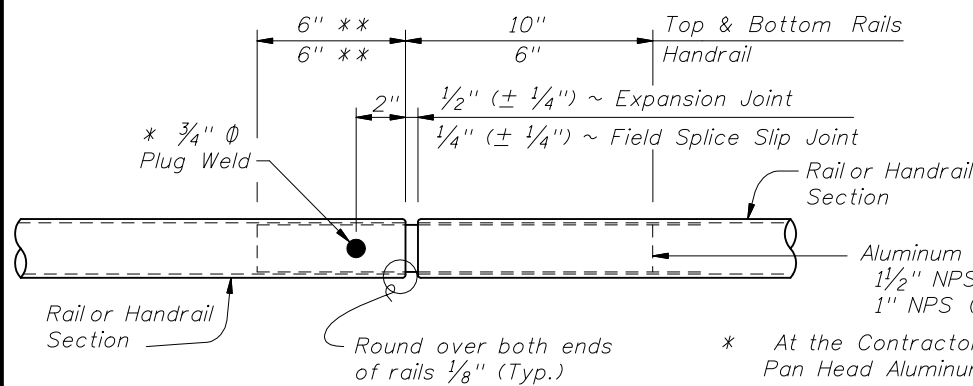

DETAIL "D" - EXPANSION JOINT
(FIELD SPLICE SLIP JOINT SIMILAR)

- * At the Contractor's option 2 ~ 1/4" diameter x 3/4" Pan Head Aluminum (Alloy 2024-T4 or 7075-T73) or Stainless Steel (Type 316 or 18-8 Alloy) Set Screws at 2" spacing may be substituted for the 3/4" diameter plug weld. Set screws must be set flush against the outside face of rails and underside of handrails.
- ** Embedded length may be 4" for plug welded connection.

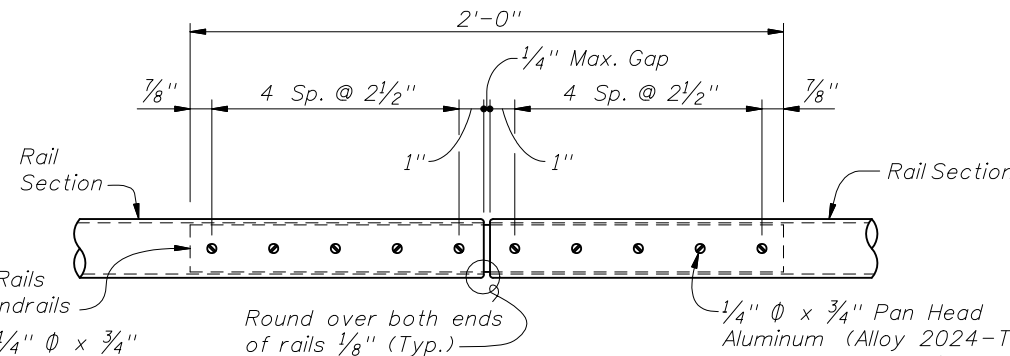

DETAIL "E" - CONTINUITY
FIELD SPLICE

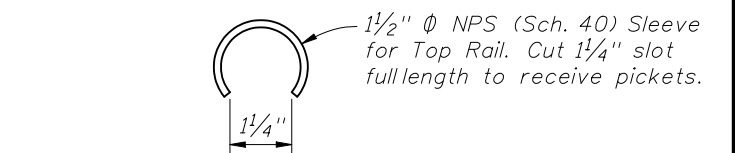

SLEEVE MODIFICATION FOR
TOP RAIL TYPE B CONNECTION

CROSS REFERENCE:
For locations of Details "C", "D" and "E", see Sheet 2 of 5.

REVISIONS

DATE	BY	DESCRIPTION	DATE	BY	DESCRIPTION
01/01/08	SJN	Added requirement for set screw to be set flush against outside face of rail, 18-8 Alloy option in DETAILS "D" & "E" and TYPE B (NONWELDED) Detail, and 1/4" joint tolerance in Detail "D".	07/01/09	SJN	Changed 1'-0" embedment of Rail Expansion Joint Sleeve to 10". Changed picket weld size to 1/8", bottom rail weld size to 1/4", base plate weld size to 3/8" and note 1.

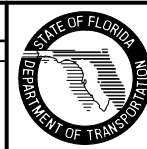

2008 Interim Design Standard

ALUMINUM PEDESTRIAN/BICYCLE PICKET RAILING

Interim Date	Sheet No.
07/01/09	4 of 5
Index No.	
860	