

GENERAL NOTES

- Details apply to both rural and urban intersections under stop sign control or flashing beacon control. For full signal controlled intersections see Design Note No. 4.
- Sight distance (d) applies to normal and skewed intersections (intersecting angles between 60° and 120°), and where vertical and/or horizontal curves are present. Sight distance (d) is measured along the major roadway from the center of the entrance lane of the minor roadway to the center of the near approach lane (right or left) of the major roadway. Distances d_L and d_R are measured from the centerline of the entrance lane of the minor roadway to a point on the edge of the near side outer traffic lane on the major roadway. Distance d_M is measured from the centerline of the entrance lane of the minor roadway to a point on the median clear zone limit or horizontal clearance limit for the far side roadway of the major roadway.
- The limits of clear sight define a corridor throughout which a clear sight window must be preserved. See WINDOW DETAIL, Sheet 2.
 - Clear sight must be provided between vehicles at intersection stop locations, and vehicles on the major roadway within dimension 'd'.
 - Since observations are made in both directions along the line of sight, the reference datum between roadways is 3'-6" above respective pavements.
- Barrier systems within intersection sight corridors, where penetration into the sight window might occur, shall be located to provide the least adverse affect practical.
- The corridor defined by the limits of clear sight is a restricted planting area. Drivers of vehicles on the intersecting roadway and vehicles on the major roadway must be able to see each other clearly throughout the limits of 'd' and 'd_a'. If in the Engineers judgement, landscaping interferes with the line of sight corridor prescribed by these standards the Engineer may rearrange, relocate or eliminate plantings. Plants within the restricted areas are limited to selections as follows:

Ground Cover & Trunked Plants (Separate or Combined):

Ground Covers – Plant selection of low growing vegetation which at maturity does not attain a height greater than 18" below the sight line datum.

For ground cover in combination with trees and palms; the following heights below the sight line datum will apply: 24" for trees and palms ≤ 11" dia.; and, 18" for sabalpalms > 11" ≤ 18" dia. (dia. – within Sight Window).

Trunked Plants – Plant selection of a mature trunk diameter 4" or less measured at 6" above the ground. Canopy or high borne foliage shall never be lower than 5' above the sight line datum. These selections shall be spaced no closer than 20'.

Trees:

Trees can be used with lawn; pavers; pavement; gravel, bark or wood chip beds; ground covers or other Department approved material. The clear sight window must be in conformance with the 'WINDOW DETAIL' modified to attain the height requirements listed in 'Ground Covers' above. Tree size and spacing shall conform to the following tabular values:

Description	Speed (mph)													
	30	35	40	45	50	55	60	30	35	40	45	50	55	60
	(Inches)													
Diameter (Within Limits Of Sight Window)	>4≤11	>11≤18	>4≤11	>11≤18	>4≤11	>11≤18	>4≤11	>11≤18	>4≤11	>11≤18	>4≤11	>11≤18	>4≤11	>11≤18
	(Feet)													
Minimum Spacing (c. to c. Of Trunk)	22	91	27	108	33	126	40	146	45	165	52	173	60	193

Sizes and spacings are based on the following conditions:

- A single line of trees in the median parallel to but not necessarily colinear with the centerline,
- A straight approaching mainline, within skew limits as described in No. 2 above.
- Trees and palms ≤ 11" in diameter casting a vertical 6' wide shadow band on a vehicle entering at stop bar location when viewed by mainline driver beginning at distance 'd'; see SHADOW DIAGRAM, Sheet 2.
 - Sabalpalms with diameters > 11" to ≤ 18" spaced at intervals providing a 2 second full view of entering vehicle at stop bar location when viewed by mainline driver beginning at distance 'd'; see PERCEPTION DIAGRAM, Sheet 2.
- Trees with diameters ≤ 11" intermixed with trees with diameters > 11" ≤ 18" are to be spaced based on trees with diameters > 11" ≤ 18".

For any other conditions the tree sizes, spacings and locations shall be detailed in the plans; see Design Note No. 5.

DESIGN NOTES

- The information shown on this index is intended solely for the purpose of clear sight development and maintenance at intersecting highways, roads and streets, and is not intended to be used to establish roadway and roadside safety except as related to clear sight corridors. An analysis of sight distance shall be documented for all intersections.
- Details are based on the AASHTO 'A Policy On Geometric Design Of Highways And Streets, 2001', CHAPTER 9, INTERSECTION SIGHT DISTANCE, CASES B and F, and Department practices for channelized median openings (left turns from major roadways).
- The minimum driver eye setback of 14.5' from the edge of the traveled way may be adjusted on any intersection leg only when justified by a documented, site specific field study of vehicle stopping position and driver eye position.
- For SIGNALIZED INTERSECTIONS sight distances should be developed based on AASHTO 'Case D- Intersections With Traffic Signal Control'. 'At signalized intersections, the first vehicle stopped on one approach should be visible to the driver of the first vehicle stopped on each of the other approaches. Left-turning vehicles should have sufficient sight distance to select gaps in oncoming traffic and complete left turns. Apart from these sight conditions, there are generally no other approach or departure sight triangles needed for signalized intersections. However, if the traffic signal is to be placed on two-way flashing operation (i.e. flashing yellow on the major-road approaches and flashing red on the minor-road approaches) under off-peak or nighttime conditions, then the appropriate departure sight triangles for Case B, both to the left and to the right, should be provided for the minor-road approaches. In addition, if right turns on a red signal are to be permitted from any approach, then the appropriate departure sight triangle to the left for Case B2 should be provided to accommodate right turns from that approach.'
- Where curvature, superelevation, adverse split profiles or other conditions preclude the use of standard tree sizes and spacing, proof of view and shadowing restraints must be documented and the size and location of trees in medians detailed in the plans.
- Intersection sight distance values are provided for Passenger Vehicles, SU Vehicles and Combination Vehicles. Intersection sight distance based on the Passenger Vehicle is suitable for most intersections. Where substantial volumes of heavy vehicles enter the major-road, such as from ramp terminals with stop control or roadways serving truck terminals, the use of tabulated values for SU Vehicles or Combination Vehicles should be considered.

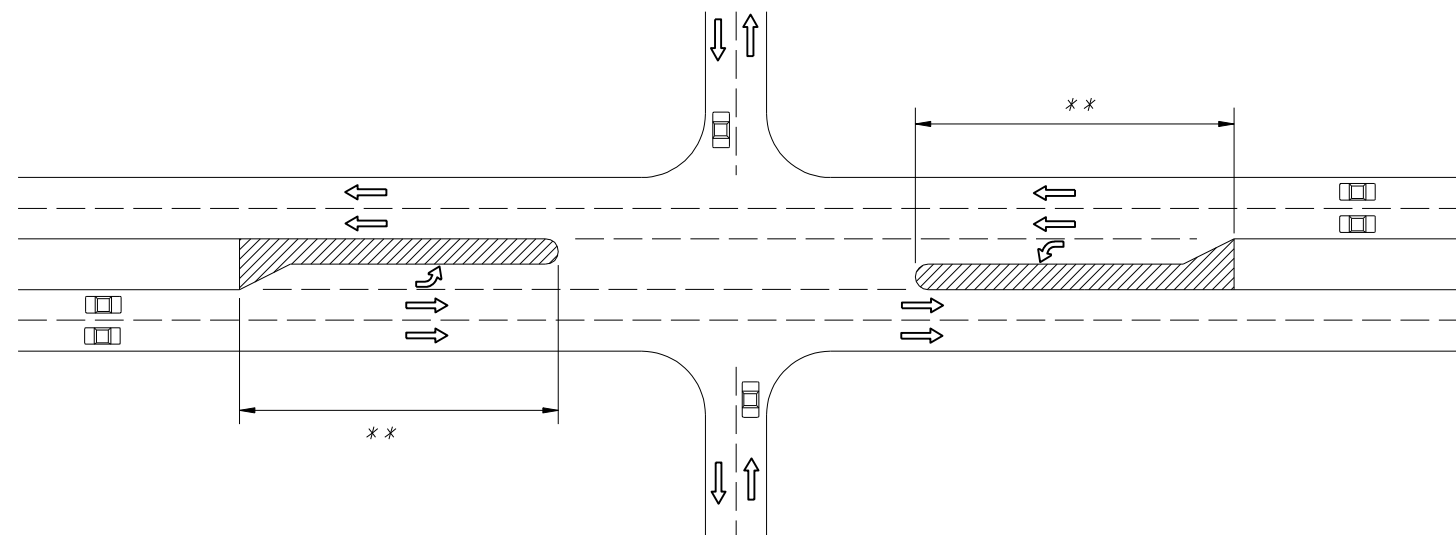

PLAN

Special Areas Limited to Ground Cover

** For Signalized and unsignalized intersections, the median area along left turn lanes, including the taper, shall be limited to ground cover with height not greater than 18" below the sight line datum regardless of whether or not the area is within the limit of clear sight.

REVISIONS

DATE	BY	DESCRIPTION	DATE	BY	DESCRIPTION
12/10/08	ABK	Added median treatment detail.			

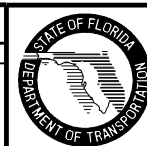

2008 Interim Design Standard

SIGHT DISTANCE AT INTERSECTIONS

Interim Date	Sheet No.
01/01/09	1 of 6
Index No.	
546	

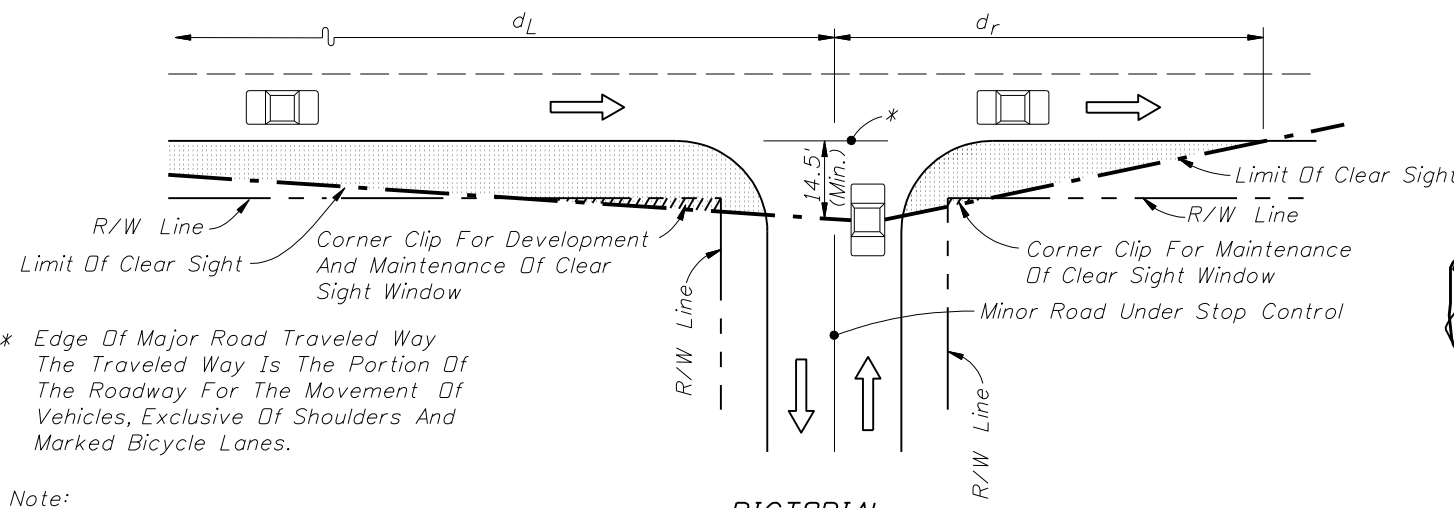

Note:
Lines For 'Limit Of Clear Sight' Are Opposite Hand When Major Road Near Lane Traffic Moving Left (e.g., One-Way Left).

PICTORIAL
ORIGIN OF CLEAR SIGHT LINE
ON MINOR ROAD

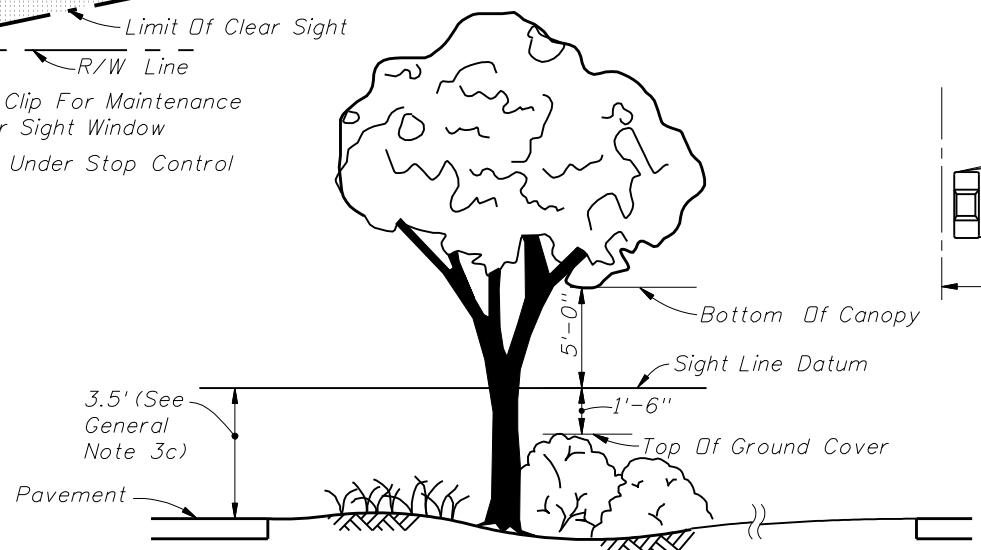

The Intent Of This Standard Is To Provide A Window With Vertical Limits Of Not Less Than 5' Above And 1'-6" Below The Sight Line Datum, And Horizontal Limits Defined By The Limits Of Clear Sight.

PICTORIAL
WINDOW DETAIL

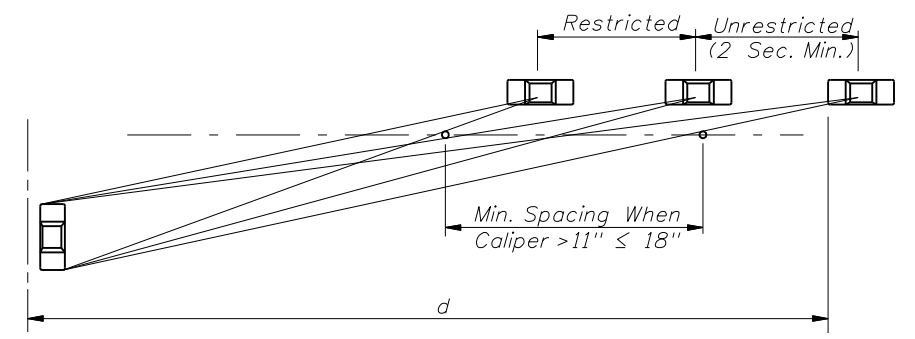

PERCEPTION DIAGRAM
SETTING SABAL PALM (STATE TREE) SPACING

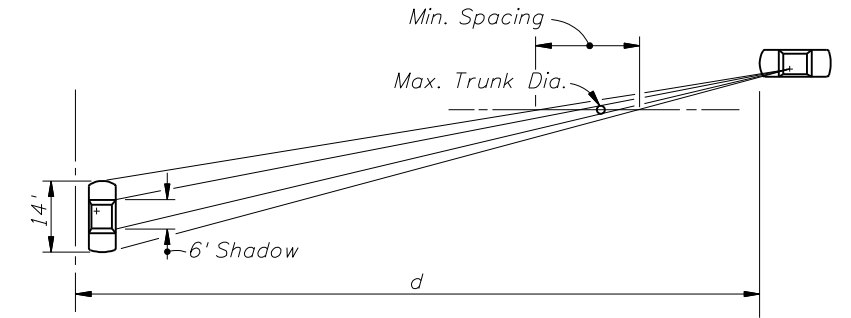

SHADOW DIAGRAM

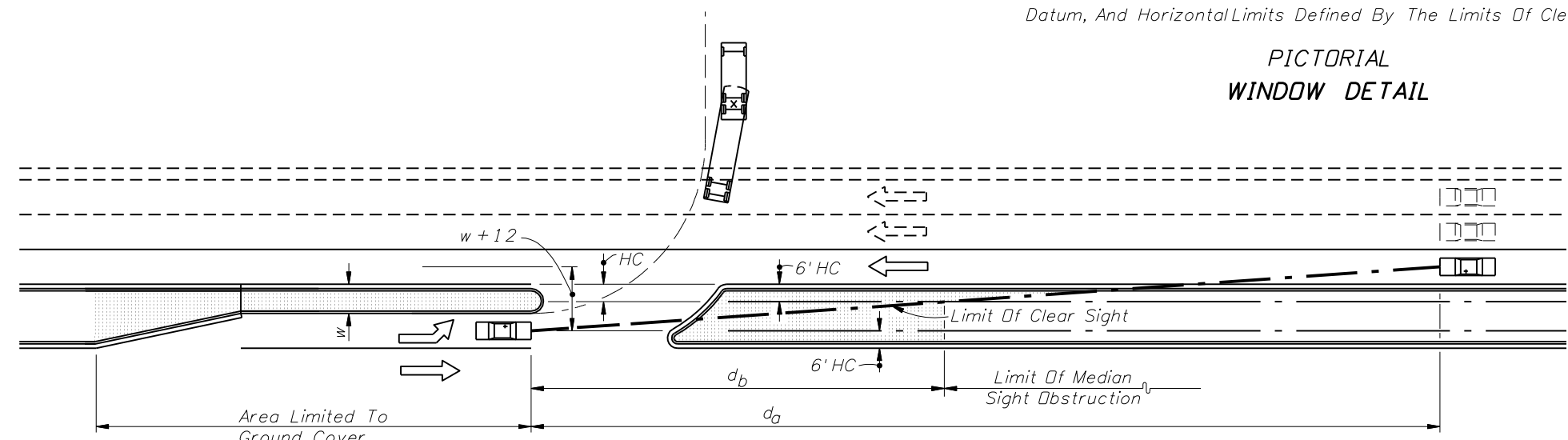

PICTORIAL

LEGEND

Areas Free Of Sight Obstructions

Design Speed MPH	d_0 (Feet)								
	1 Lane Crossed			2 Lanes Crossed			3 Lanes Crossed		
	P	SU	Comb.	P	SU	Comb.	P	SU	Comb.
30	245	285	330	265	320	360	285	350	390
35	285	335	385	310	370	420	335	405	460
40	325	380	440	355	425	480	380	465	525
45	365	430	495	395	475	540	430	520	590

☆ See Note.

☆ The d_0 values in this table were established by the method referenced in Design Note 2, and are applicable to urban, predominantly curbed roadways with design speeds of 45 mph or less and meeting the restricted conditions defined in Index No. 700. For horizontal clearance (HC) of six feet (6'), the values for d_b may be determined by the equation $d_b = d_0(w/(w+12))$. For roadways with nonrestricted conditions, d_0 and d_b should be based on the geometry for the left turn storage and on clear zone widths (See Index No. 700).

For wide medians where the turning vehicle can approach the through lanes at or near 90°, use d_v values from tables on sheets 4 or 5. (The clear sight line origin is assumed to be 14.5' from the edge of the near lane.)

CHANNELIZED DIRECTIONAL MEDIAN OPENINGS

REVISIONS

DATE	BY	DESCRIPTION	DATE	BY	DESCRIPTION
12/10/08	ABK	Added note for wide median sight distances.			

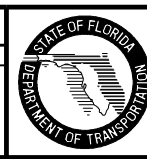

2008 Interim Design Standard

SIGHT DISTANCE AT INTERSECTIONS

Interim Date: 01/01/09
Sheet No.: 6 of 6
Index No.: 546