

PRECAST COLLAR IN AUGER CAST PILE

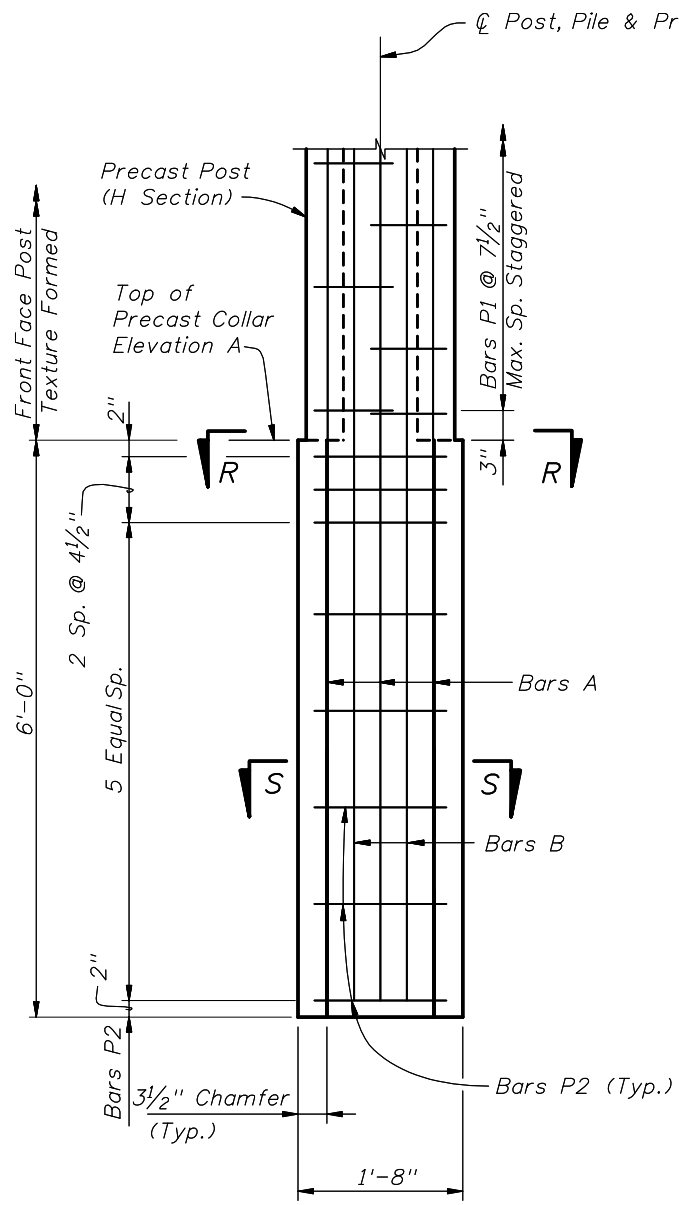

PRECAST COLLAR DETAIL

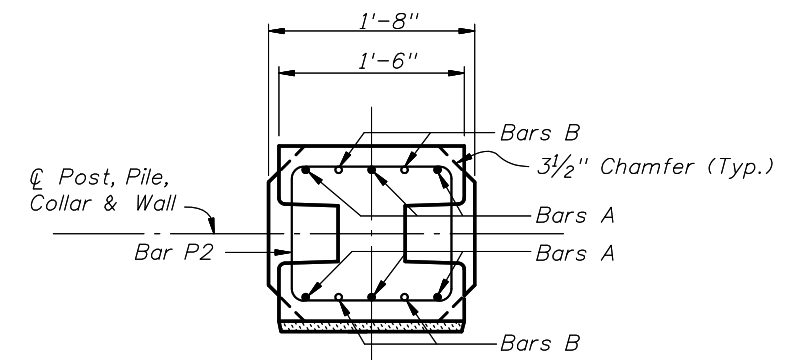

SECTION R-R

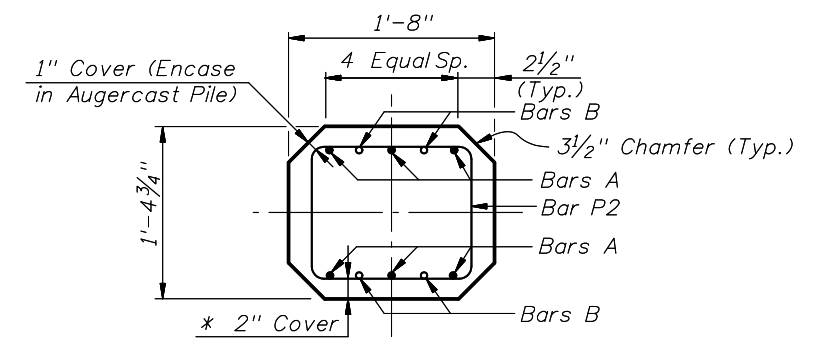

SECTION S-S

* - Unless Otherwise Noted.

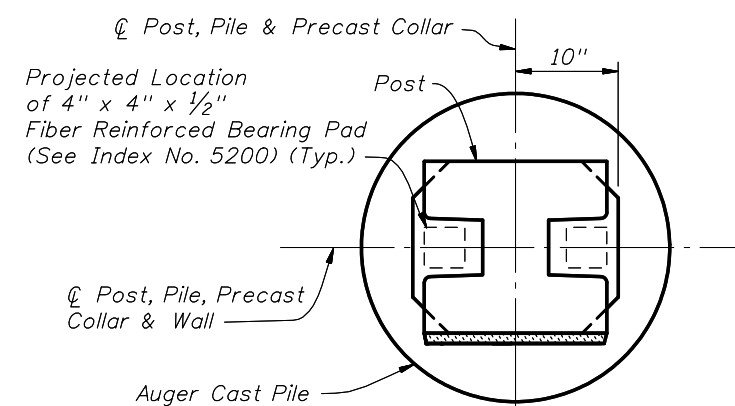

SECTION T-T

NOTES:

1. For Post and Pile Lengths, see Index No. 5206.
2. For Reinforcing Steel Sizes, see Index No. 5206.
3. For Pile/Post Connection Option A, see Sheet No. 1 of 7.

PRECAST COLLAR FOR PILE/POST CONNECTION OPTION A

REVISIONS			
DATE	BY	DESCRIPTION	DATE
07/01/08	SJN	Changed "Composite" to "Fiber Reinforced" in Section T-T. Added Tolerance for distance between Top of Precast Collar and Auger Cast Pile.	

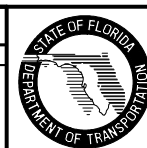

2008 Interim Design Standard

PRECAST SOUND BARRIERS -
PILE AND POST REINFORCING STEEL

Interim Date	Sheet No.
07/01/08	2 of 7
Index No.	
5205	

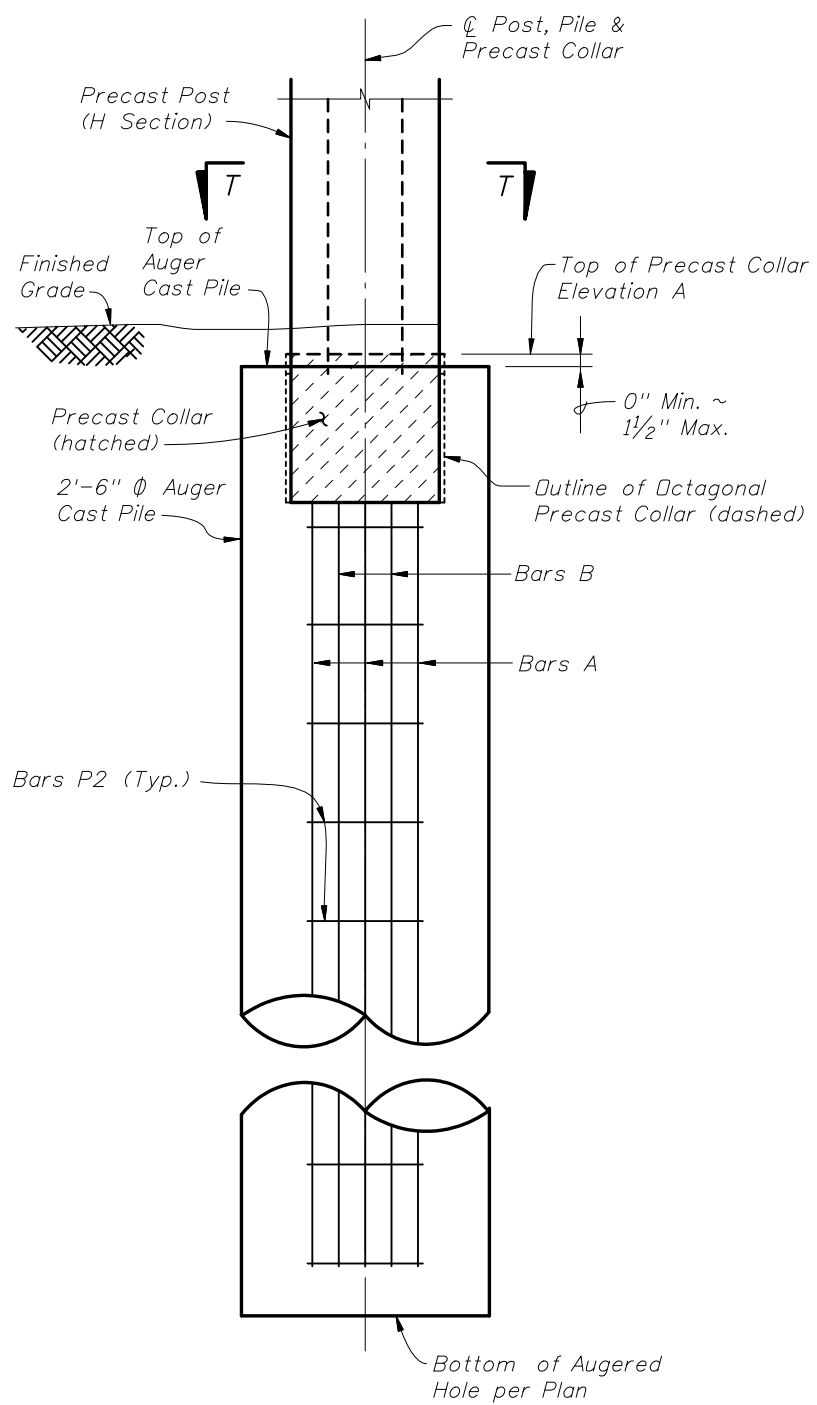

PRECAST COLLAR IN AUGER CAST PILE

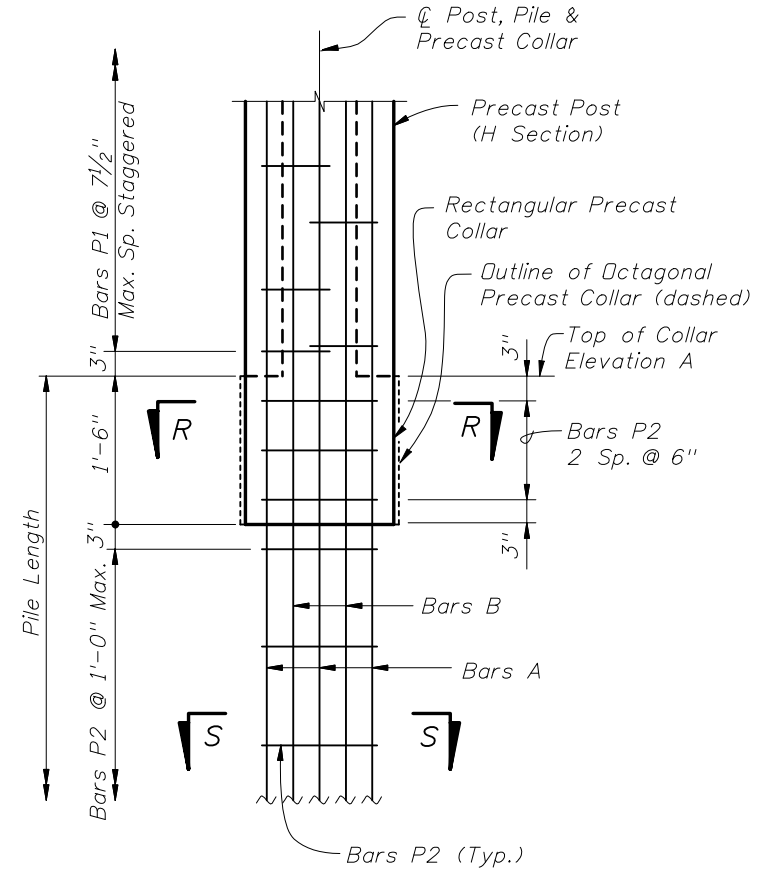

PRECAST COLLAR DETAIL

- NOTES:
1. For Post and Pile Lengths, see Index No. 5206.
 2. For Reinforcing Steel Sizes, see Index No. 5206.
 3. For Pile/Post Connection Option E, see Sheet No. 6 of 7.

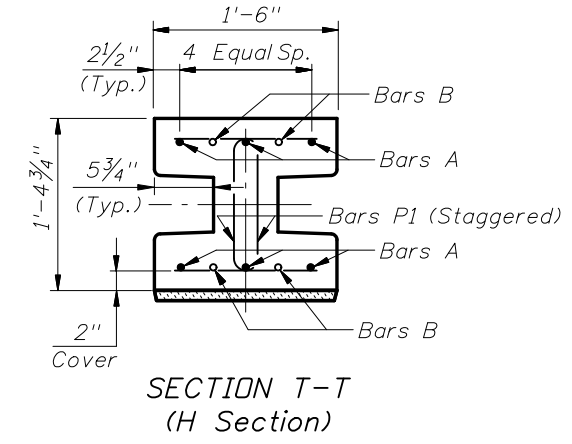

SECTION T-T (H Section)

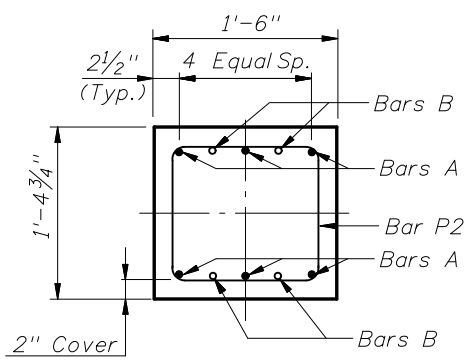

SECTION R-R (Rectangular Precast Collar)

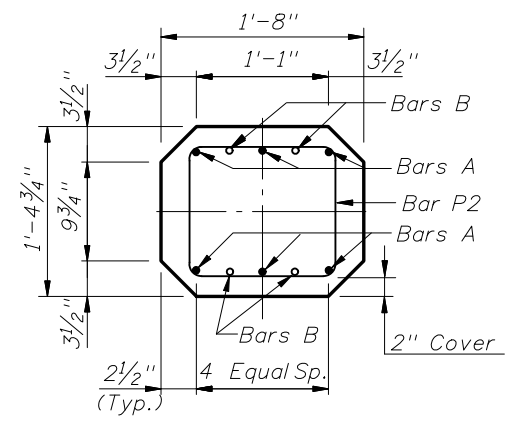

SECTION R-R (Octagonal Precast Collar)

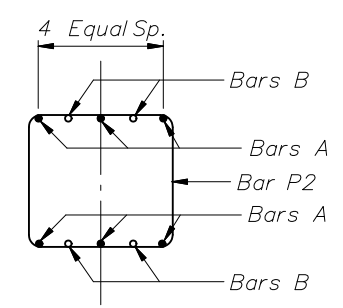

SECTION S-S

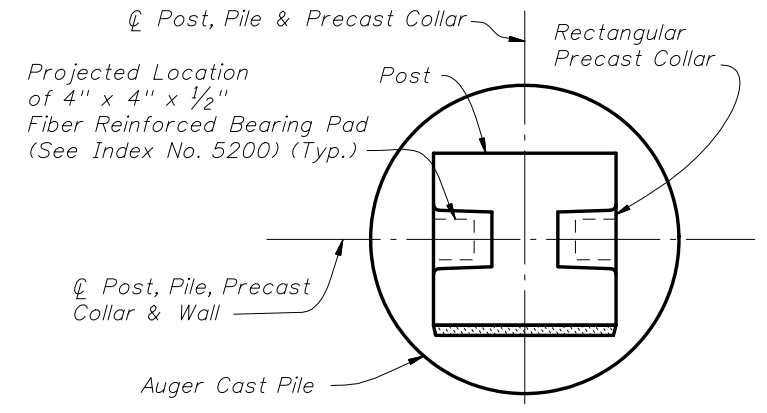

SECTION T-T (Showing Rectangular Precast Collar and Auger Cast Pile)

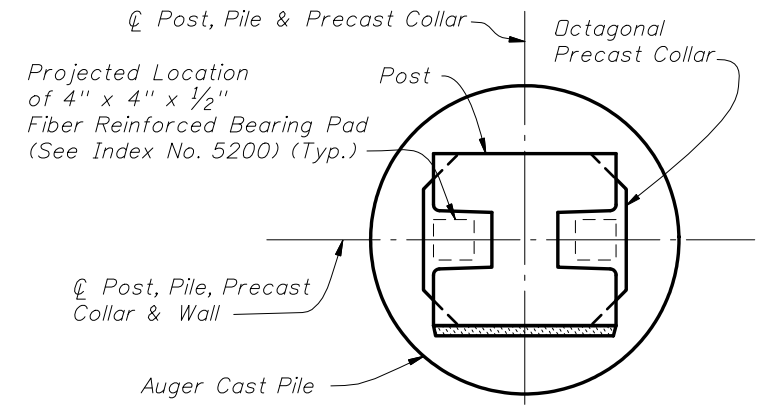

SECTION T-T (Showing Octagonal Precast Collar and Auger Cast Pile)

KEITH and SCHNARS, P.A.
ENGINEERS - PLANNERS - SURVEYORS
6500 NORTH ANDREWS AVENUE
FORT LAUDERDALE, FL 33309-2132
CERTIFICATE OF AUTHORIZATION NO. 1337

State Contracting & Engineering Corp.

STATE CONTRACTING & ENGINEERING CORP.
PRECAST COLLAR FOR PILE/POST CONNECTION OPTION E

REVISIONS			
DATE	BY	DESCRIPTION	
07/01/08	SJN	Added "Octagonal Precast Collar" details and tolerance between Top of Precast Collar and Auger Cast Pile. Changed section and details to accommodate Octagonal Precast Collar; "Composite" to "Fiber Reinforced" in Section T-T.	

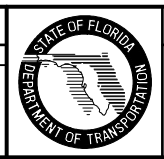

2008 Interim Design Standard
PRECAST SOUND BARRIERS - PILE AND POST REINFORCING STEEL

Interim Date: 07/01/08
Sheet No.: 7 of 7
Index No.: **5205**