

SPECIAL POSTS FOR 90° CORNERS FOR PILE/POST CONNECTION OPTIONS A, B & E
Collars for Special Posts shall be 3'-6" Ø

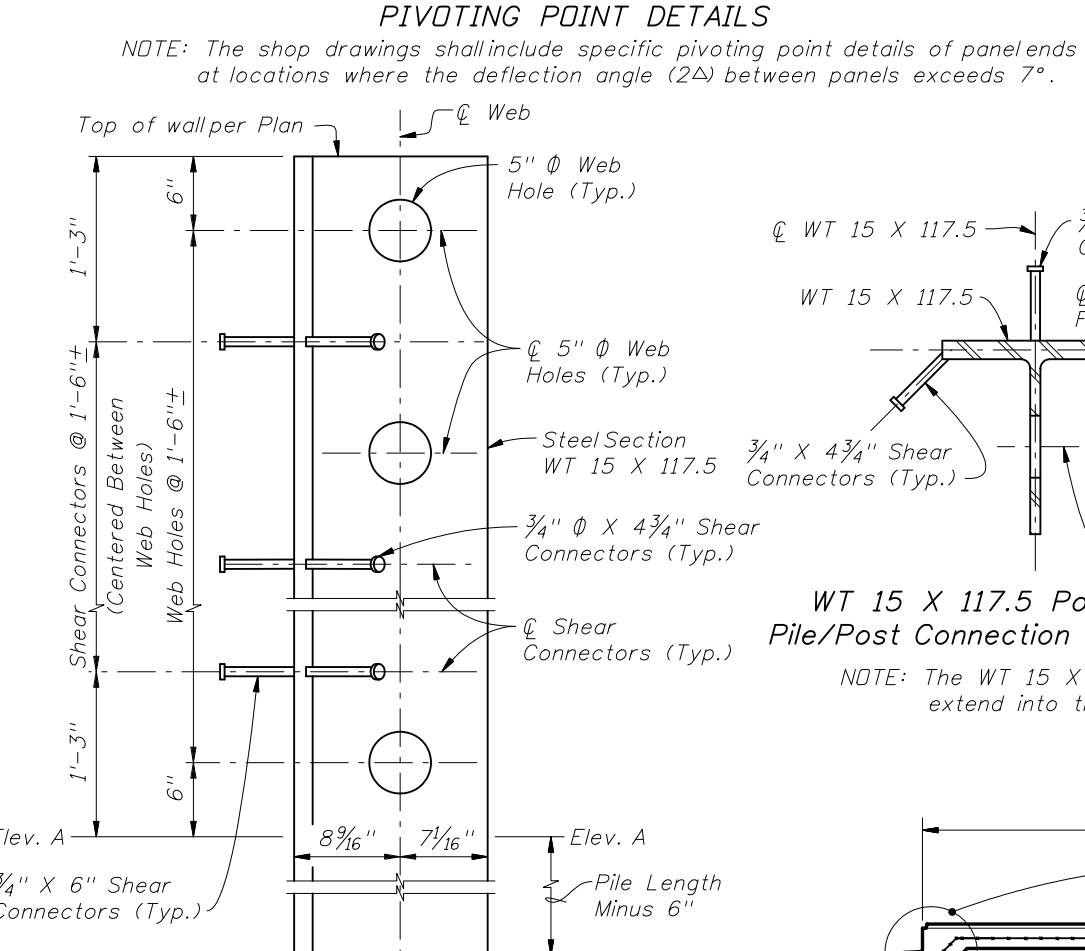

WEB HOLE & SHEAR CONNECTOR SPACING DETAIL
(Concrete not shown for clarity. For limits of concrete see Index No. 5205, Sheet No. 4 of 7.)

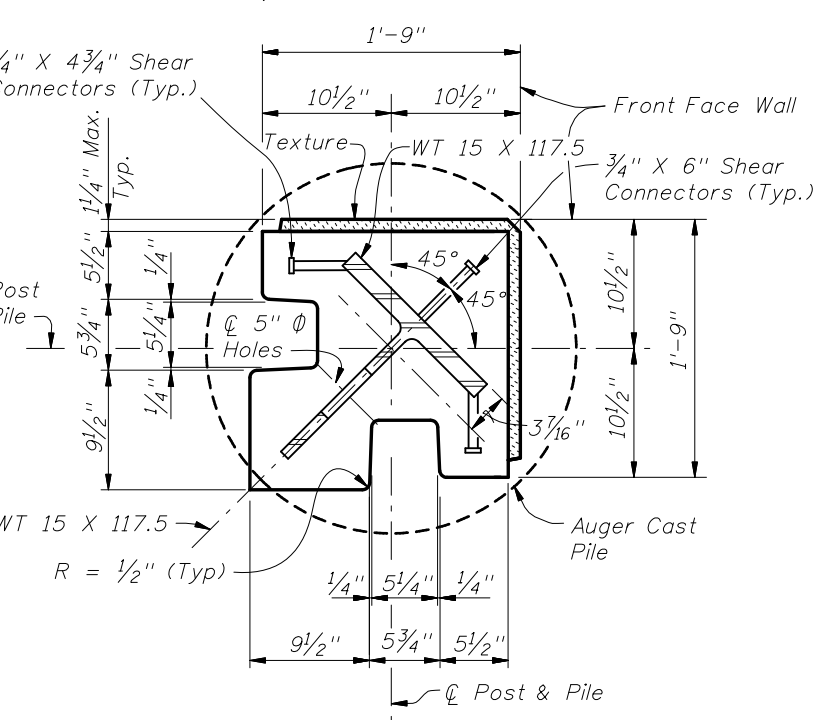
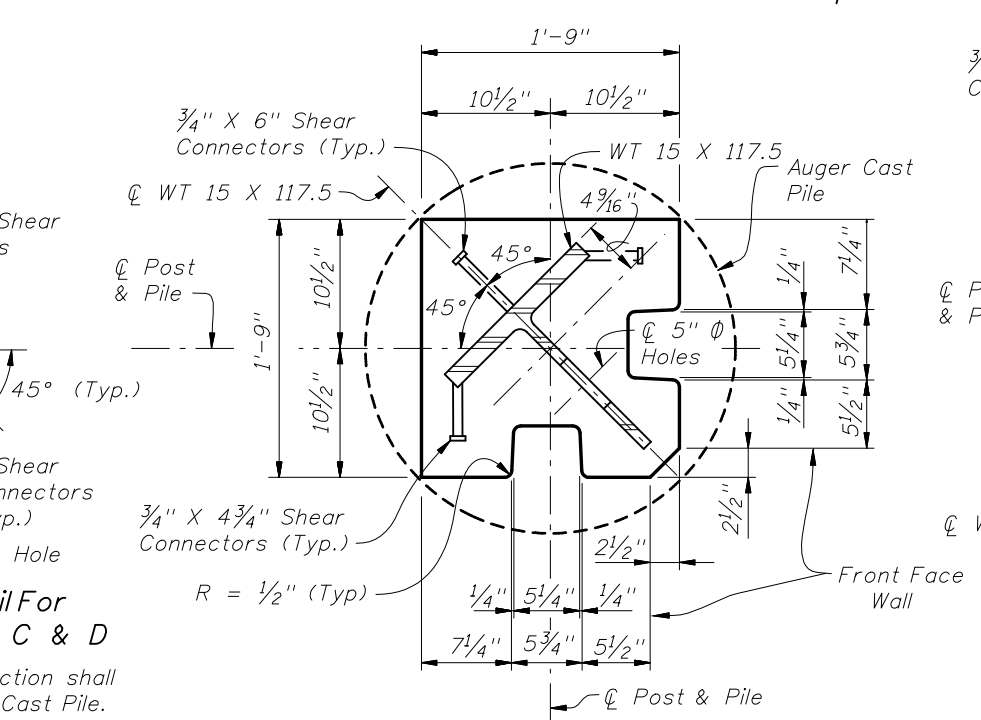

SPECIAL POSTS FOR 90° CORNERS FOR PILE/POST CONNECTION OPTIONS C & D
Collars for Special Posts shall be 3'-6" Ø

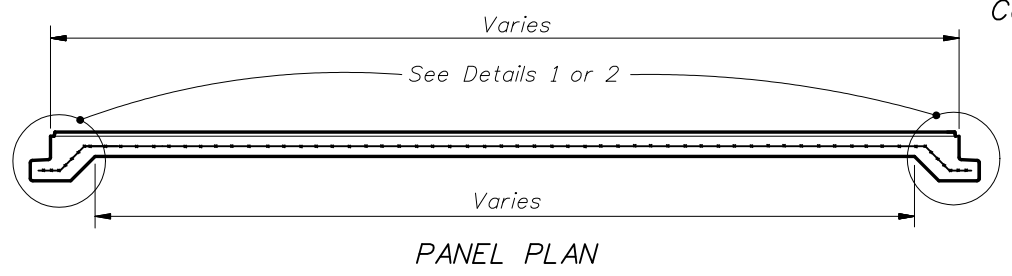

- NOTES:
1. For Table of Reinforcing Steel Sizes, see Index No. 5206.
2. For Pile/Post Connection Options A through E, see Index No. 5205.
3. For Post & Pile Lengths, see Index No. 5206.

REVISIONS			
DATE	BY	DESCRIPTION	
01/01/09	SJN	Changed #4 Bar Mark to Bars P5 and P6 for Pile/Post Options A, B, & E ; Texture Thickness to 1/4" Max.	

2008 Interim Design Standard

**PRECAST SOUND BARRIERS
- FLUSH PANEL OPTION**

Interim Date: 01/01/09
Sheet No. 3 of 4
Index No. **5202**