

**Wall joint spacing 25 ft. maximum.
At minimum, every fourth wall joint to be an expansion joint.
See Plans for actual wall joint spacing and expansion joint location.

All exposed wall surfaces shall receive a Class 5 Applied Finish Coating

Ground Line
Top of Footing Level (typ.)

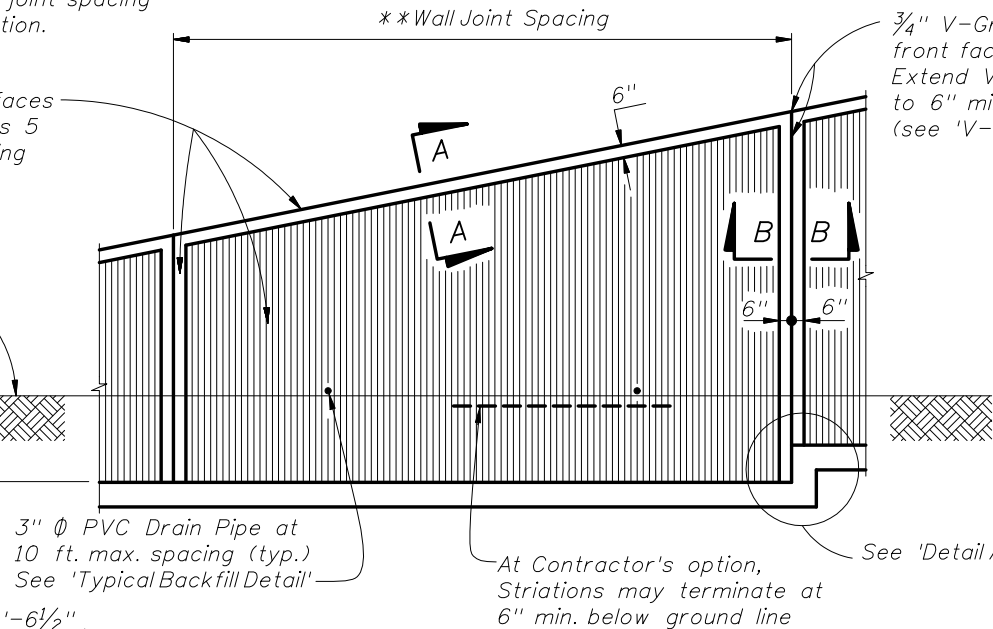

FRONT ELEVATION

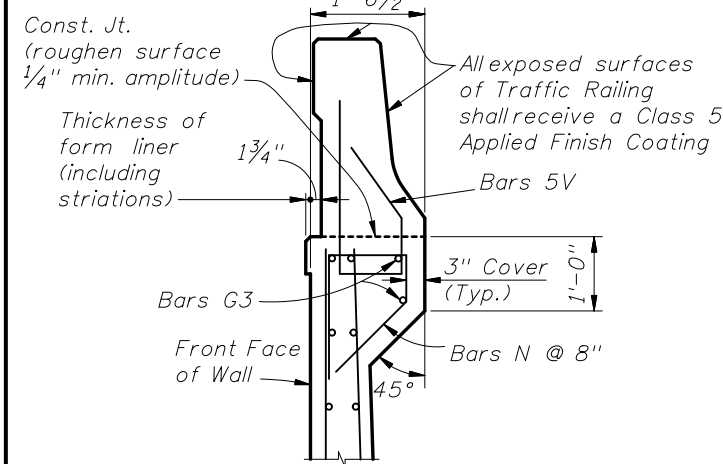

TRAFFIC RAILING ON WALL DETAIL
(for Traffic Railing details see Index No. 420)

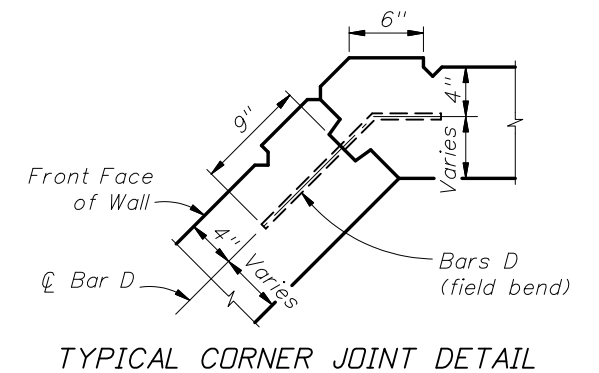
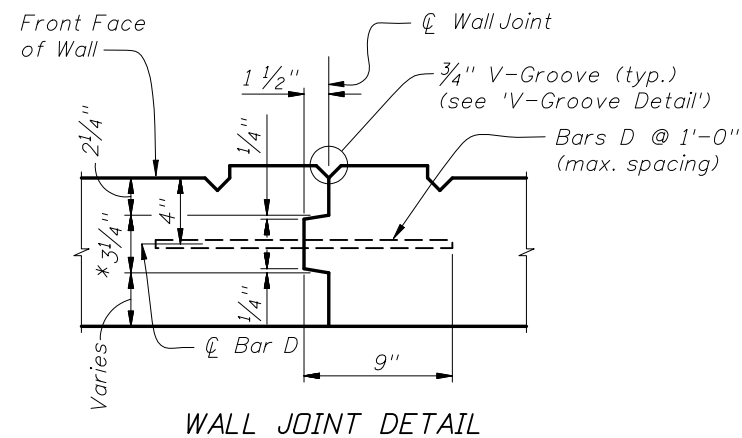
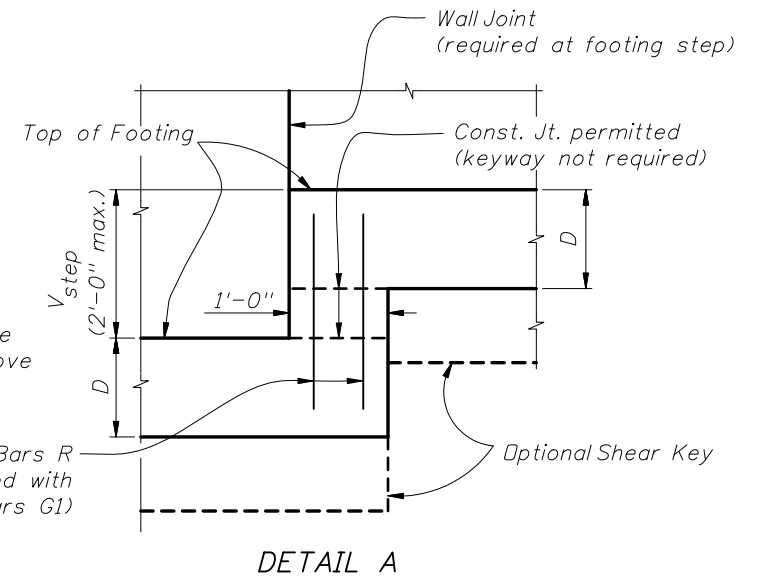
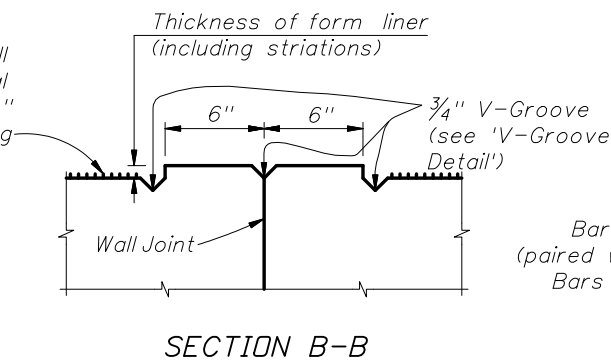
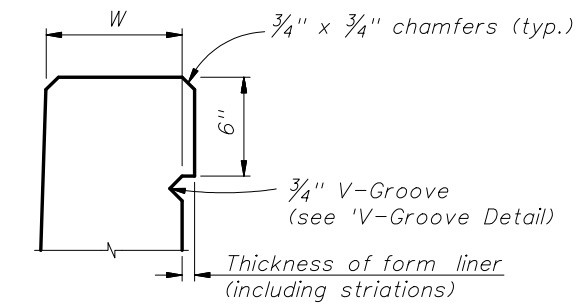
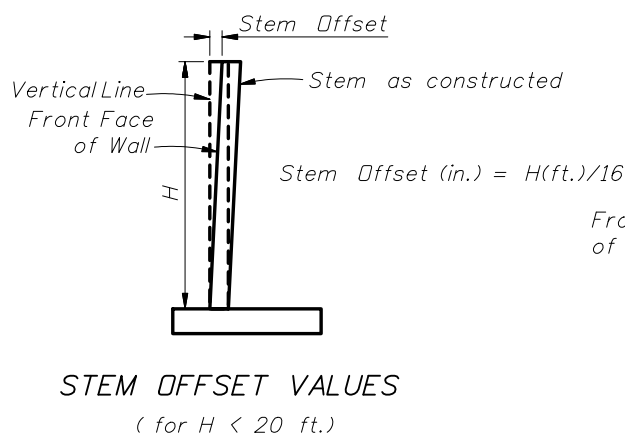
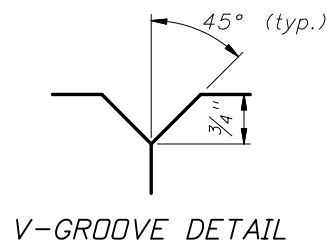

*Key to stop at top of footing and 6" from top of wall. Joint across footing and top of wall to be straight line.

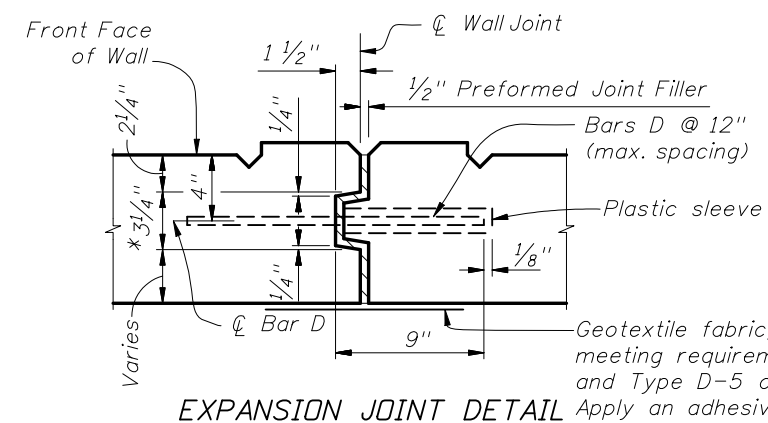

Geotextile fabric, 1'-0" wide and full height of fill, meeting requirements of FDOT Specification 985 and Type D-5 of Index No. 199. Apply an adhesive approved by the Engineer to the back of wall for attachment of fabric material.

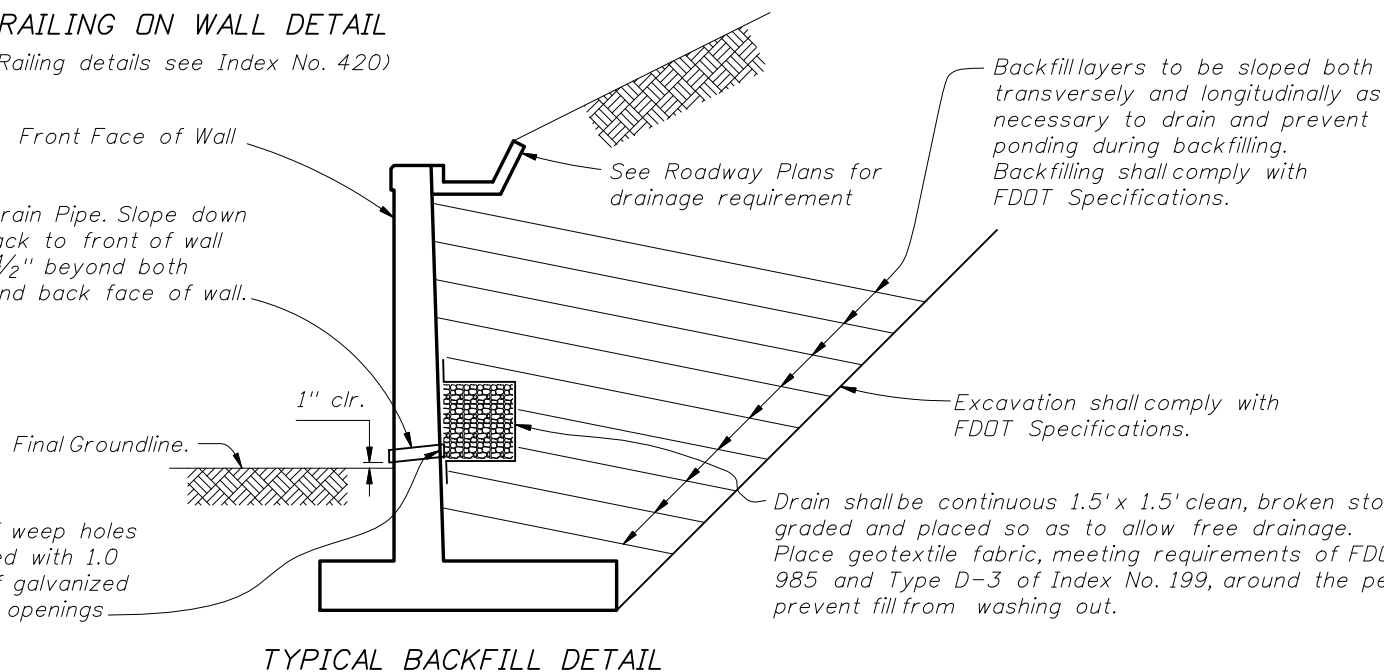

REVISIONS

DATE	BY	DESCRIPTION	DATE	BY	DESCRIPTION
07/01/08	CBH	Changed to plastic sleeve expansion joint.			
01/01/09	CBH	Changed Wall Joint and Expansion Joint Key.			

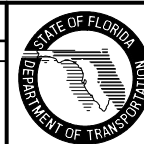

2008 Interim Design Standard

RETAINING WALL - CAST IN PLACE

Interim Date	Sheet No.
01/01/09	2 of 2
Index No.	
5100	