

PLAN

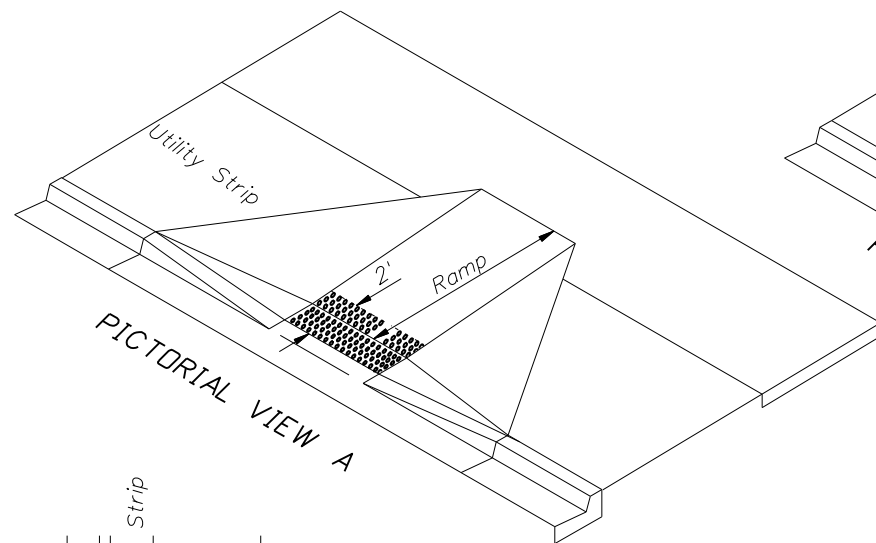

PICTORIAL VIEW A

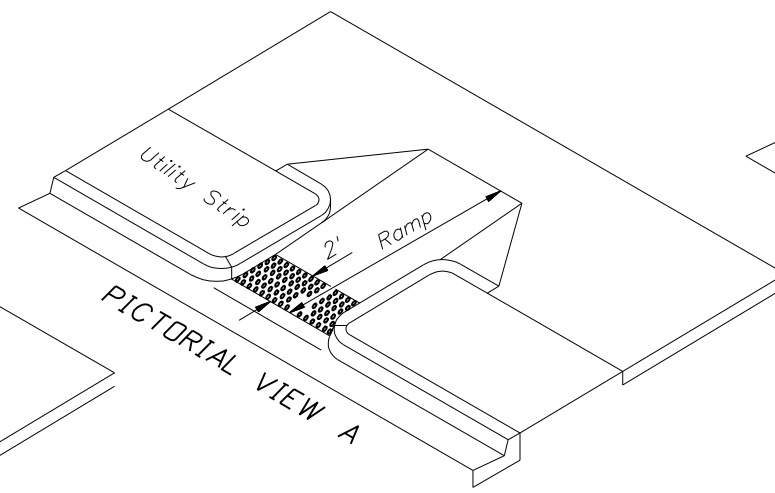

PICTORIAL VIEW A

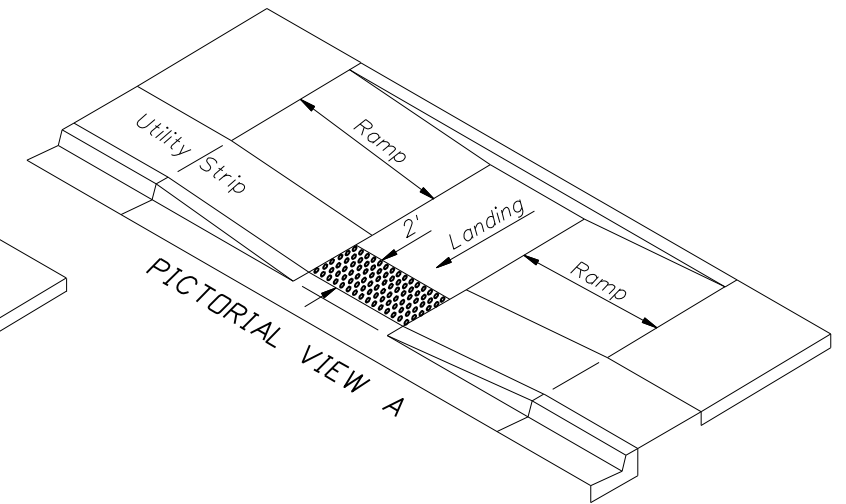

PICTORIAL VIEW A

On curb ramps, landings and flush transitions perpendicular to the curb line: Rows of domes shall be aligned with the centerline of the ramp. (See Pictorial View A)

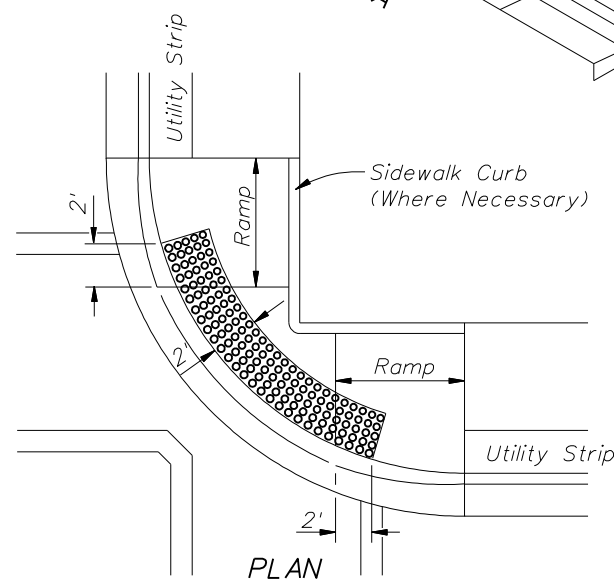

PLAN

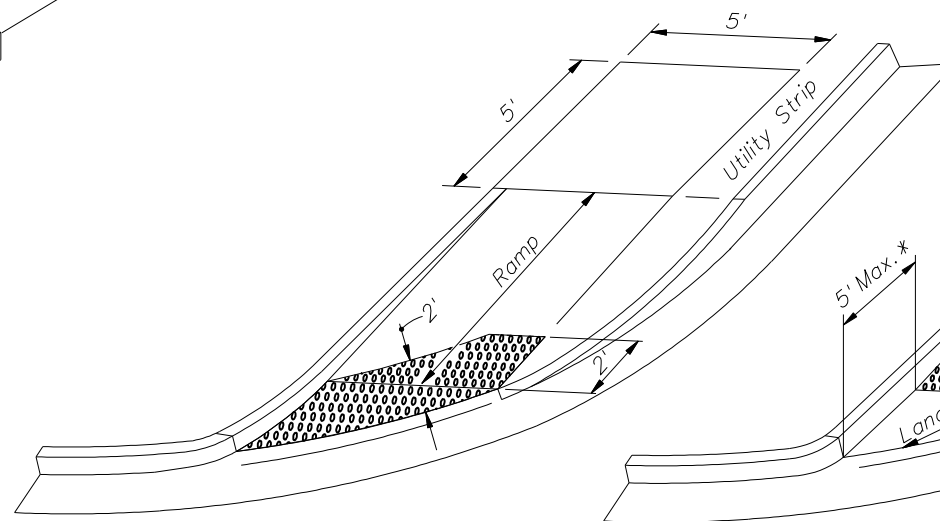

PICTORIAL VIEW B

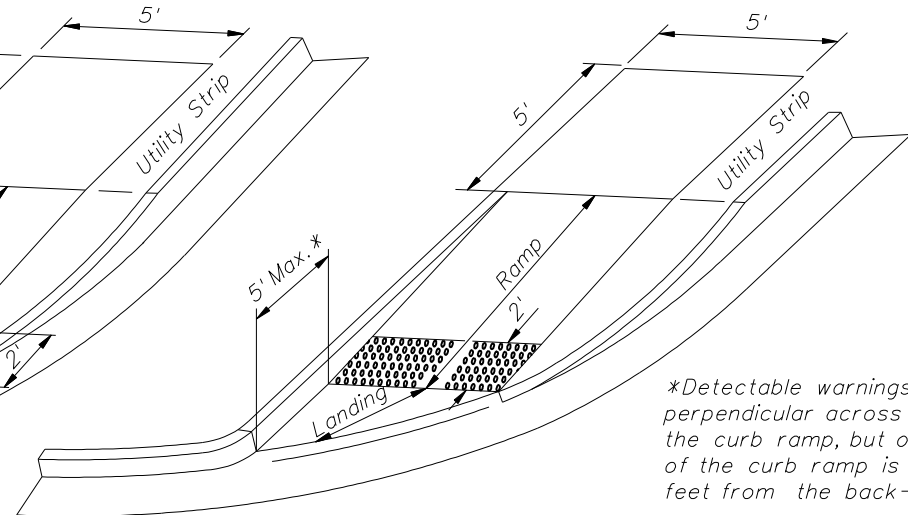

PICTORIAL VIEW C

\*Detectable warnings may be placed perpendicular across the bottom of the curb ramp, but only if the bottom of the curb ramp is no more than 5 feet from the back-of-curb.

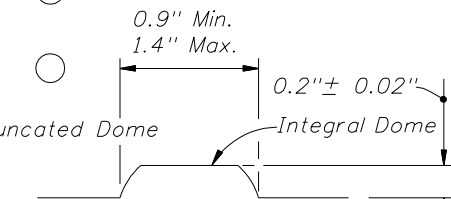
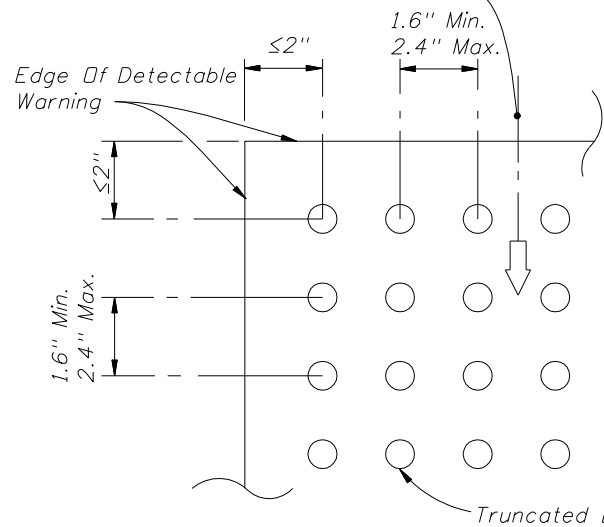

The top width of the dome shall be a minimum of 50% and a maximum of 65% of the base diameter.

TRUNCATED DOME

Base-to-base spacing shall be 0.65" minimum between domes.

PLAN VIEW

Detectable warnings shall extend 24 inches deep, perpendicular to the back-of-curb. Detectable warnings shall be no more than 2 inches from the back-of-curb/expansion joint.

DETECTABLE WARNING DETAIL

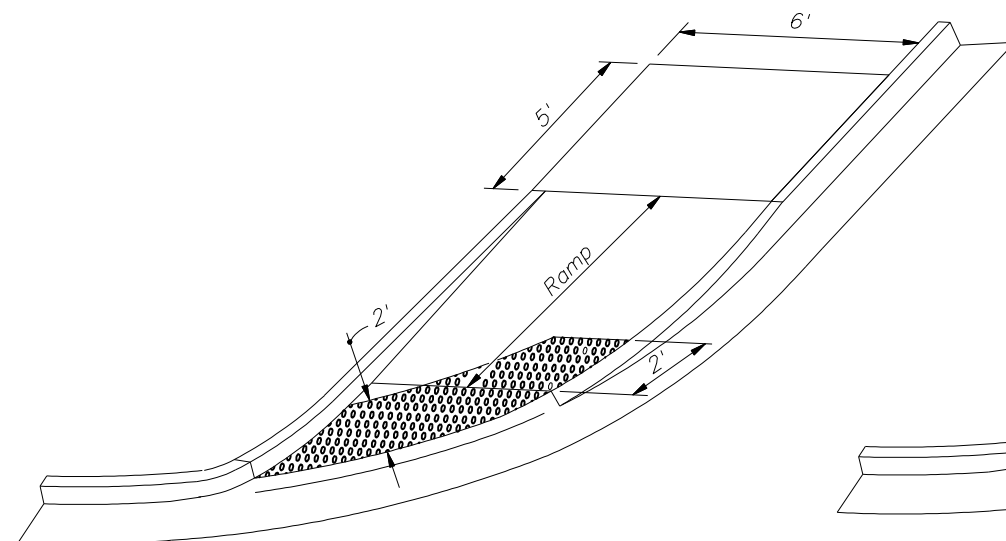

PICTORIAL VIEW B

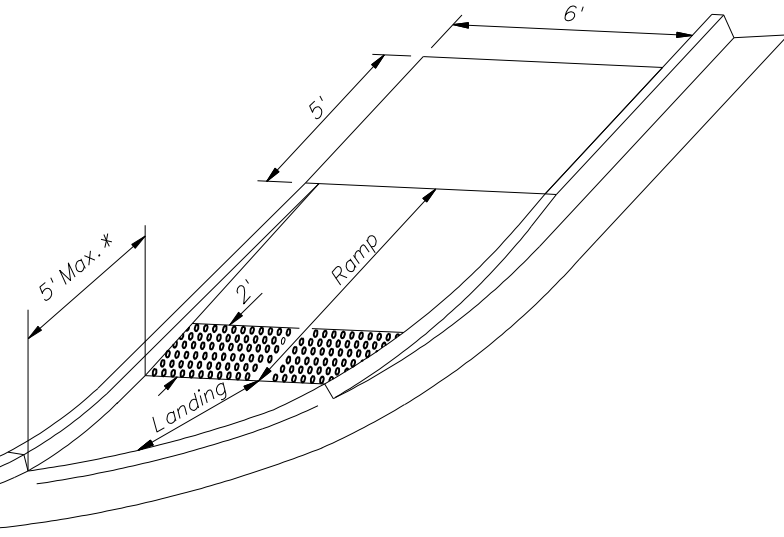

PICTORIAL VIEW C

On landings and flush transitions at radius returns: Rows of domes are not required to be aligned with the centerline of the ramp. (See Pictorial View B)

On curb ramps at radius returns: Rows of domes shall be aligned with the centerline of the ramp. (See Pictorial View C)

TYPICAL PLACEMENT OF DETECTABLE WARNING AT CURB RAMPS

REVISIONS

DATE	BY	DESCRIPTION	DATE	BY	DESCRIPTION
03/03/08	HDP	Added alternate location on linear ramps.			

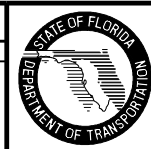

2008 Interim Design Standard

PUBLIC SIDEWALK CURB RAMPS

Interim Date	Sheet No.
04/30/08	6 of 6
Index No.	
304	