

SECTION C-C
C-I-P HEADWALL DETAILS AND CONNECTION TO PRECAST BOX

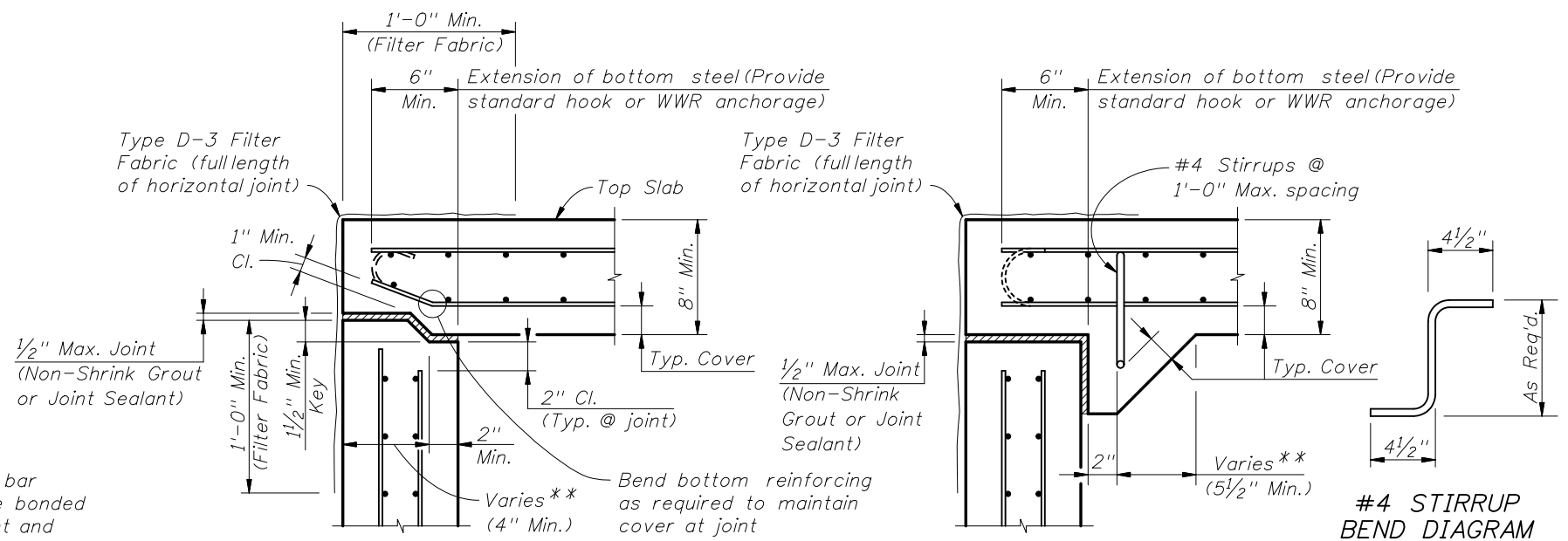

SECTION B-B
TOP SLAB TO WALL JOINT (KEYED JOINT)

SECTION B-B
TOP SLAB TO WALL JOINT (HAUNCHED JOINT)

** Provide adequate width to satisfy shear strength requirements at joint

TYPE B BOX LONGITUDINAL JOINTS

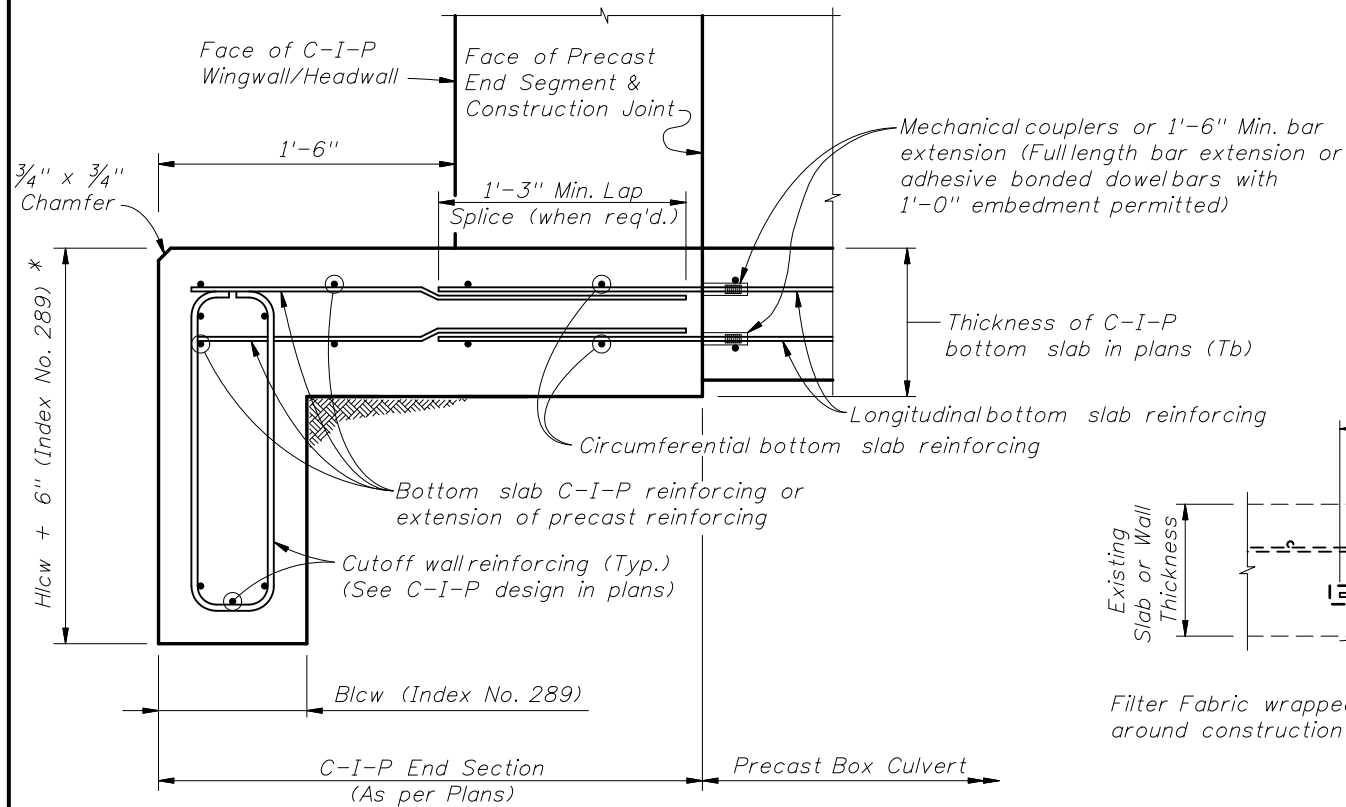

SECTION D-D
C-I-P TOE SLAB & CUTOFF WALL DETAILS AND CONNECTION TO PRECAST BOX

* Provide additional 6" depth of cutoff wall at no additional cost.

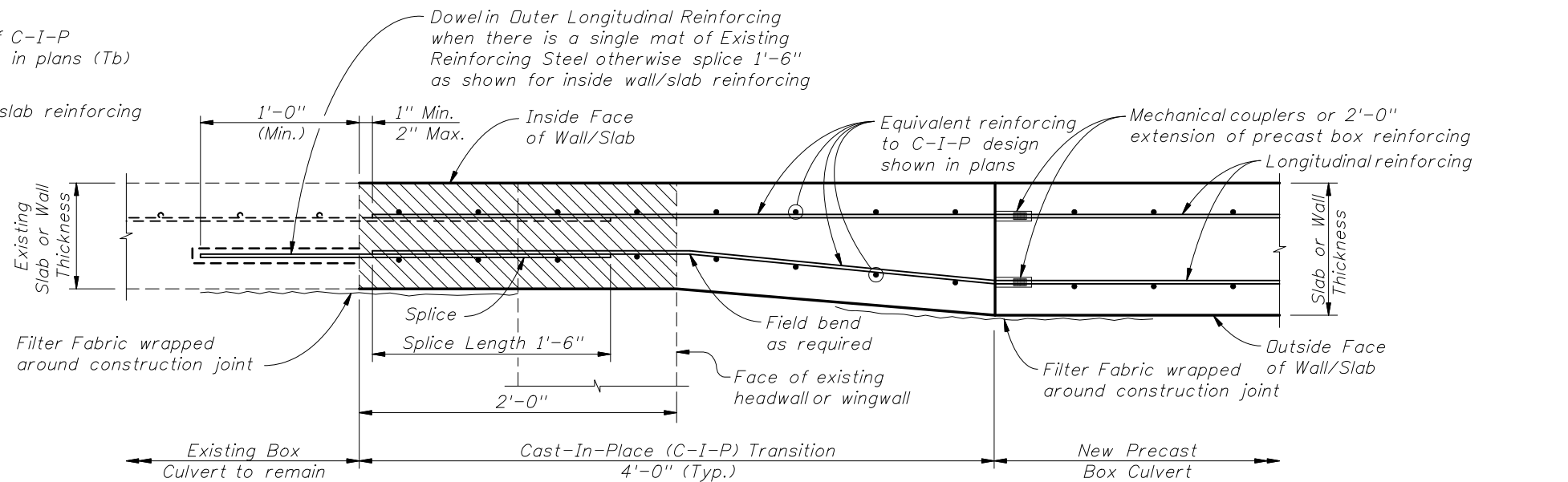

SECTION E-E
EXTERIOR WALL/SLAB TRANSITION DETAIL FOR PRECAST EXTENSION

▨ Section of Existing Box Culvert to be removed and replaced.

REVISIONS

DATE	BY	DESCRIPTION	DATE	BY	DESCRIPTION
07/01/09	SJN	Added "or Joint Sealant" to 1/2" Joint in Section B-B.			

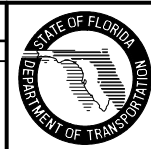

2008 Interim Design Standard

SUPPLEMENTAL DETAILS FOR PRECAST
CONCRETE BOX CULVERTS

Interim Date	Sheet No.
07/01/09	3 of 5
Index No.	
291	