

RECOMMENDED MAXIMUM PIPE SIZES	
INLET INSIDE WIDTH	PIPE SIZE
2'-11" or 3'-3"	24"
4'-0" or 3'-10"	30"

Note: Recommended sizes are for concrete pipe. Sizes for other types of pipe must be verified for fit in accordance with Index No. 201. For larger pipe see bottom detail below and Index No. 200.

HORIZONTAL WALL REINFORCING SCHEDULE (TABLE 1)				
WALL DEPTH	SCHEDULE	AREA (in ² /ft)	MAX. SPACING	
			BARS	WWF
0'-5'	A12	0.20	12"	8"
5'-9'	A6	0.20	6"	5"
9'-12'	A4	0.20	4"	3"
9'-15'	B5.5	0.24	5 1/2"	5"

PLAN (CAST-IN-PLACE INLET WITHOUT GRATE SHOWN, PRECAST INLET SIMILAR)

SECTION BB (CAST-IN-PLACE INLET SHOWN, PRECAST INLET SIMILAR)

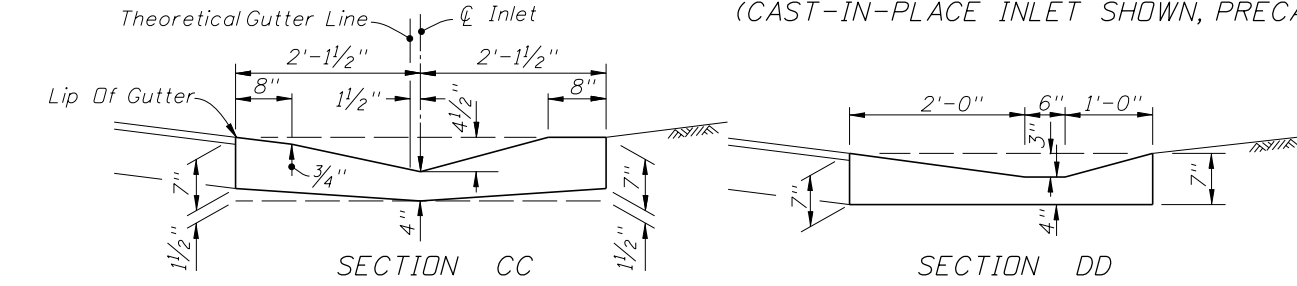

SECTION CC

SECTION DD

SHOULDER GUTTER TRANSITION

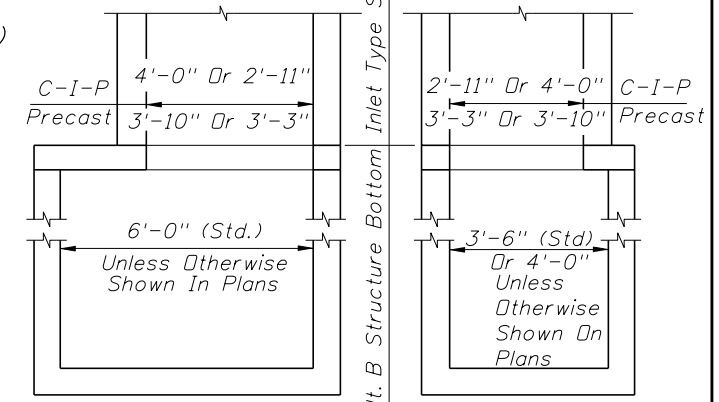
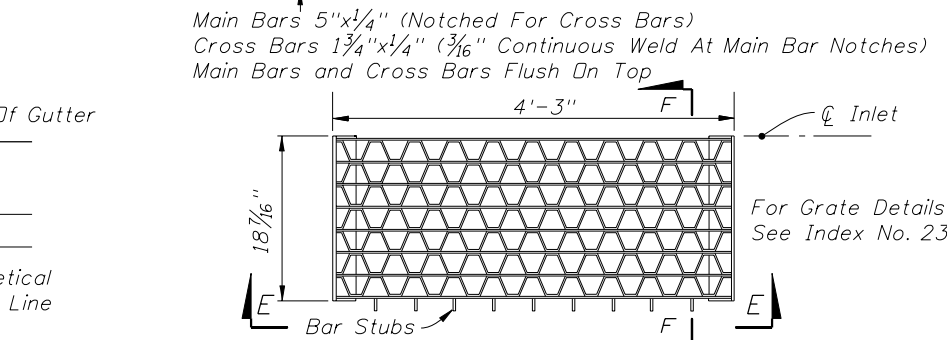
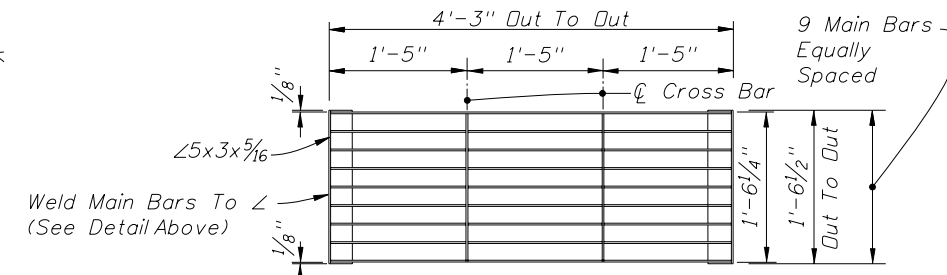
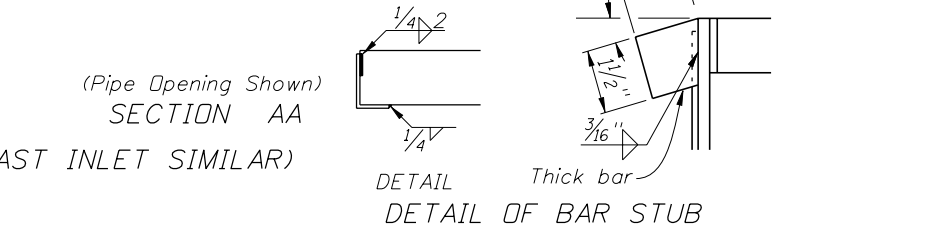

NOTE: Alt. B Structure Bottom Only. See Index No. 200 for structure bottom details and hole reinforcement.

- INLET WITH STRUCTURE BOTTOM
- GENERAL NOTES
- This inlet is intended for use in shoulder gutter on facilities subject to heavy wheelloads. The parallel bar grate shall be used on limited access facilities. On other facilities the reticuline grate shall be used. Locate inlet outside of designated pedestrian travel way.
 - All reinforcing is Grade 60 bars with 2" min. cover unless otherwise noted. See Index No. 201 for equivalent area of welded wire fabric. Bars to be cut or bent for 1/2" minimum clearance around pipe.
 - All exposed edges and corners shall be 3/4" chamfer or tooled to 1/4" radius.
 - When Alternate G grate is specified in plans, the grate is to be hot-dip galvanized after fabrication.
 - For supplementary details see Index Nos. 200 and 201.
 - All dimensions are for both precast and cast-in-place inlets unless otherwise noted.
 - Inlets to be paid for under the contract unit price for inlets (Gutter Type S), EA. Cost of concrete apron at terminal inlets to be included in the cost of the inlet.

REVISIONS			
DATE	BY	DESCRIPTION	
05/12/09	SUN	Clarify recess depth of top of inlet for steel grate.	