

PARTIAL PLAN VIEW OF SKEWED JOINTS

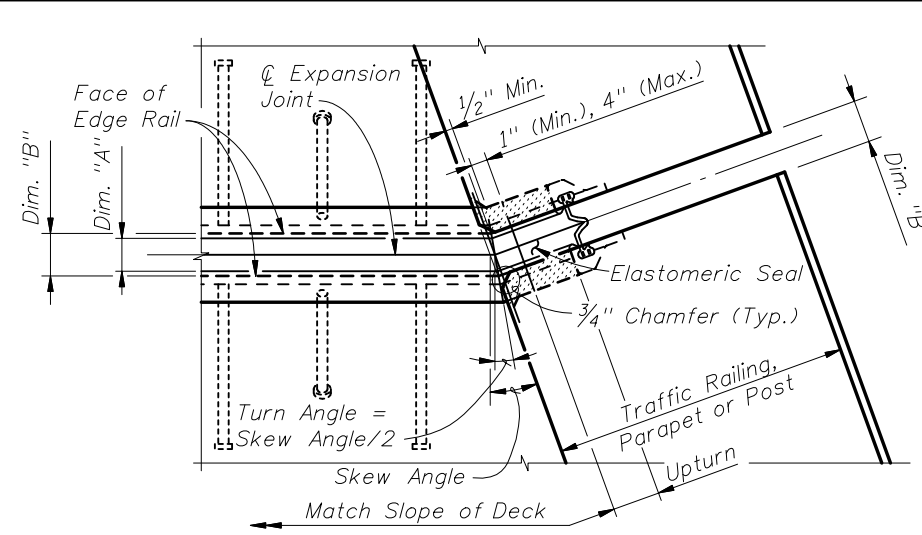

PARTIAL PLAN VIEW OF JOINTS SKEWED GREATER THAN 6°

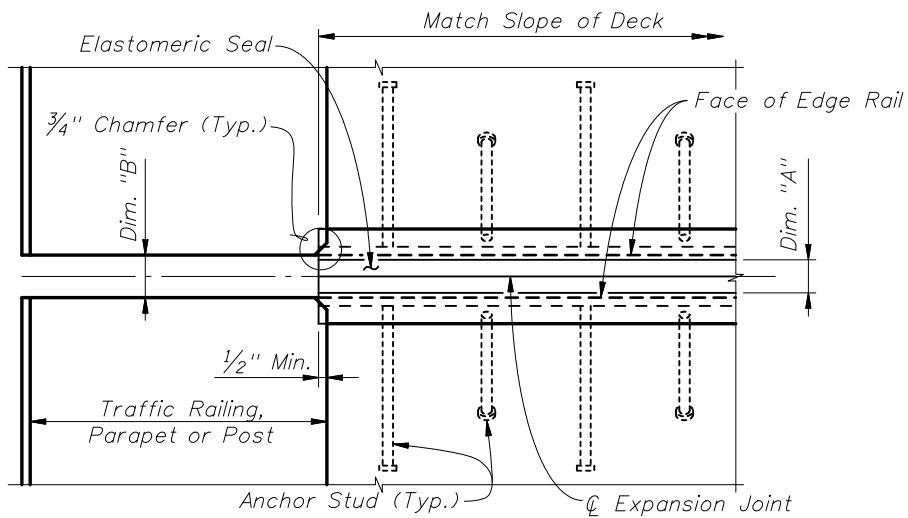

PARTIAL PLAN VIEW OF NONSKEWED JOINTS

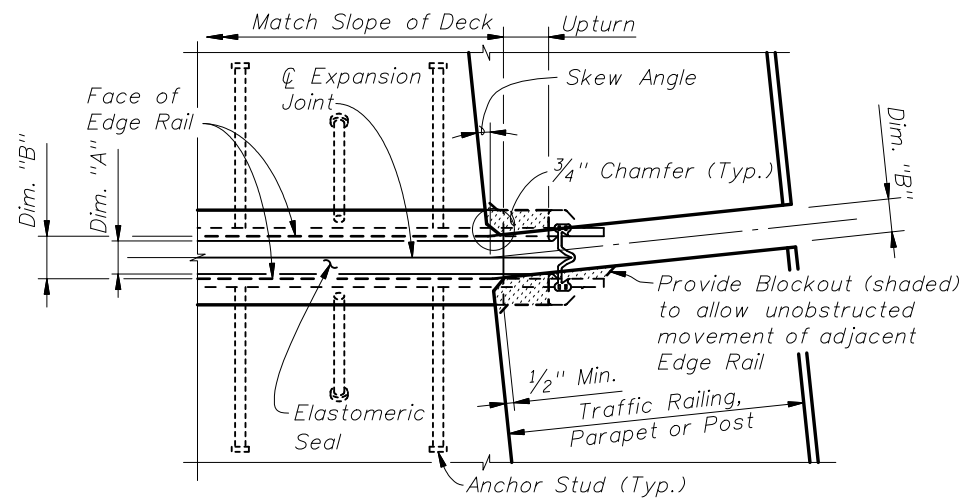

PARTIAL PLAN VIEW OF NONSKEWED JOINTS & JOINTS SKEWED 6° OR LESS

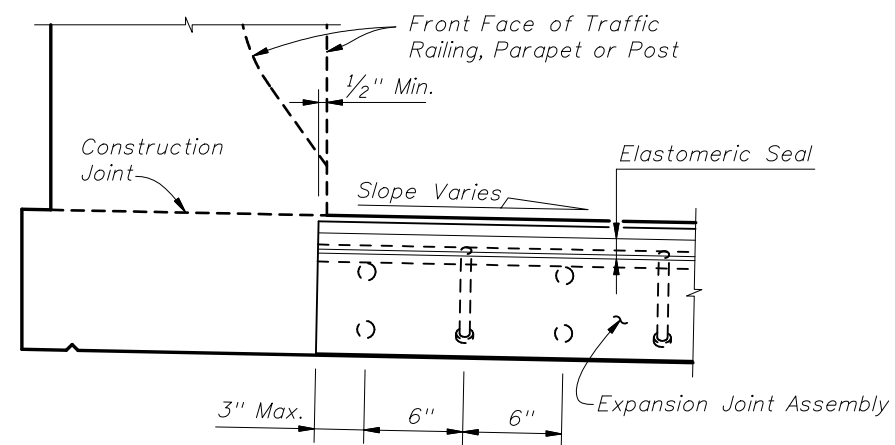

PARTIAL SECTION ALONG Q JOINT

JOINT TREATMENT AT HIGH SIDE OF DECK WITH SLOPE  $\geq 2\%$   
(Sidewalk Cover Plate where applicable not shown for clarity)

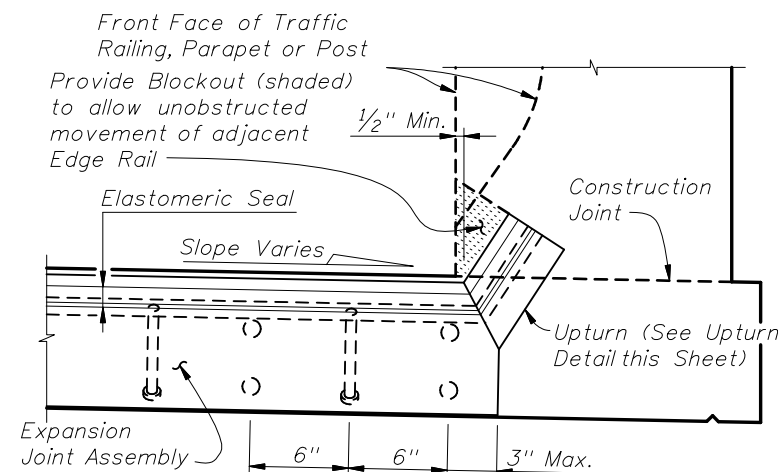

PARTIAL SECTION ALONG Q JOINT

JOINT TREATMENT AT LOW SIDE OF DECK & HIGH SIDE OF DECK WITH SLOPE  $< 2\%$   
(Sidewalk Cover Plate where applicable not shown for clarity)

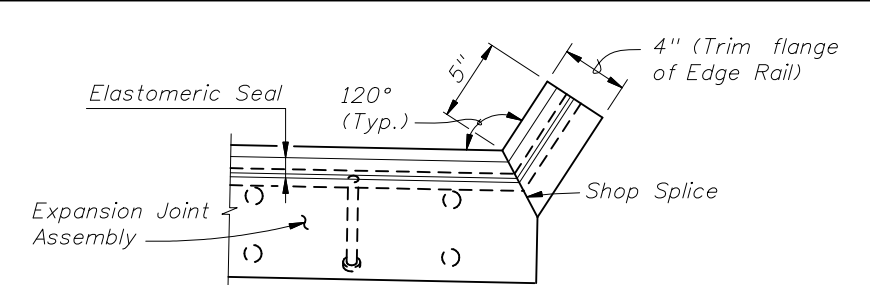

UPTURN DETAIL  
(TYPICAL AT TRAFFIC BARRIERS AND PARAPETS)

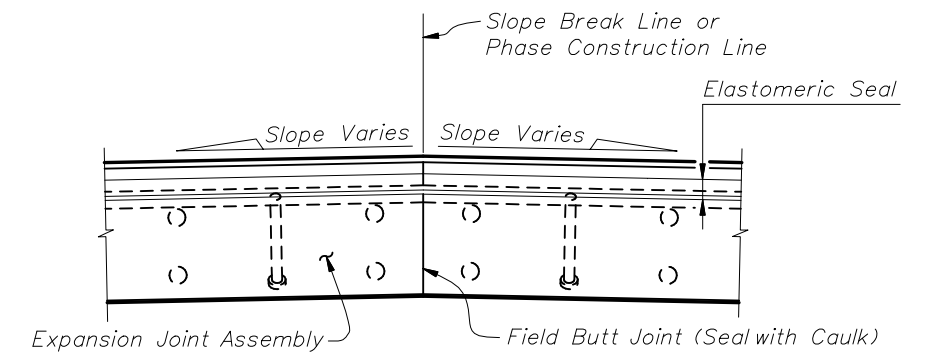

PARTIAL SECTION ALONG Q JOINT AT FIELD BUTT JOINT LOCATION  
(CROWNED DECK OR SLAB SHOWN)

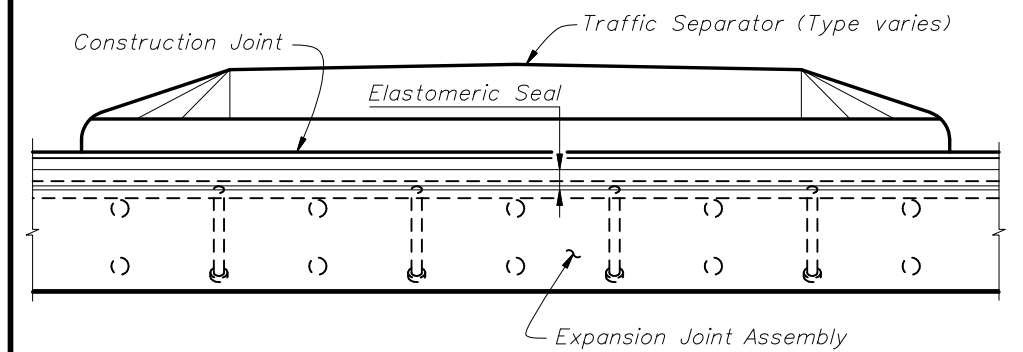

PARTIAL SECTION ALONG Q JOINT THRU TRAFFIC SEPARATOR

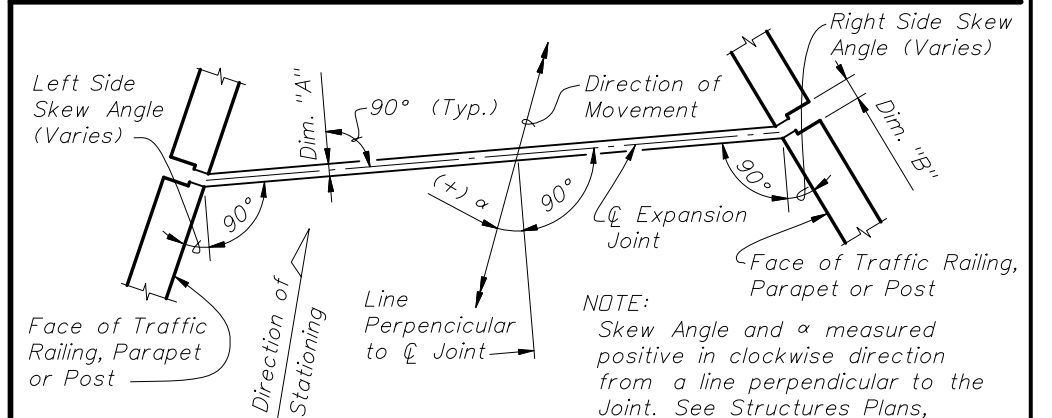

MOVEMENT SCHEMATIC

NOTE:  
Skew Angle and  $\alpha$  measured positive in clockwise direction from a line perpendicular to the joint. See Structures Plans, Expansion Joint Data Table.

REVISIONS

DATE	BY	DESCRIPTION	DATE	BY	DESCRIPTION
07/01/09	SJN	Changed MOVEMENT SCHEMATIC detail			

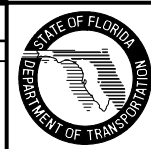

2008 Interim Design Standard

STRIP SEAL EXPANSION JOINT

Interim Date	Sheet No.
07/01/09	2 of 3
Index No.	
21100	