

CASE 1

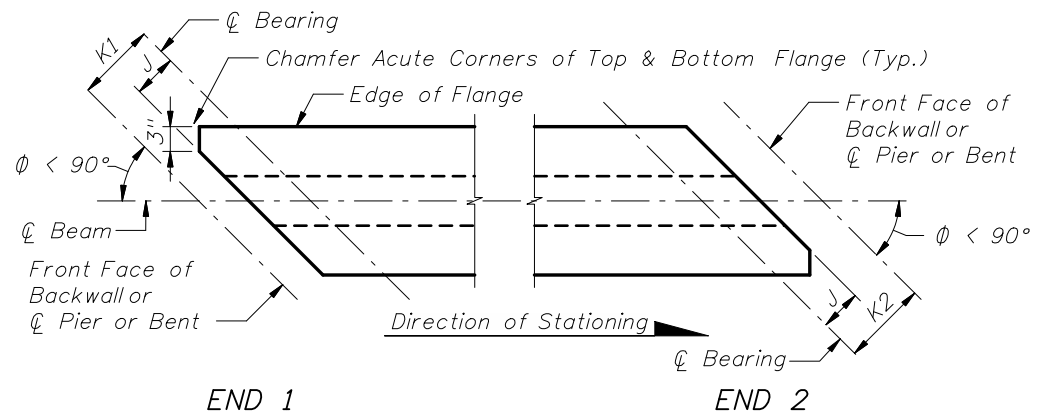

CASE 2

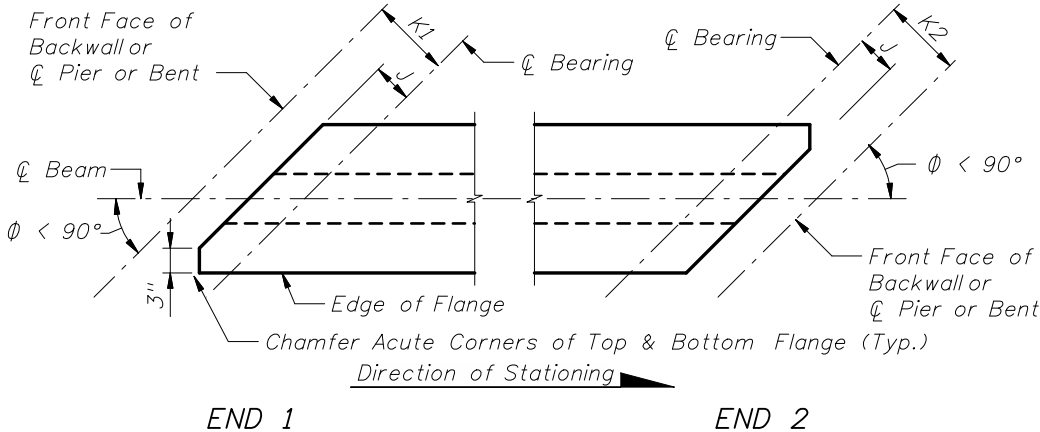

CASE 3

SCHEMATIC PLAN VIEWS AT BEAM ENDS

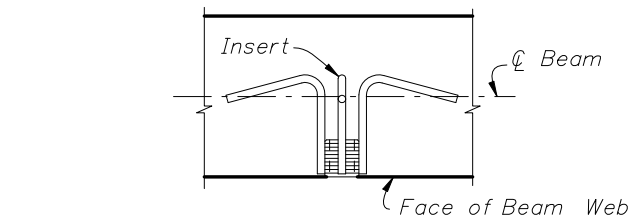

PLAN SECTION THRU BEAM WEB AT INSERT FOR DIAPHRAGM REINFORCING
(When Intermediate Diaphragms are Required by Design)

INSERT NOTES

1. Provide 1"Ø, zinc-electroplated, ferrule wing nut or coil inserts, UNC threads, 1/0 minimum gage wire, not more than 4" in depth with a minimum ultimate tensile strength of 11,400 lbs. in 4,000 p.s.i. concrete.
2. If inserts are needed on both sides (faces) of beam webs, an assembly as long as the thickness of the beam web, consisting of two (2) ferrule or coil inserts attached by two (2) or more struts may be utilized. The connecting struts shall have a minimum ultimate tensile strength of 11,400 lbs.
3. Inserts for diaphragm reinforcing are required at each end of each intermediate diaphragm shown on the Beam Framing Plan. See Superstructure and Beam Framing Plans for longitudinal location of inserts for each face of beam.

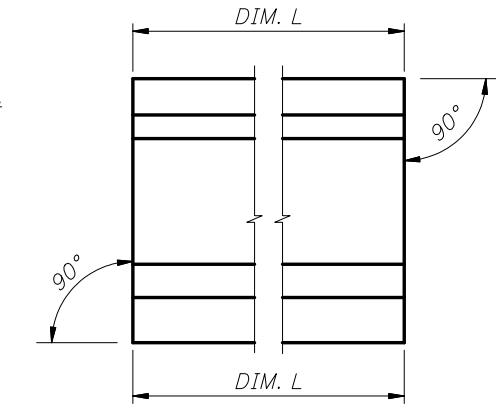

CONDITION 1
(P = 0.0)

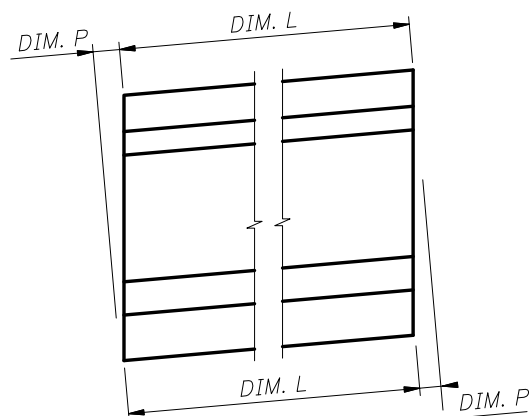

CONDITION 2

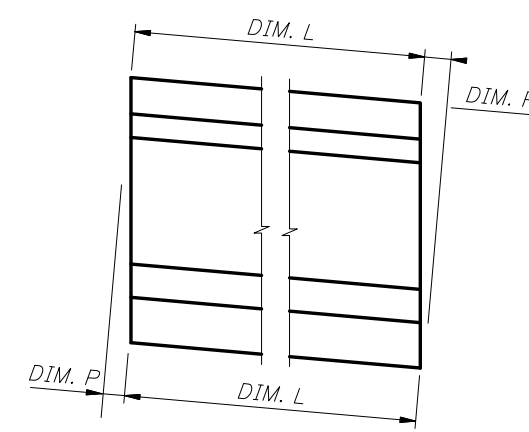

CONDITION 3

SCHEMATIC END ELEVATIONS OF BEAMS
(Showing Vertical Bevel of Beam End)

BEAM NOTES

1. All bar dimensions are out-to-out.
2. Place one (1) Bar 4K or 5K or 5Z at each location as detailed alternating the direction of the ends for each bar (see "ELEVATION AT END OF BEAM", Index Nos. 20120, 20130, 20140, 20150, 20160, 20172 and 20178).
3. Bars 4L shall be bent prior to the beam leaving the prestressing yard. Bars 4L shall be bent parallel to the ends of the beams.
4. Caution should be used with Bars 4L in the ends of exterior beams to assure the bent portion of the bar is properly oriented so that the bar will be embedded in the diaphragm concrete.
5. Strands N shall be either ASTM A416, Grade 250 or Grade 270, seven-wire strands 3/8" Ø or larger, stressed to 10,000 lbs. each.
6. Unless otherwise noted, the minimum concrete cover for reinforcing steel shall be 2".
7. At option of the Contractor, welded deformed wire reinforcement may be used in lieu of Bars 3D, 4K, 5K, 4L and 5Z except as noted below, provided the wire sizes and spacing match those shown on the Standard Beam Details sheet for these bars. In this event, Bars 4K or 5K and 5Z may be fabricated with the omission of the lower outstanding leg provided that two longitudinal wires are placed (welded) at the lower end of the bar. The first (lower) wire shall be located 1" from the end of Bars 4K or 5K and 5Z and the second wire 2" minimum from the first wire, but no less than 1/4 of the beam depth from mid-depth of the beam. In addition, Bars 5Z may consist of pairs of bars with the cross sectional area of the pair equal to or greater than the shown conventional single bar. Welded wire reinforcement shall conform to ASTM A497.
8. Install Safety Sleeves 1'-10" from ends of beam and spaced on 8'-0" (Max.) centers. Shift Bars 4K or 5K locally to allow placement. Safety Sleeves shall be :
2 1/2" NPS x 5" Sch. 40 PVC Pipe with Cap for Type III, IV, V, VI, FBT 72 and FBT 78 Beams;
1 1/2" NPS x 5" Sch. 40 PVC Pipe with Cap for Type II Beams.
Holes shall be free of debris and water prior to casting deck.
9. For beams with skewed end conditions, the end reinforcement, defined as Bars 3D1, 3D2, 4K, 5K, 4M1, 4M2, 4Y or 5Y and 5Z placed within the limits of the spacing for Bars 3D (approximately 1.5 times the overall beam depth) in "ELEVATION AT END OF BEAM", shall be placed parallel to the skewed end of the beam. Bars 4K or 5K and 4M3 located beyond the limits of Bars 3D shall be placed perpendicular to the longitudinal axis of the beam. Placement of Bars 3D1, 3D2, 4M1 and 4M2 correspond to END 1 and END 2 respectively, as shown in the beam "ELEVATION". For Bars 3D1 and 3D2, Dimension B and the overall length shall be adjusted to fit the width of the bottom flange measured parallel to the skew. For Bars 4M1 and 4M2 the overall length shall be adjusted to fit the width of the top flange as measured parallel to the skew. Fan Bars 4M1 and 4M2 as needed to maintain minimum clearance (1 1/2") between the bars at the transition to Bars 4M3 and field cut to length to maintain minimum cover.
10. Bars 4M1, 4M2 and 4M3 are applicable to AASHTO Beam Types V and VI, and Florida Bulb-T's.
11. For Beams with vertically beveled end conditions when "DIM. P" exceeds 1", Bars 3D1, 3D2, 4K, 5K, 4Y or 5Y and 5Z shall be placed parallel to the end of the beam, within the limits of Bar 4L.
12. Welded deformed wire reinforcement shall not be used for the end reinforcement (Bars 3D1, 3D2, 4K or 5K and 5Z) for beams with skewed end conditions or vertically beveled end conditions when "DIM. P" exceeds 1".
13. Bars 4K or 5K and 5Z shall be placed and tied to the fully bonded strands in the bottom row (see "STRAND PATTERN").
14. At the Contractor's option Bars 3D1 and 3D2 may be fabricated as a two-piece bar with a 1'-2" lap splice of the bottom legs.
15. For referenced Dimensions, Angles and Case Numbers see Table of Beam Variables in Structures Plans.

INSTRUCTIONS TO DESIGNER:

To limit Bursting Forces the maximum prestress force at the beam ends from fully bonded strands must be limited to the following:

Beam Type	Max. Bonded Prestress Force	Index No.	Last Revision Date
AASHTO Type II	755 Kips	20120	7/1/05
AASHTO Type III	1100 Kips	20130	7/1/05
AASHTO Type IV	1470 Kips	20140	7/1/05
AASHTO Type V	1630 Kips	20150	7/1/05 or later
AASHTO Type VI	1815 Kips	20160	7/1/05 or later
Florida Bulb-T 72	1470 Kips	20172	7/1/05 or later
Florida Bulb-T 78	1730 Kips	20178	7/1/05 or later

No losses shall be applied when calculating the Bonded Prestress Force. The reinforcing in the ends of the beams must not be modified without the approval of the State Structures Design Engineer.

REVISIONS

DATE	BY	DESCRIPTION	DATE	BY	DESCRIPTION
07/01/08	SJN	Added "SUPPLEMENTAL INTERFACE SHEAR REINFORCING DETAIL" & note 16. Changed "fabric" to "reinforcement" and Insert Detail.	12/09/08	SJN	Deleted Note 16 and "SUPPLEMENTAL INTERFACE SHEAR REINFORCING DETAIL".

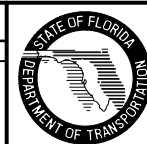

2008 Interim Design Standard

TYPICAL AASHTO AND BULB-T BEAM DETAILS AND NOTES

Interim Date 12/09/08	Sheet No. 1 of 1
Index No. 20110	