

NOTES

SPECIFICATIONS:

1. General Specifications:
 - The Florida Department of Transportation "Standard Specifications for Road and Bridge Construction", Current Edition and Supplements as Amended.
2. Design Specifications:
 - a. Florida Department of Transportation (FDOT) "Structures Design Guidelines", Current Edition.
 - b. American Association of State Highway and Transportation Officials (AASHTO) "LRFD Bridge Design Specifications", Current Edition.
 - c. AASHTO-AGC-ARTBA Task Force 27 (Ground Modification Techniques), "Insitu Soil Improvement Techniques", January 1990.

DESIGN CRITERIA:

1. Design is based on the assumption that the material contained within the reinforced soil volume, methods of construction and quality of prefabricated materials are in accordance with Specification Section 548.
2. It is the responsibility of the Engineer to determine that the factored bearing pressure shown for the wall does not exceed the factored bearing resistance of the foundation for that specific wall location.
3. The Wall Company is responsible for internal stability of the wall. External stability design, including foundation and slope stability, is the responsibility of the Engineer.

SOIL PARAMETERS:

1. See wall control drawings for soil characteristics of foundation material to be used in the design of the wall system. The Contractor must provide soil design parameters for backfill material based on the actual soil characteristics utilized at the site. Provide the values of unit weight, cohesion and internal friction angle in the Shop Drawings.

MATERIALS:

1. Provide soil reinforcement in accordance with Specification Section 548.
2. For additional material notes, see Wall Company General Notes.

CONSTRUCTION:

1. Walls must be constructed in accordance with Specification Section 548 and the Wall Company's instructions.
2. For location and alignment of retaining walls, see Wall Control Drawings.
3. If present, consider in design and analysis and locate manholes and drop inlets as shown on wall elevations.
4. Refer to Plan and Elevation sheets of individual walls for minimum reinforcement strip/mesh length, factored bearing resistances, minimum wall embedment and anticipated long term and differential settlements.
5. It is the Contractor's responsibility to determine the location of any guardrail posts behind retaining wall panels. Prior to placement of the top layer of soil reinforcement, individual reinforcing strips/mesh may be skewed horizontally (15° maximum) to avoid the post locations if authorized by the Engineer. No cutting of soil reinforcement is allowed unless shown on shop drawings and approved by the Engineer. Any damage done to the soil reinforcement due to installation of the guardrail must be repaired by the Contractor at the Contractor's expense. All repair methods must be approved by the Engineer.
6. If existing or future structures, pipes, foundations or guardrail posts within the reinforced soil volume interfere with the normal placement of soil reinforcement and specific directions have not been provided on the plans, the Contractor must notify the Engineer to determine what course of action should be taken.
7. The Contractor is responsible for gradually deflecting upper layer(s) of soil reinforcement downward (15° maximum from horizontal) to avoid cutting soil reinforcement and conflicts with paving and subgrade preparation. The Contractor's attention is directed especially to situations where roadway superelevation and/or soil mixing are anticipated.

CONSTRUCTION (CON'T.):

8. Piles within the soil volume must be driven prior to construction of the retaining wall. The portion of the pile within the soil wall volume must be wrapped with polyethylene sheeting in accordance with Specification Section 459. Drive piles located within soil volume prior to construction of the retaining wall, unless a method to protect the structure, acceptable to both the Engineer and Wall Company, is proposed and approved in writing.
9. A structural extension of the connection of the retaining wall panel to soil reinforcement must be used whenever necessary to avoid cutting or excessive skewing (greater than 15°) of the soil reinforcement around obstructions (i.e., piles, pipes, etc.).

QUALIFIED PRODUCTS LIST

1. Manufacturers seeking approval of proprietary retaining wall systems for inclusion on the Qualified Products List as pre-approved wall system suppliers must submit a QPL Product Evaluation Application along with design documentation, vendor drawings, wall system construction manual and other information as required in the Retaining Wall System QPL Acceptance Criteria showing the proprietary wall system is designed to meet all specified requirements. Project specific Shop Drawings are required for QPL approved wall systems (see Shop Drawing Requirements below).

SHOP DRAWING REQUIREMENTS

The successful bidder must submit the final design of the wall for review as Shop Drawings. Details and Design Criteria shown on the Shop Drawings must not deviate from those shown on the approved QPL Vendor Drawings. The Shop Drawings must include detailed design computations and all details, dimensions and quantities necessary to construct the wall. The design and fully detailed plans must be prepared as required by FDOT Specification Section 548 and must include, but not be limited to, presentation of required information as follows:

1. Provide an elevation view of the wall indicating:
 - a. Elevations/Stations at the top and bottom of wall, for Begin/End Retaining Wall, all breaks in vertical alignment, all whole stations and every 25 foot station increments.
 - b. Length, size and designation of soil reinforcement in elevation view.
 - c. Location of the proposed final ground line.
2. Provide a plan view detailing the horizontal alignment and offsets from the horizontal control line(s) to the exterior face of the wall.
3. Show in plan and elevation all utilities, drainage structures, drainage pipes, etc. that affect the wall(s). Locate in the plan view all piles within the reinforced earth volume, as shown on Foundation Layout Drawings.
4. Provide general notes and design parameters on the Shop Drawings. Include design soil characteristics and all other pertinent notes required for construction of the walls. Provide the factored bearing resistance and factored bearing pressure for each wall height increment.
5. Show the limits of the reinforced soil volume.
6. Show complete details for construction of wall around obstructions. Show details for placement of soil reinforcement at acute corners.
7. Show complete details addressing conflicts between soil reinforcement and embedments in the reinforced soil volume.
8. Show complete details where walls of different types intersect/influence one another.
9. Provide fully detailed design calculations for each wall height increment detailed in the Shop Drawings. Submit Shop Drawings and design calculations signed and sealed by a Professional Engineer registered in the State of Florida.

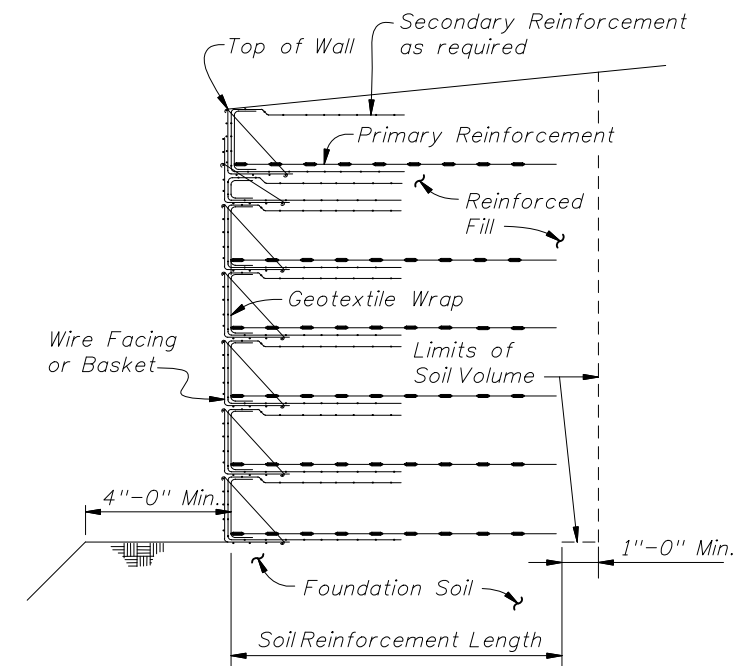

**TYPICAL RETAINING WALL SECTION
(Showing Limits of the Reinforced Soil Volume)**

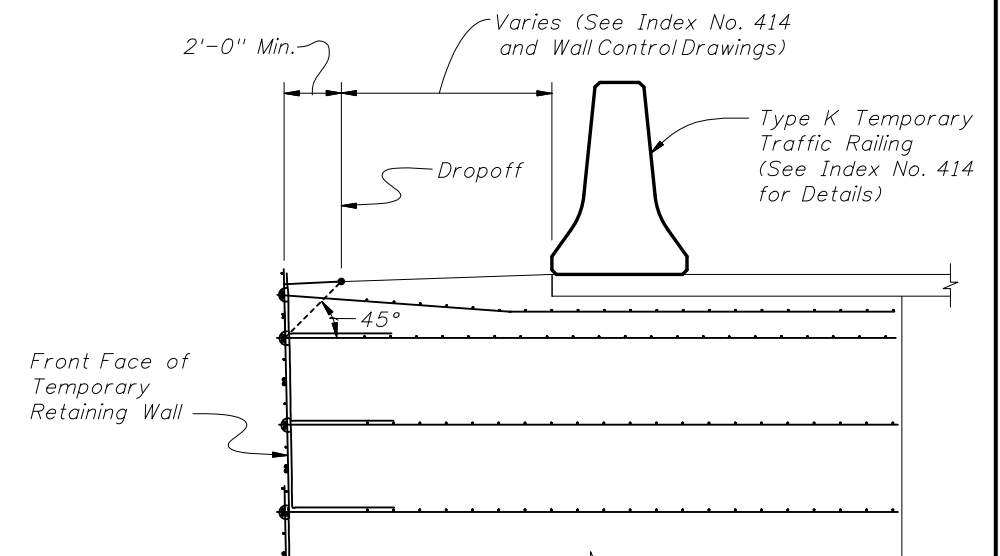

**TEMPORARY TRAFFIC RAILING
PLACEMENT DETAIL**

GENERAL NOTES AND DETAILS

	2008 FDOT Design Standards	Last Revision 07/01/05	Sheet No. 1 of 1
	TEMPORARY RETAINING WALL SYSTEMS		
	Index No. 5301		