

PLAN
SPREAD FOOTING ADJACENT TO SKEWED APPROACH SLAB AND WITH BARRIER WALL INLET

EXPANSION JOINT DETAIL
(Spread Footing expansion joints are required at 3/4" open joints in Traffic Railing/Sound Barrier)

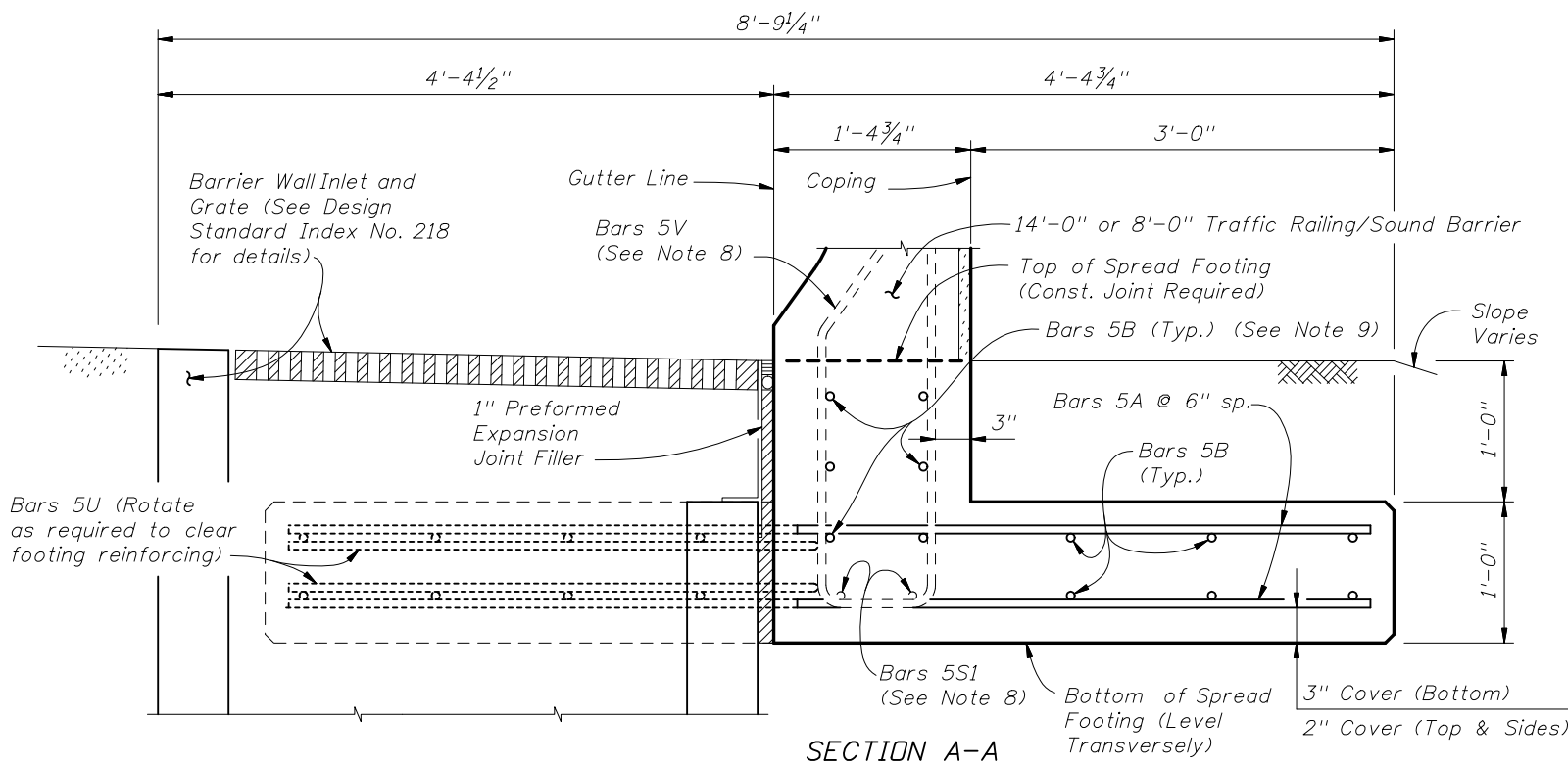

SECTION A-A
SECTION THRU SPREAD FOOTING AND BARRIER WALL INLET
(Bars 5P, 5R and 5S1 in Traffic Railing/Sound Barrier not shown for clarity)

- NOTES
- CONSTRUCTION REQUIREMENTS: Construct the Spread Footing level transversely and expansion joints plumb; do not construct the spread footing perpendicular to the roadway surface. Slip forming is not permitted.
 - CONCRETE: Use Class II concrete for slightly aggressive environments. Use Class IV concrete for moderately or extremely aggressive environments. Concrete will be in accordance with Specification Section 346.
 - REINFORCING STEEL: Provide Grade 60 reinforcing steel in accordance with Specification Section 931. Dowel Load Transfer Devices will be ASTM A 36 smooth round bar and hot-dip galvanized in accordance with Specification Section 962. Install Dowel Load Transfer Devices in accordance with Specification Section 350.
 - Construct 3/4" Expansion Joints plumb and perpendicular or radial to Gutter Line. Provide at 90'-0" maximum intervals as shown.
 - Provide and install Preformed Expansion Joint Filler in accordance with Specification Section 932.
 - Construct 1/2" V-Grooves plumb and provide at 30'-0" maximum intervals as shown. Space V-Grooves equally between 3/4" Expansion Joints and/or Begin or End Spread Footing. V-Groove locations are to coincide with V-Groove locations in the Railing/Sound Barrier.
 - FILL REQUIREMENTS: Shoulder or Roadway Pavement or Fill is required on top (1'-0" minimum depth) for the entire length of the spread footing on both sides of the Railing/Sound Barrier. See Section B-B for details.
 - See Index No. 5210 for Bars 5V and 5S1.
 - Place 6 ~ Bars 5B inside Stirrup Bars 5V as shown.
 - Spacing shown is along the Gutter Line.
 - Work this Standard Drawing with one or both of the following:
 - Index No. 5210 - Traffic Railing/Sound Barrier (8'-0").
 - Index No. 5211 - Traffic Railing/Sound Barrier (14'-0").

CROSS REFERENCE:
For Section B-B and Detail "A", see Sheet No. 2.

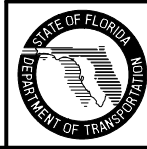

2008 FDOT Design Standards

TRAFFIC RAILING/SOUND BARRIER
T-SHAPED SPREAD FOOTING

Last Revision	Sheet No.
07/01/05	1 of 2
Index No.	
5213	

REINFORCING STEEL BENDING DIAGRAMS

BILL OF REINFORCING STEEL		
MARK	SIZE	LENGTH
A	5	6'-8"
B	5	AS REQ'D.
U	5	11'-0"
DOWEL	1" ϕ Smooth Bar	2'-0"

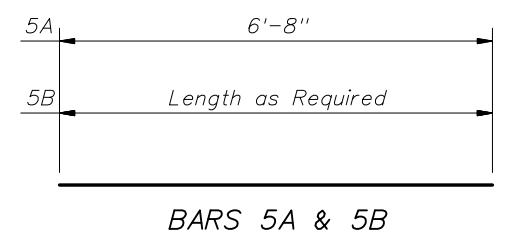

BARS 5A & 5B

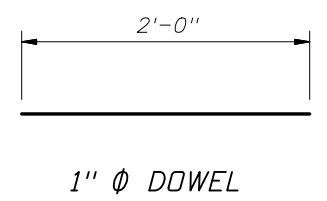

1" ϕ DOWEL

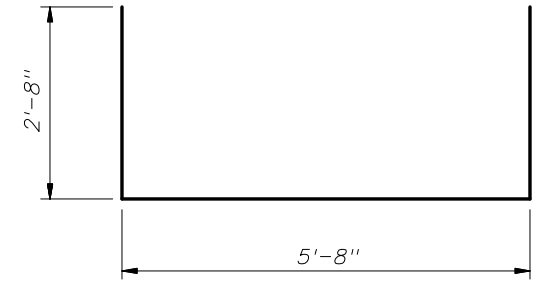

BAR 5U

REINFORCING STEEL NOTES:

1. All bar dimensions in the bending diagrams are out to out.
2. All reinforcing steel at the open joints will have a 2" minimum cover.
3. Lap splices for Bars 5B will be a minimum of 2'-2".
4. The Contractor may use Welded Wire Fabric when approved by the Engineer. Welded Wire Fabric will conform to ASTM A 497.

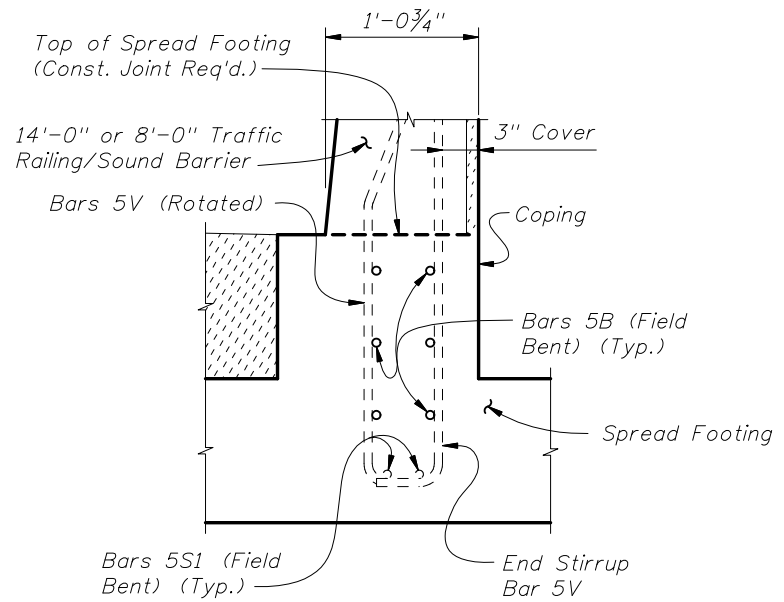

PARTIAL END VIEW OF RAILING END TRANSITION FOR GUARDRAIL ATTACHMENT (Showing Bars 5V, Bars 5S1 and Bars 5B inside of Stirrup Bars 5V)

NOTE: See Index No. 5210, Detail "A" for details.

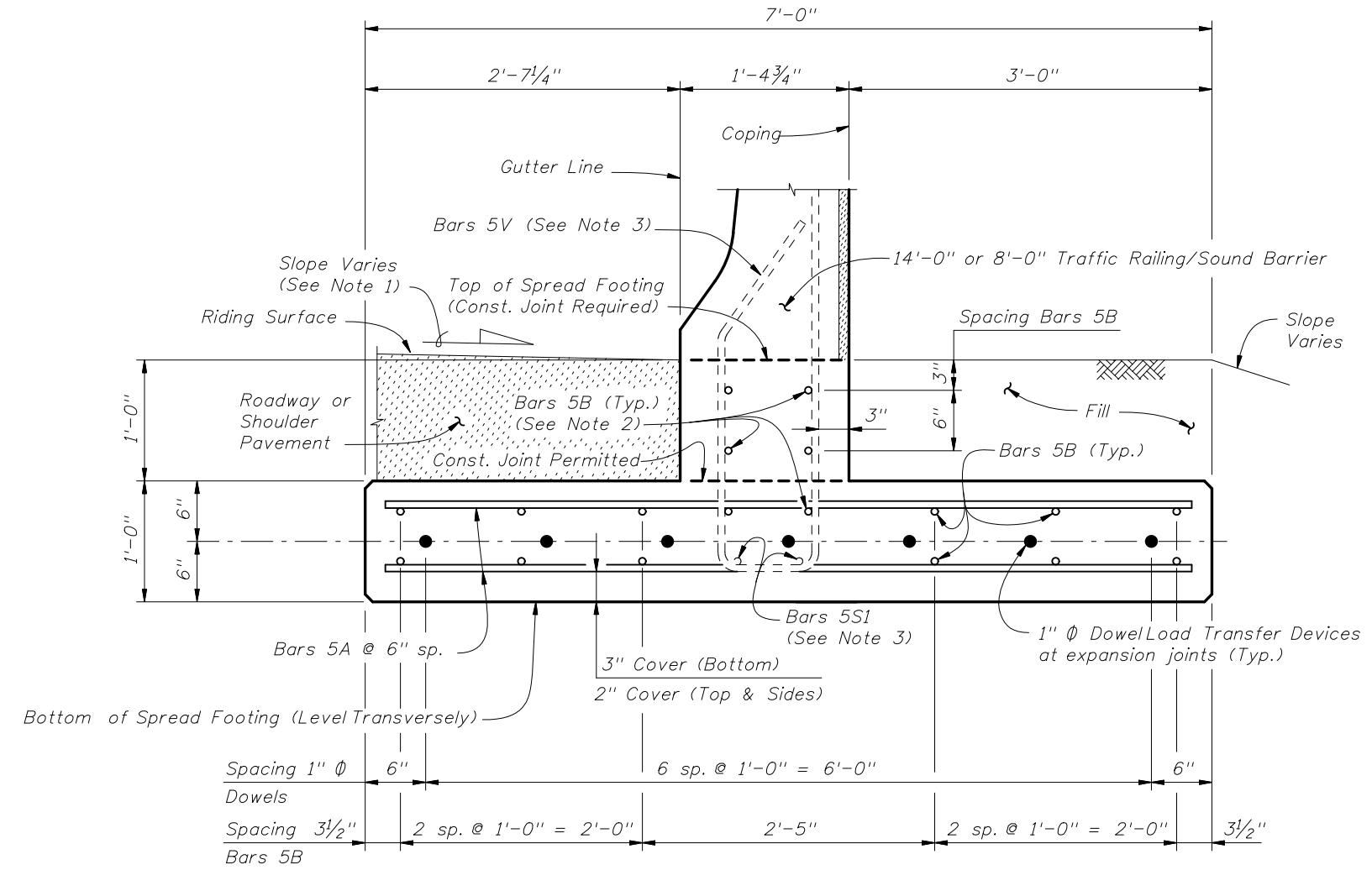

SECTION B-B
TYPICAL SECTION THRU SPREAD FOOTING
(Bars 5P, 5R and 5S1 in Traffic Railing/Sound Barrier not shown for clarity)

NOTES:

1. Match Cross Slope of Travel Lane or Shoulder.
2. Place 6 ~ Bars 5B inside Stirrup Bars 5V as shown.
3. See Index No. 5210 for Bars 5V and Bars 5S1.

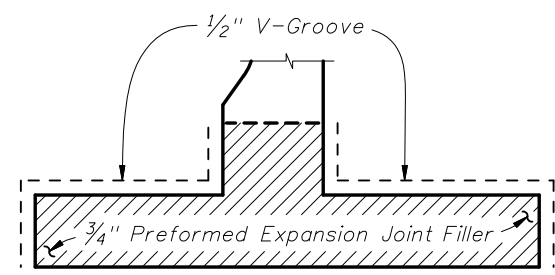

DETAIL "A"

(Showing Locations of 1/2" V-Grooves and 3/4" Preformed Expansion Joint Filler)

ESTIMATED T-SHAPED SPREAD FOOTING QUANTITIES

ITEM	UNIT	QUANTITY
Concrete (Footing)	CY/Ft.	0.311
Reinforcing Steel (Typical)	LB/Ft.	51.80
Additional Reinf. @ Expansion Joint	Lb.	37.38

Note: The reinforcing steel quantity accounts for the difference between the shorter Stirrup Bars 5V for junction slabs or bridges and the longer Stirrup Bars 5V for spread footings.

CROSS REFERENCE:

For location of Section B-B, see Sheet 1.



2008 FDOT Design Standards

TRAFFIC RAILING/SOUND BARRIER
T-SHAPED SPREAD FOOTING

Last Revision 07/01/05	Sheet No. 2 of 2
Index No. 5213	