

TYPICAL PANELS AND POSTS



2008 FDOT Design Standards

PRECAST SOUND BARRIERS
- RECESSED PANEL OPTION

Last Revision	Sheet No.
07/01/06	1 of 4
Index No.	
5203	

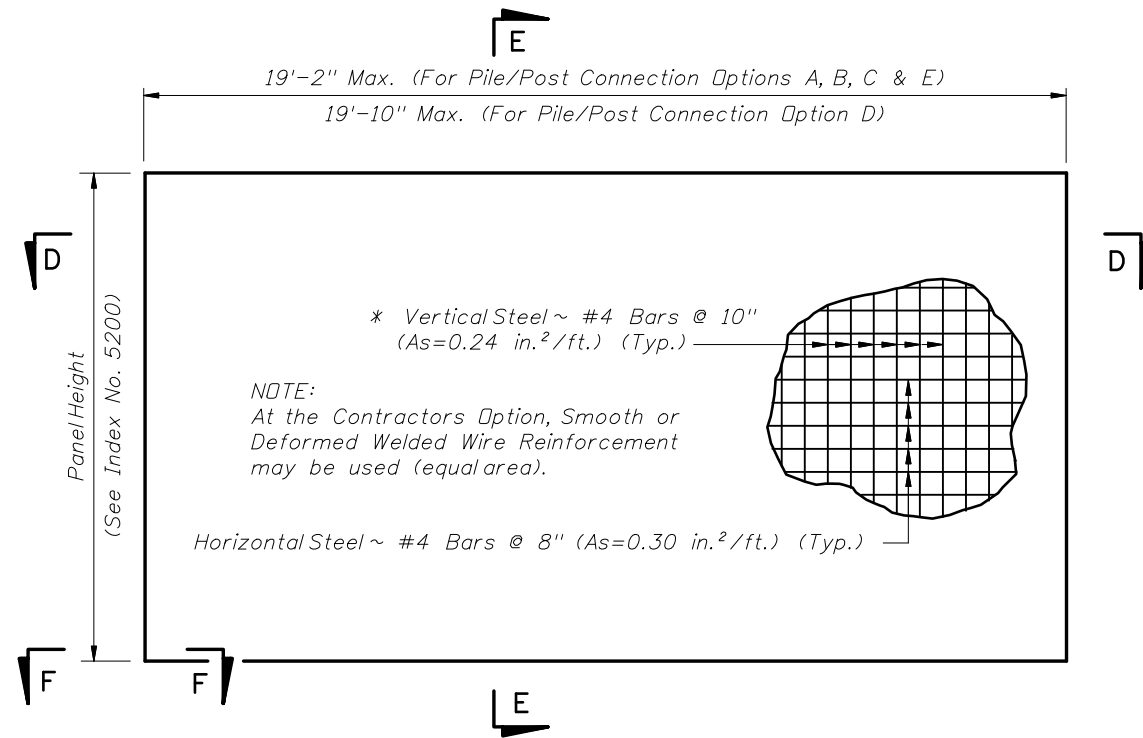

TYPICAL PANEL ELEVATION

* In lieu of utilizing the pick up points below, panels may be cast vertically or cast horizontally then tilted upright using tilt-tables prior to lifting from form. In this case, the vertical steel may be reduced to #4 Bars @ 1'-3" (As=0.15 in.²/ft.).

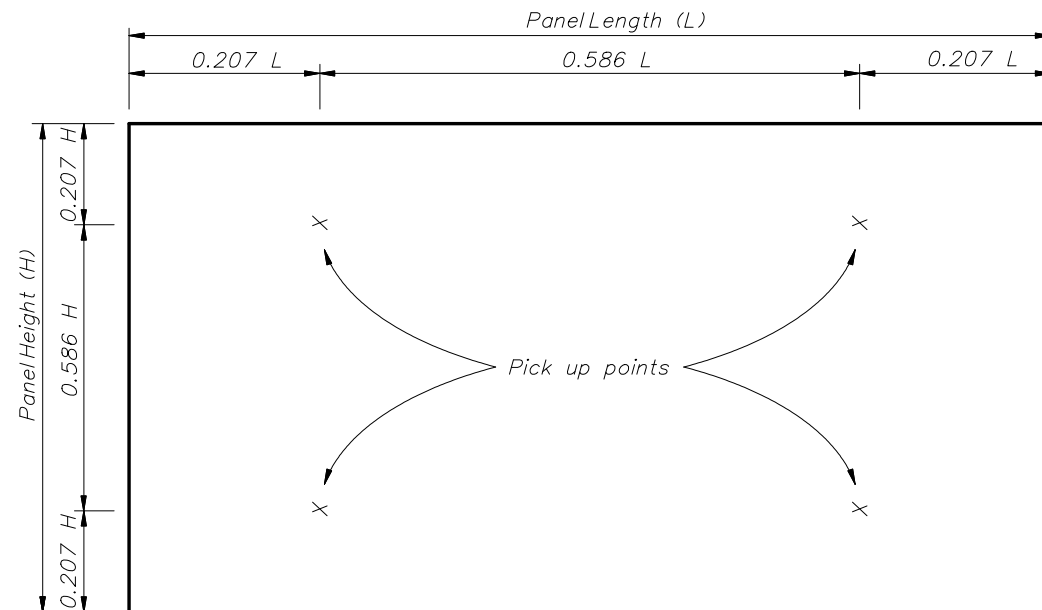

REQUIRED PICK UP POINTS FOR PANELS
(Panels shall be rotated about long axis only)

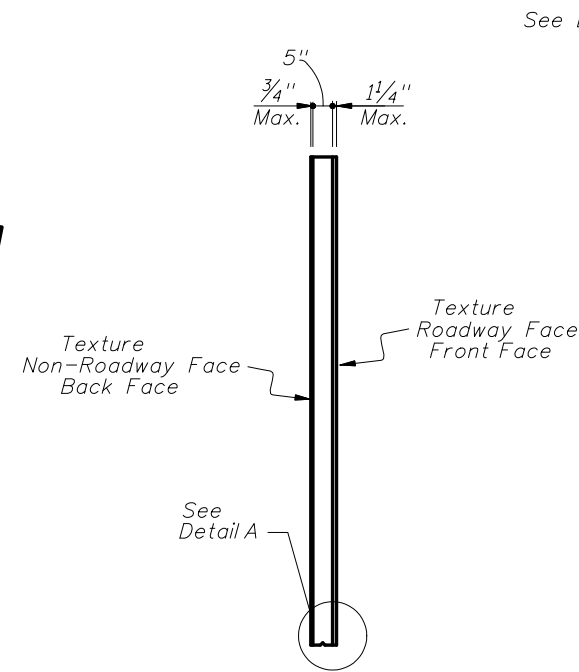

SECTION E-E

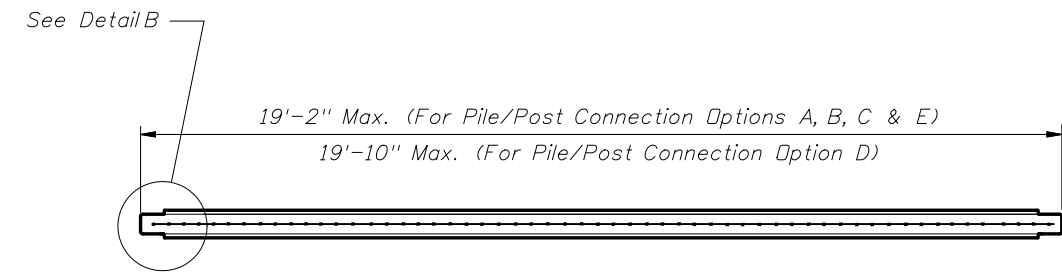

SECTION D-D

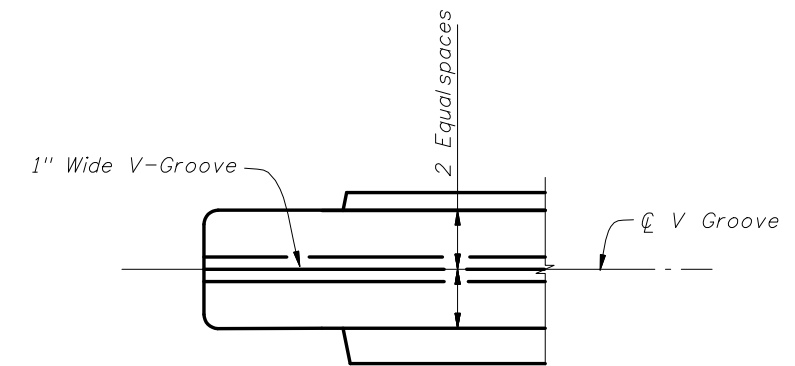

SECTION F-F

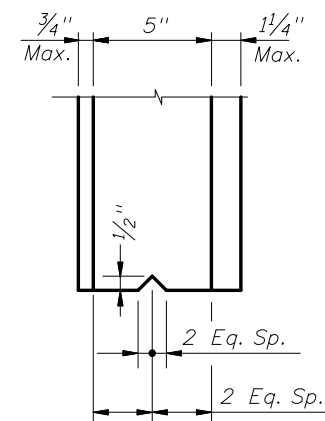

DETAIL A

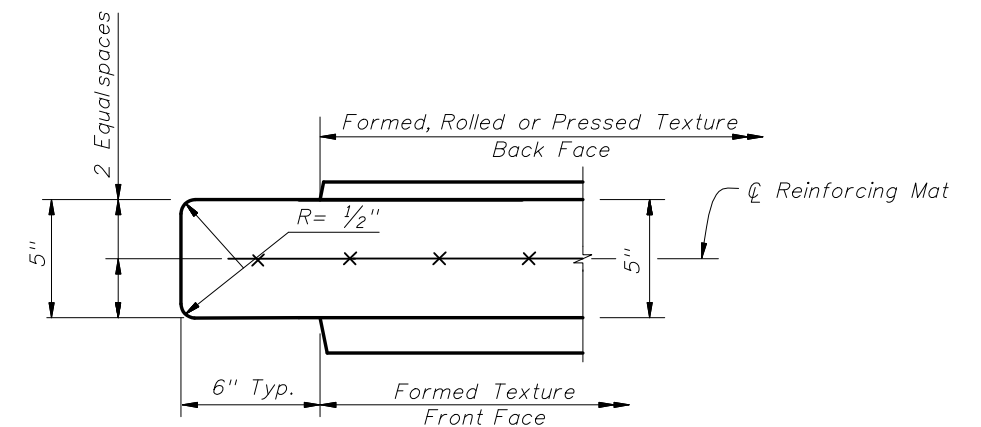

DETAIL B
(Typical both ends)

TYPICAL PANELS AND POSTS

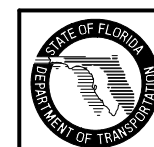

2008 FDOT Design Standards

PRECAST SOUND BARRIERS
- RECESSED PANEL OPTION

Last Revision
07/01/06

Sheet No.
2 of 4

Index No.
5203

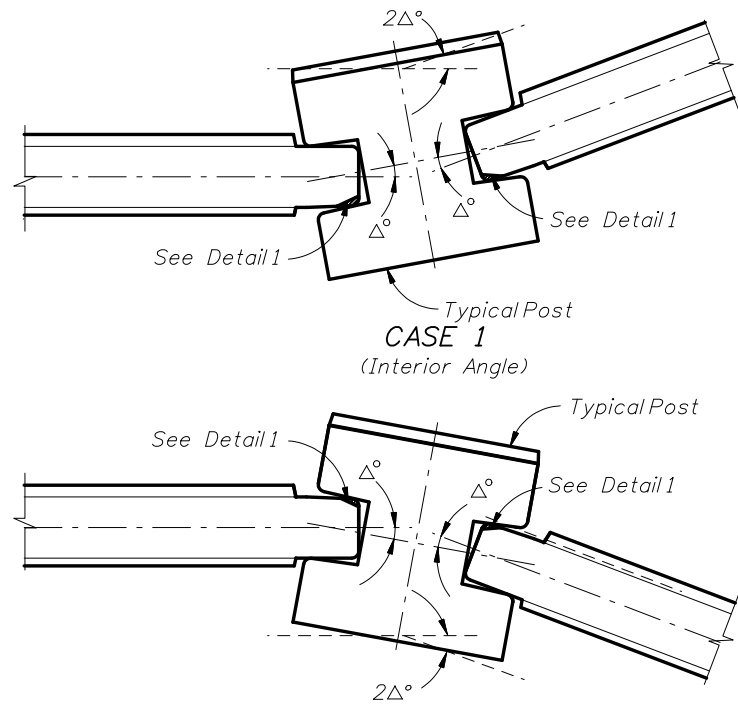

CASE 1
(Interior Angle)

CASE 2
(Exterior Angle)

PIVOTING POINT DETAILS

NOTE: The shop drawings shall include specific pivoting point details of panel ends at locations where the deflection angle (2Δ) between panels exceeds 20° .

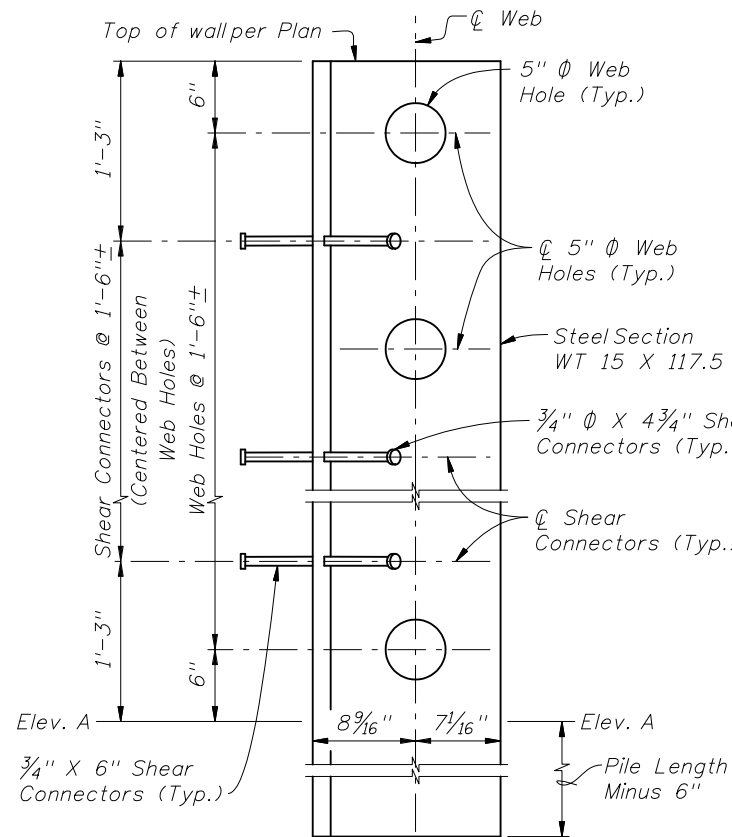

Web Hole & Shear Connector Spacing Detail
(Concrete not shown for clarity. For limits of concrete see Index No. 5205, Sheet No. 4 of 7.)

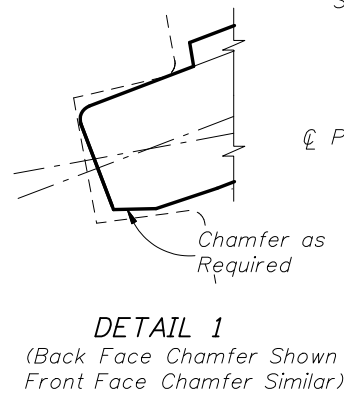

DETAIL 1
(Back Face Chamfer Shown
Front Face Chamfer Similar)

Total vertical reinforcing shall have an area of not less than that of typical posts. See Note 1.

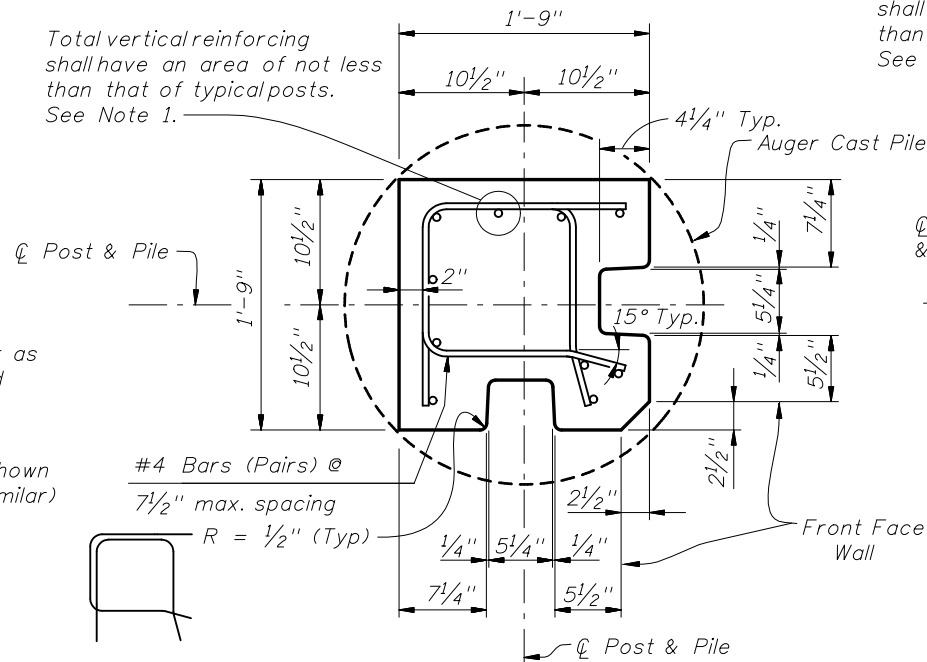

SPECIAL POSTS FOR 90° CORNERS FOR
PILE/POST CONNECTION OPTIONS A, B & E
Collars for Special Posts shall be 3'-6" Ø

Total vertical reinforcing shall have an area of not less than that of typical posts. See Note 1.

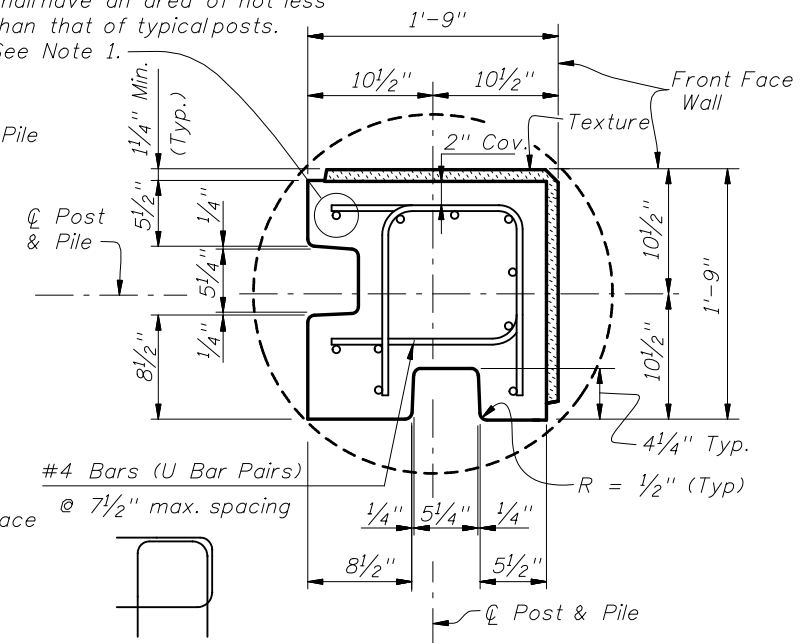

SPECIAL POSTS FOR 90° CORNERS FOR
PILE/POST CONNECTION OPTIONS C & D
Collars for Special Posts shall be 3'-6" Ø

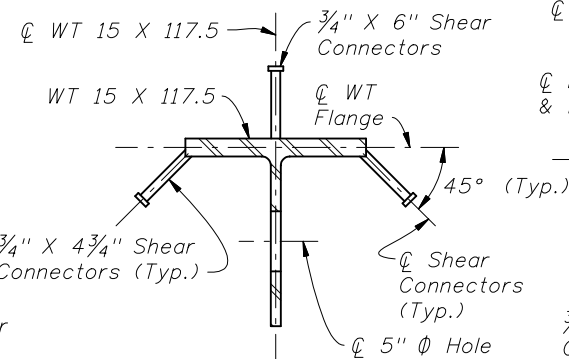

WT 15 X 117.5 Post Detail For
Pile/Post Connection Options C & D

NOTE: The WT 15 X 117.5 Section shall extend into the Auger Cast Pile.

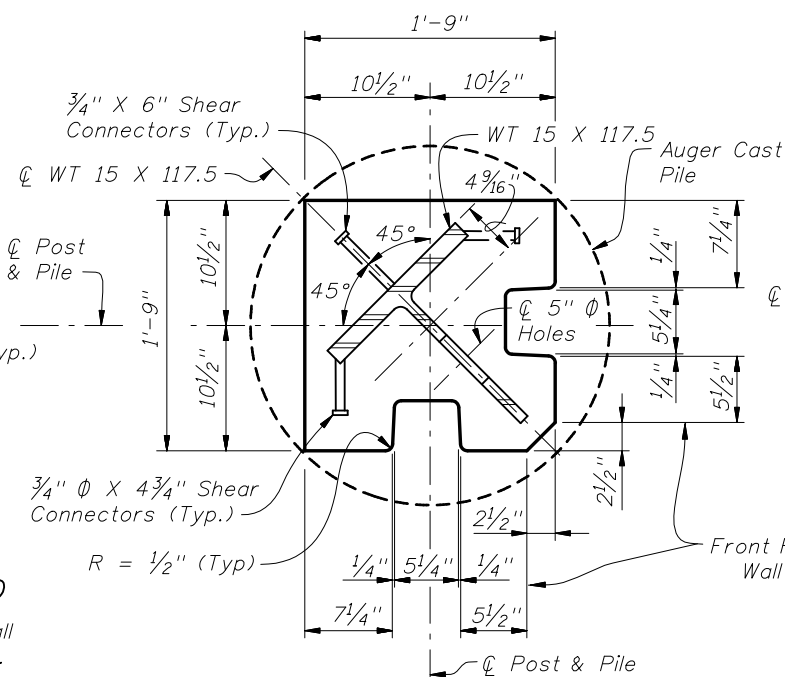

PANEL PLAN

NOTES:

1. For Table of Reinforcing Steel Sizes, see Index No. 5206.
2. For Pile/Post Connection Options A through E, see Index No. 5205.
3. For Post & Pile Lengths, see Index No. 5206.

SPECIAL PANELS AND POSTS



2008 FDOT Design Standards

PRECAST SOUND BARRIERS
- RECESSED PANEL OPTION

Last Revision	Sheet No.
07/01/05	3 of 4
Index No.	
5203	

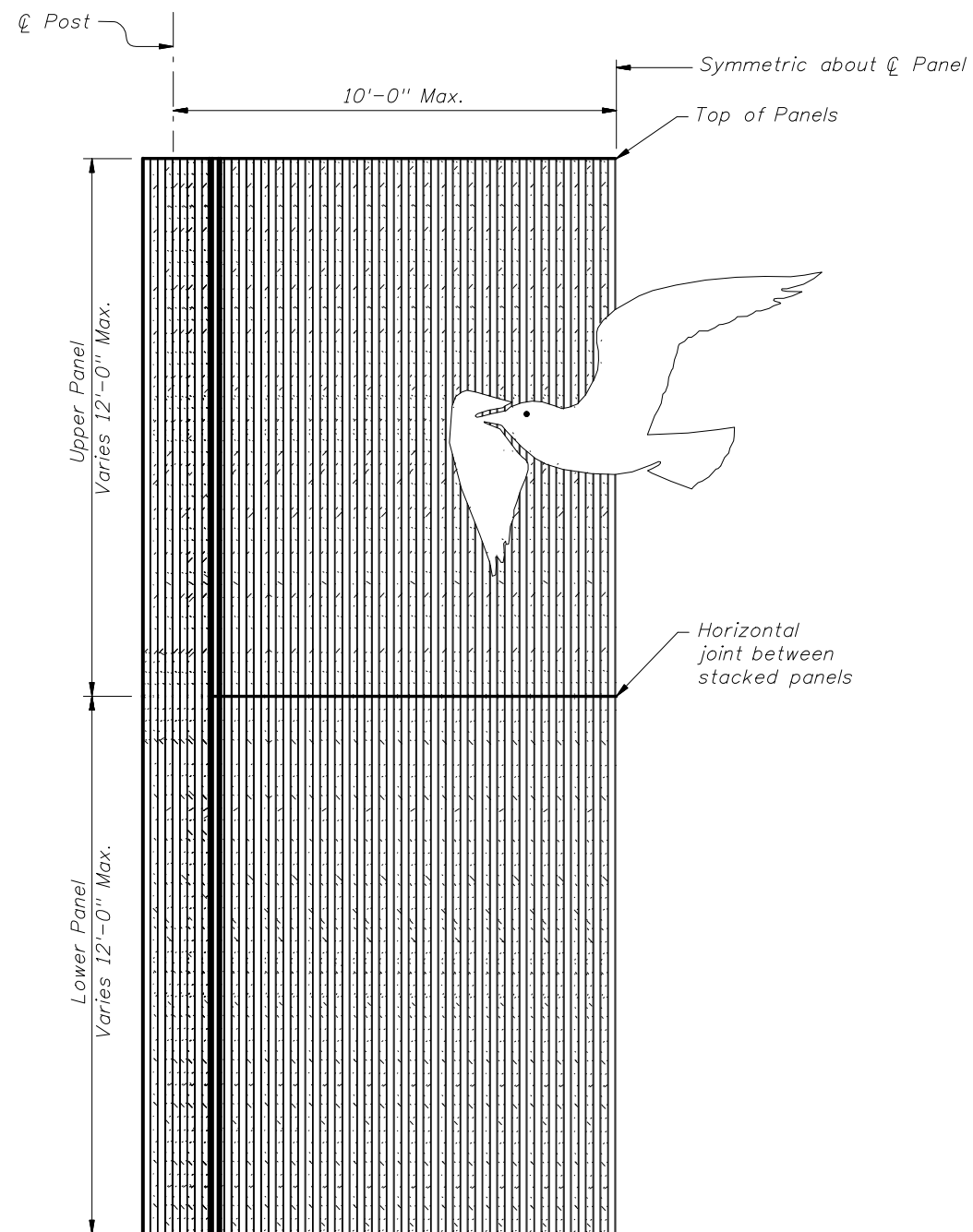

Back Face Panel Texture
(Formed, Rolled or Pressed
into Plastic Concrete)

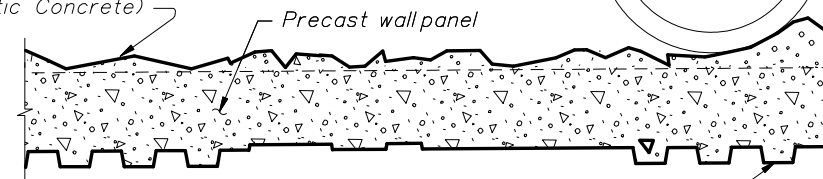

Front Face Panel Texture
(Formed)

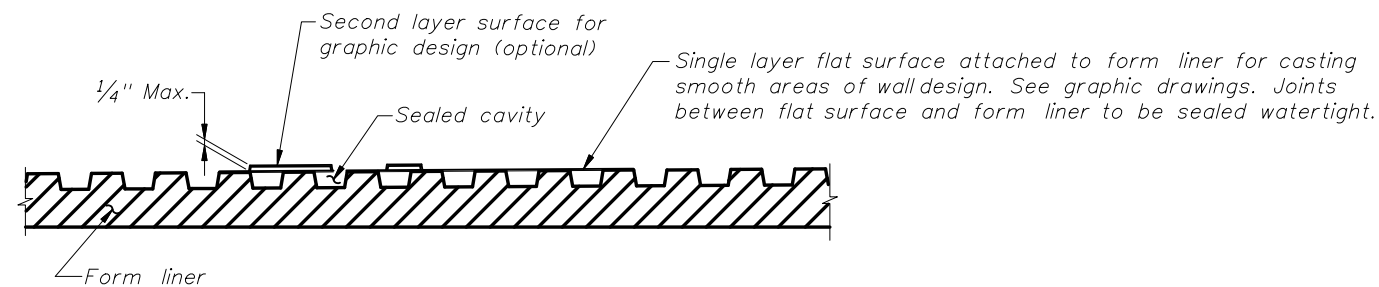

TYPICAL FORMING DETAIL
(Front Face Panel Texture Type "H" Shown.)
(Back Face Panel Texture Type "D" Shown.)

NOTES:

1. Contractor shall submit specific form liner samples for approval by the Engineer.
2. Textures and graphics shown are for demonstration purposes only. See Wall Control Drawings for project specific texture and graphic requirements.

HALF ELEVATION
(Pile/Post Connection Options A, B, C and E Shown.)
(Front Face Panel Texture Type "H" and Front Face Post Texture Type "H" Shown.)
(Graphic Type LG-3 Shown.)

