

**GENERAL NOTES FOR
CONCRETE PAVEMENT SUBDRAINAGE**

- No trench greater than 2' in depth will be allowed overnight. Trenches shall be barricaded at all times.
- Concrete pavement subdrainage shall be constructed adjacent to the low edge of the roadway pavement and under travel lanes, auxiliary pavement and shoulders, as called for in the plans. When the low edge shifts between outside and inside edges of pavement the concrete pavement subdrainage shall extend 50' beyond and begin 50' before the flat point (100' overlap).

Concrete pavement subdrainage shall be placed on the low side of ramps of crossroad terminals.
- Concrete pavement subdrainage shall be constructed on a grade parallel with the edge of pavement profile, except on profiles flatter than one-tenth percent (0.10%) the concrete pavement subdrainage shall be constructed on a grade of one-tenth percent (0.10%).
- Immediately prior to placing the filter fabric the entire vertical face of the concrete pavement shall be cleaned to remove adhering base material and soil.
- The Contractor shall devise a procedure for holding the filter fabric in position on the vertical face of the trench. The procedure must be approved by the Engineer prior to placement of the draincrete.
- The upper end of each separate run of the concrete pavement subdrainage pipe shall be capped.
- Outlet pipes shall be constructed at a maximum of 500' intervals. Elbows or $\frac{1}{8}$ bends shall be used to connect the outlet pipe to the concrete pavement subdrain pipe. The elbows or bends shall be of the same material as the outlet pipe but compatible with the pipe.

When directed by the Engineer, outlet pipes shall be stubbed into existing inlets or into existing ditch pavements at an elevation 6" above the inlet flowline or ditch bottom. Concrete apron and bordering sod are not required for stubbed outlets, but replacement sodding will be required at trenches for pipes stubbed into paved ditches.

In sag vertical curves separate outlet pipes for concrete pavement subdrains from opposite directions shall use a single apron unless otherwise shown in the plans or otherwise directed by the Engineer.

Backfill around outlet pipes shall be of cohesive soils, draincrete will not be permitted.
- Existing paved shoulder that is removed for the construction of outlet pipes shall be replaced with Type SP asphaltic concrete at the rate of 500 LB per SY.
- The contract unit price for Edgedrain Outlet Pipe (4") LF, shall be full compensation for removal of existing shoulder pavement, trench excavation, pipe and fitting, concrete apron, hardware cloth, sod, stubbing into existing inlets and paved ditches, restoration of ditch pavement, backfill in place, and disposal of excess materials.

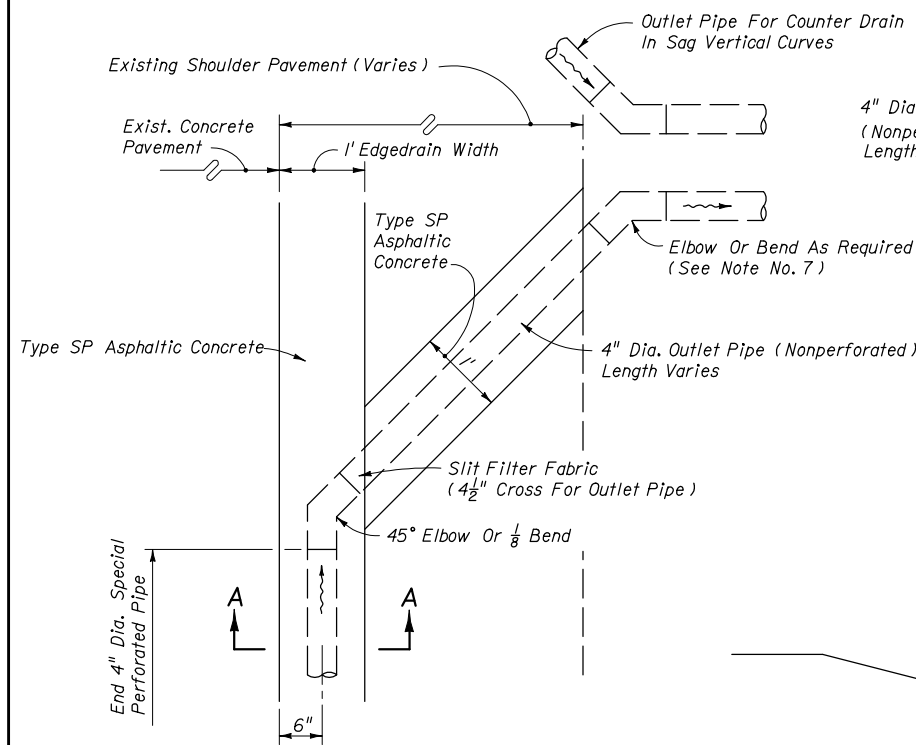

ALIGNMENT OF OUTLET PIPE

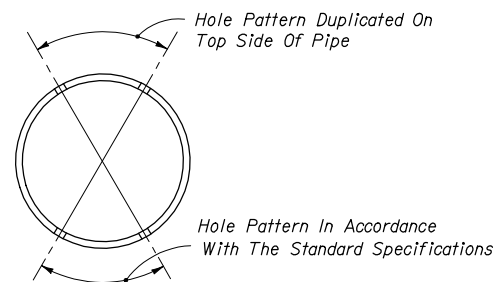

**HOLE PATTERN
SUBDRAINAGE PIPE**

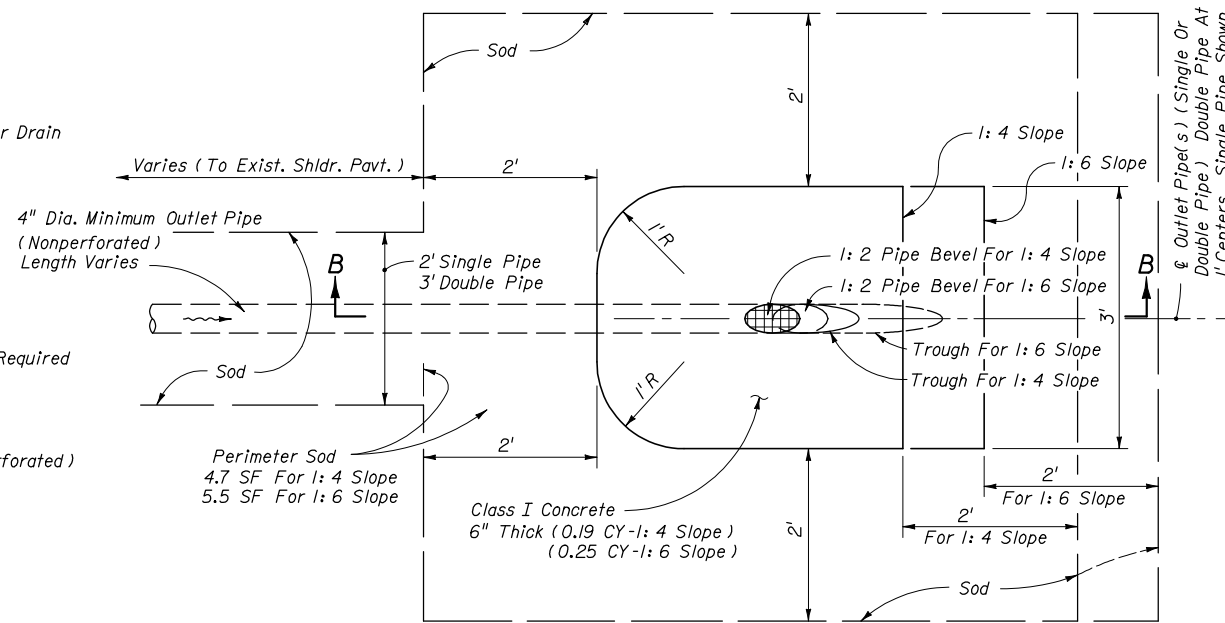

PLAN - OUTLET PIPE APRON

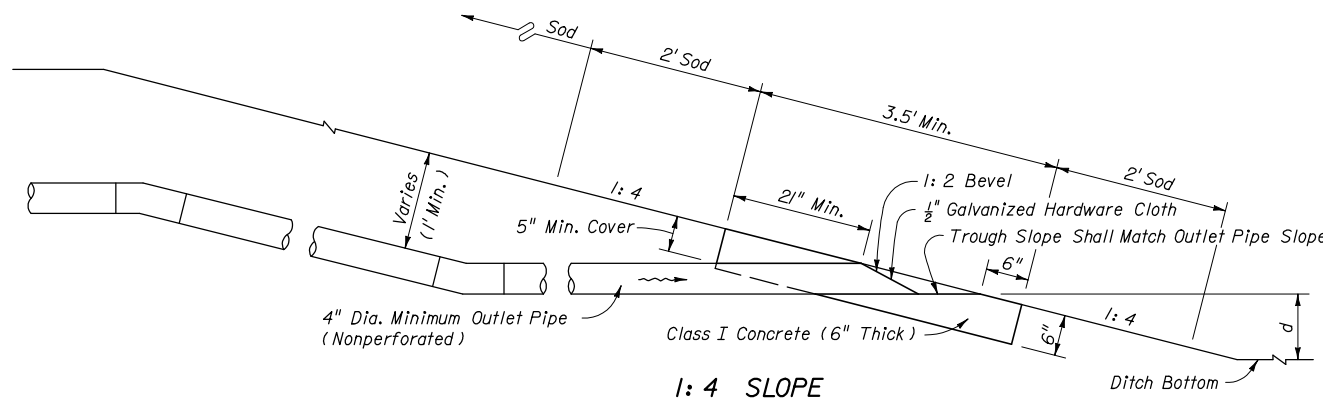

1:4 SLOPE

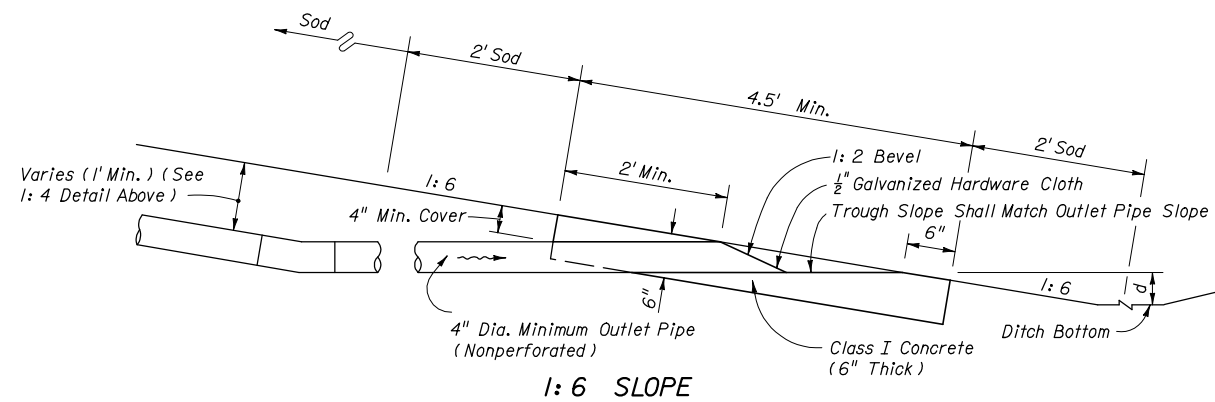

1:6 SLOPE

4\"/>

$d = 1.75'$ std. for grassed ditches [less is acceptable to provide minimum 0.1% outlet pipe slope]
 $0.5'$ std. for paved ditches

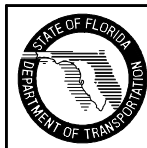

2008 FDOT Design Standards

CONCRETE PAVEMENT SUBDRAINAGE

Last Revision	Sheet No.
07/01/05	1 of 3
Index No.	
287	

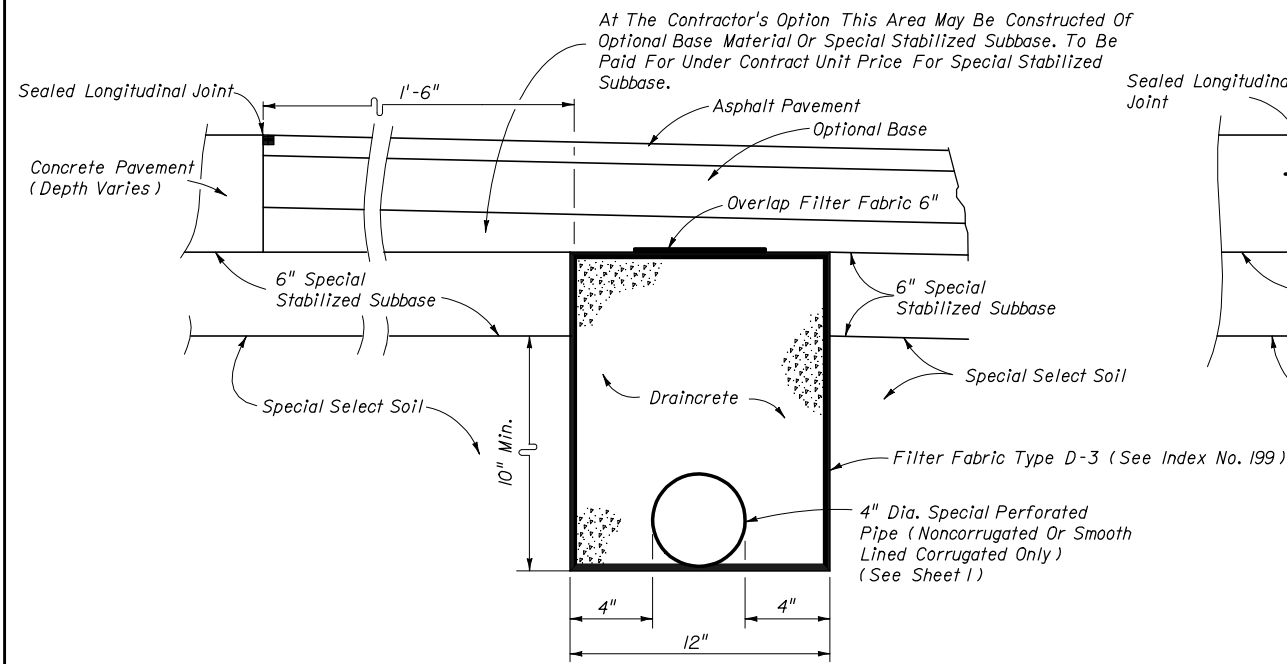

ASPHALT SHOULDERS

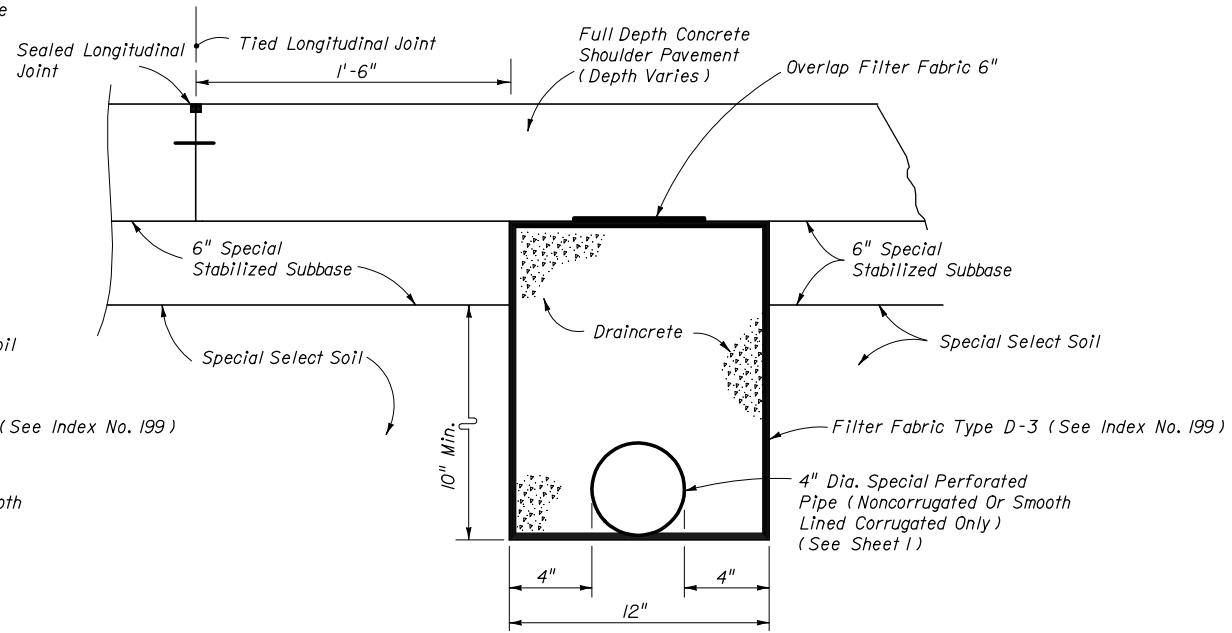

CONCRETE TRAVEL LANES, SHOULDERS, AND AUXILIARY PAVEMENT

NEW CONSTRUCTION

NOTES FOR DRAINCRETE PAVEMENT SUBDRAINAGE

1. The edgedrain sections for DRAINCRETE SUBDRAINAGE are applicable to pavement construction identified as RIGID PAVEMENT on Index No. 505, Sheet 2 and 3.
2. The contractor shall confine the construction of draincrete edgedrain to an area in which the entire operation can be carried out in five (5) work days, unless another construction period is called for in the plans, with sufficient time allowed for the draincrete to set before placement of pavement.

METHOD OF PAYMENT

NEW CONSTRUCTION:

1. The contract unit price for Edgedrain (Draincrete) LF shall be full compensation for trench excavation, disposal of excess material, filter fabric, draincrete edgedrain pipe and fittings and draincrete.
- Payment for outlet pipe shall be in accordance with General Note 9, Sheet 1 of 3.

FOR REHABILITATION:

1. The contract unit price for Edgedrain (Draincrete) LF, shall be full compensation for removal of existing shoulder pavement, trench excavation, disposal of excess materials, filter fabric, draincrete edgedrain pipe and fittings, and draincrete, necessary for edgedrain construction.
- Payment for outlet pipe shall be in accordance with General Note 9, Sheet 1 of 3.
- Shoulder pavement shall be paid for under the contract unit price for Type SP, Asphaltic Concrete.
- Shoulder joint seal shall be paid for under the contract unit price for Pavement Joint, LF.

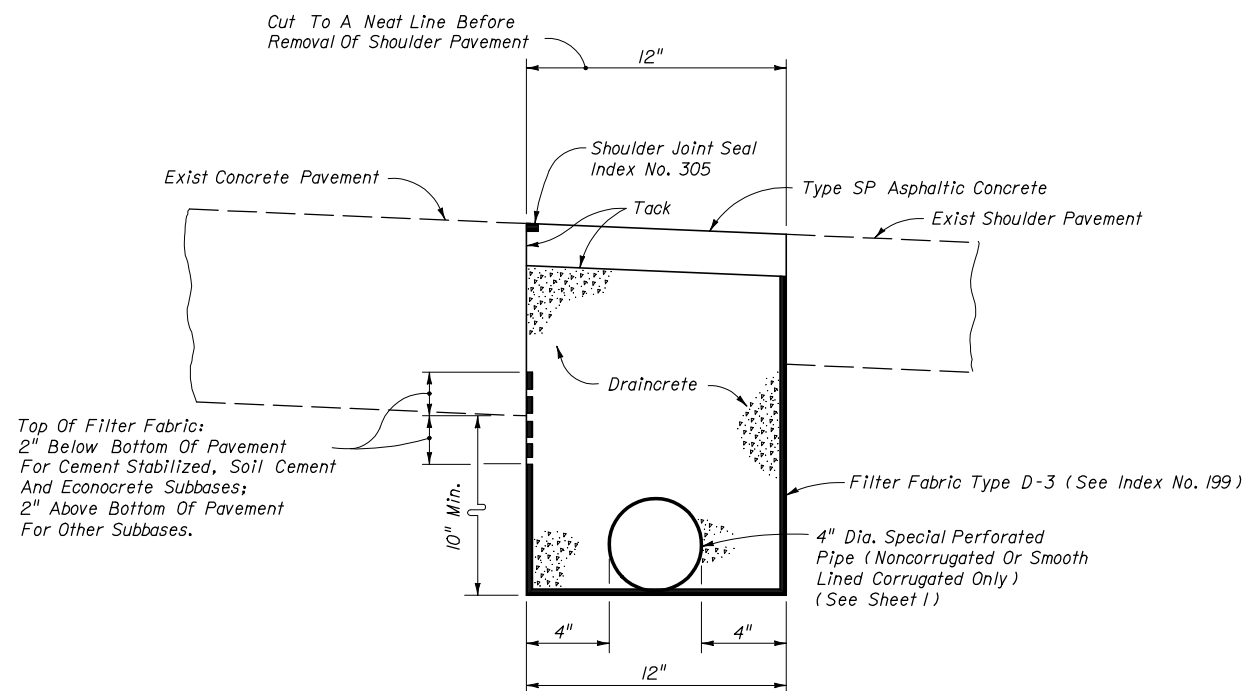

REHABILITATION

DRAINCRETE SUBDRAINAGE



2008 FDOT Design Standards

CONCRETE PAVEMENT SUBDRAINAGE

Last Revision	Sheet No.
07/01/07	2 of 3
Index No.	
287	

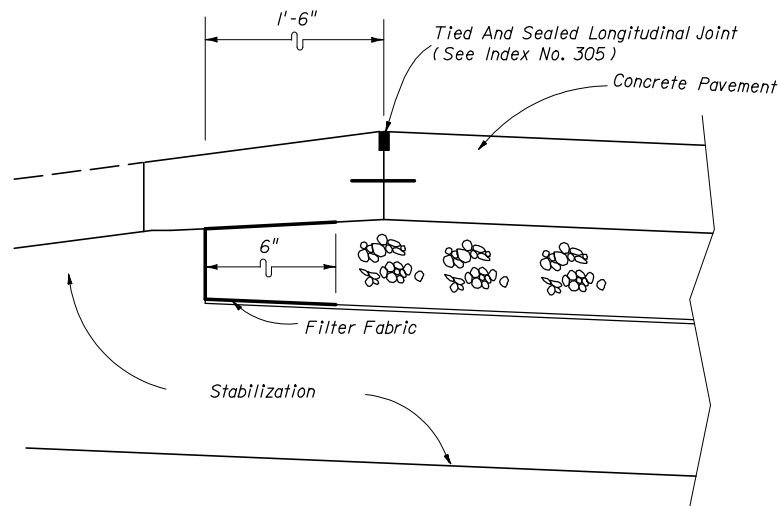

CONCRETE TRAVEL LANE, SHOULDERS, AND AUXILIARY PAVEMENT

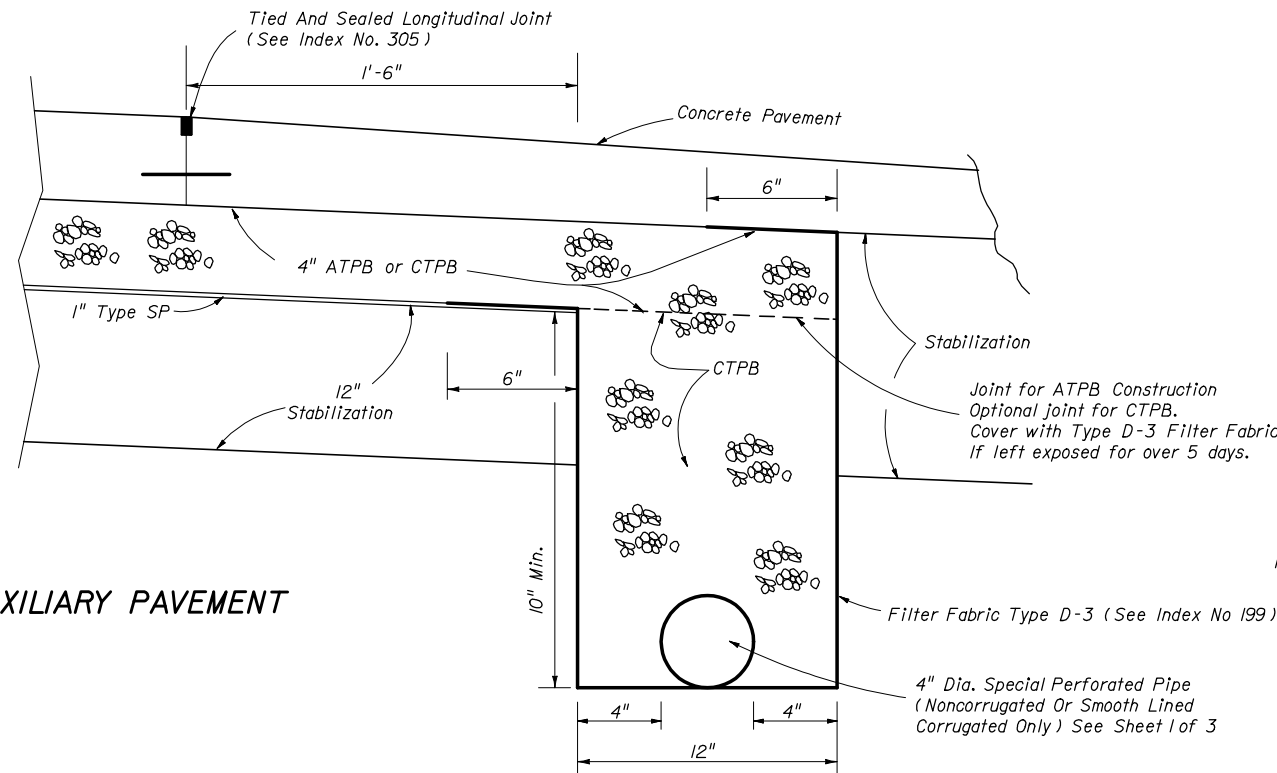

GENERAL NOTES FOR TREATED PERMEABLE BASE EDGEDRAIN
(NEW CONSTRUCTION)

- The contractor shall confine the construction of edgedrain to an area in which the entire operation can be carried out in (5) work days, unless another construction period is called for the plans.

METHOD OF PAYMENT

NEW CONSTRUCTION

- Payment shall be full compensation for trench excavation, disposal of excess materials, filter fabric, pipe and fittings, necessary for concrete pavement subdrainage construction. Payment shall be included in the cost for Asphalt Treated Permeable Base, CY or Cement Treated Permeable Base, CY.

Payment for outlet pipe shall be in accordance with General Note 9, Sheet 1 of 3.

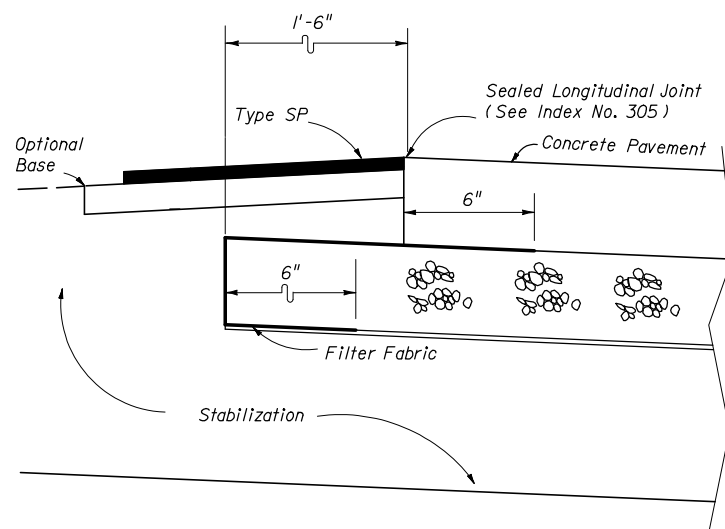

ASPHALT SHOULDERS

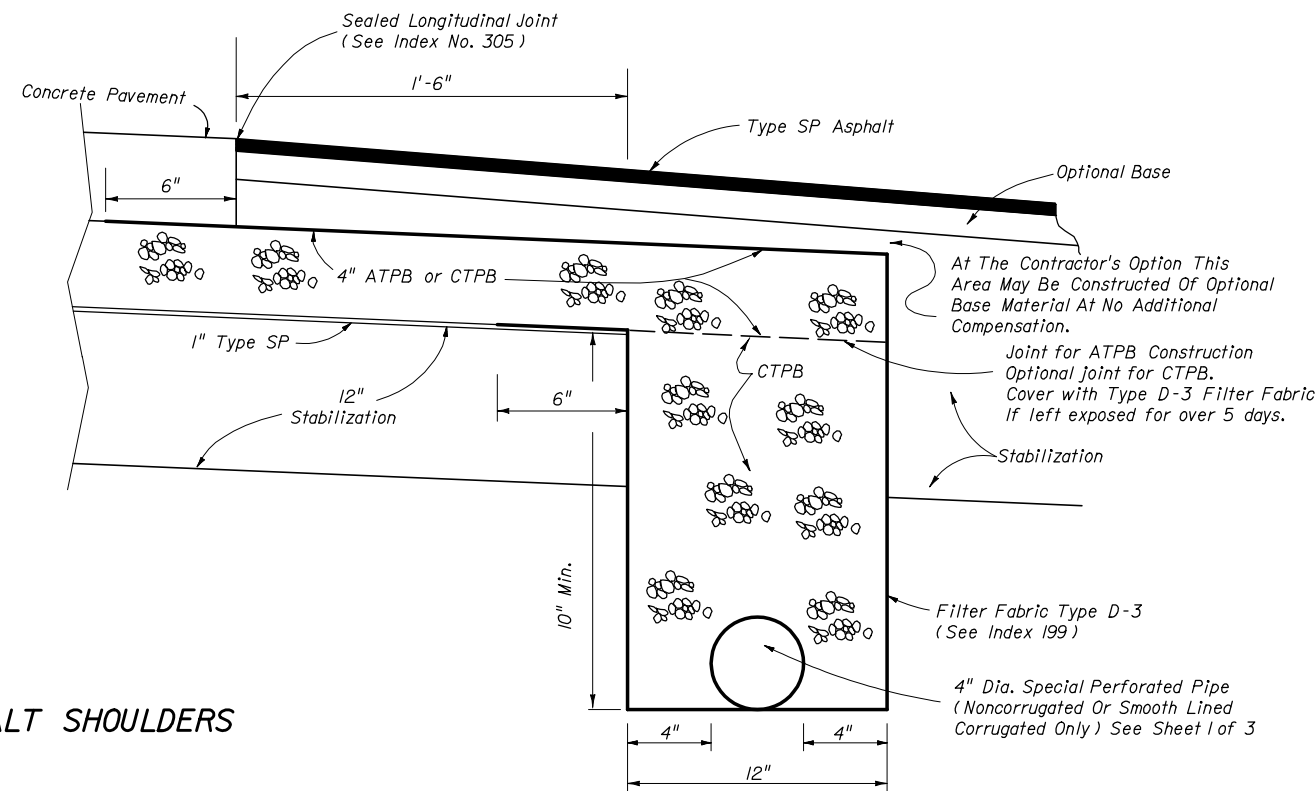

Not To Scale

