

SECTION BB

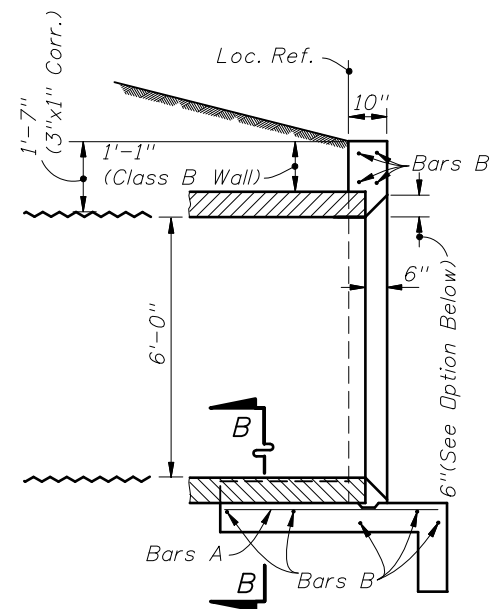

SECTION AA

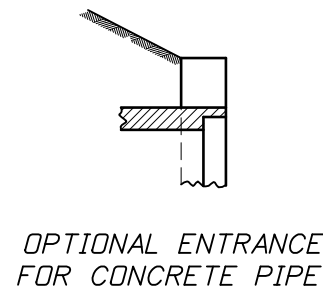

OPTIONAL ENTRANCE FOR CONCRETE PIPE

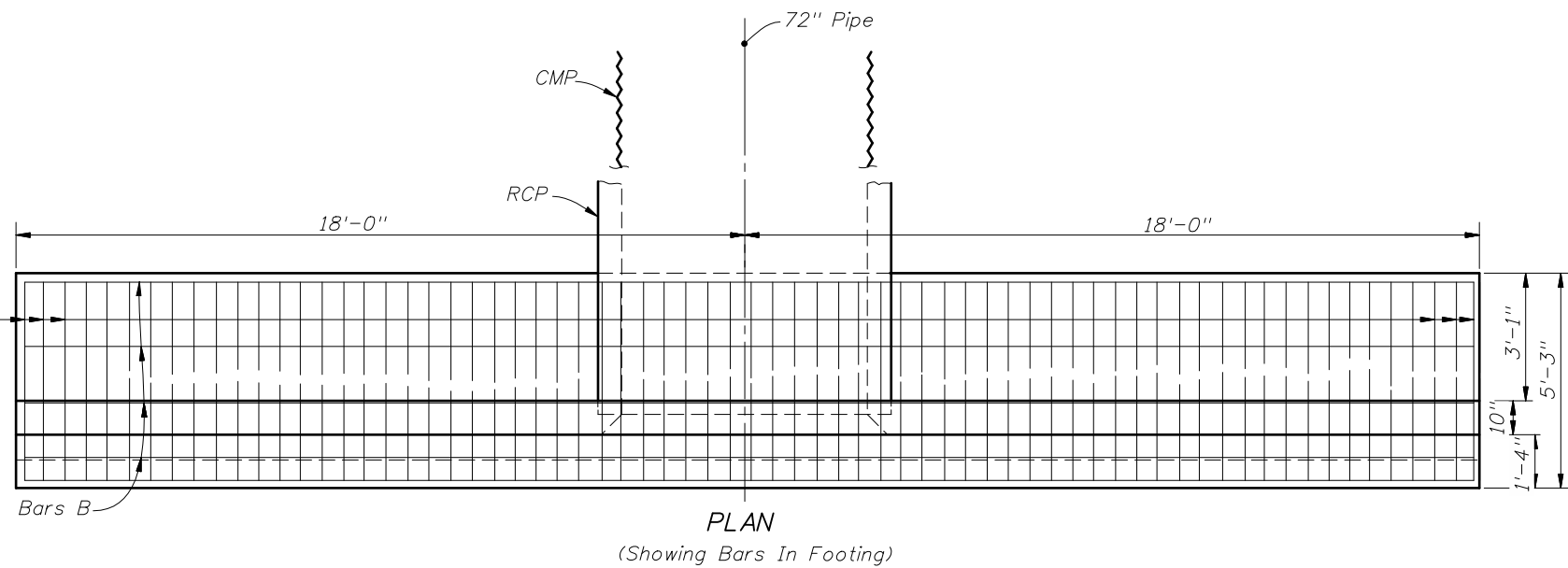

PLAN
(Showing Bars In Footing)

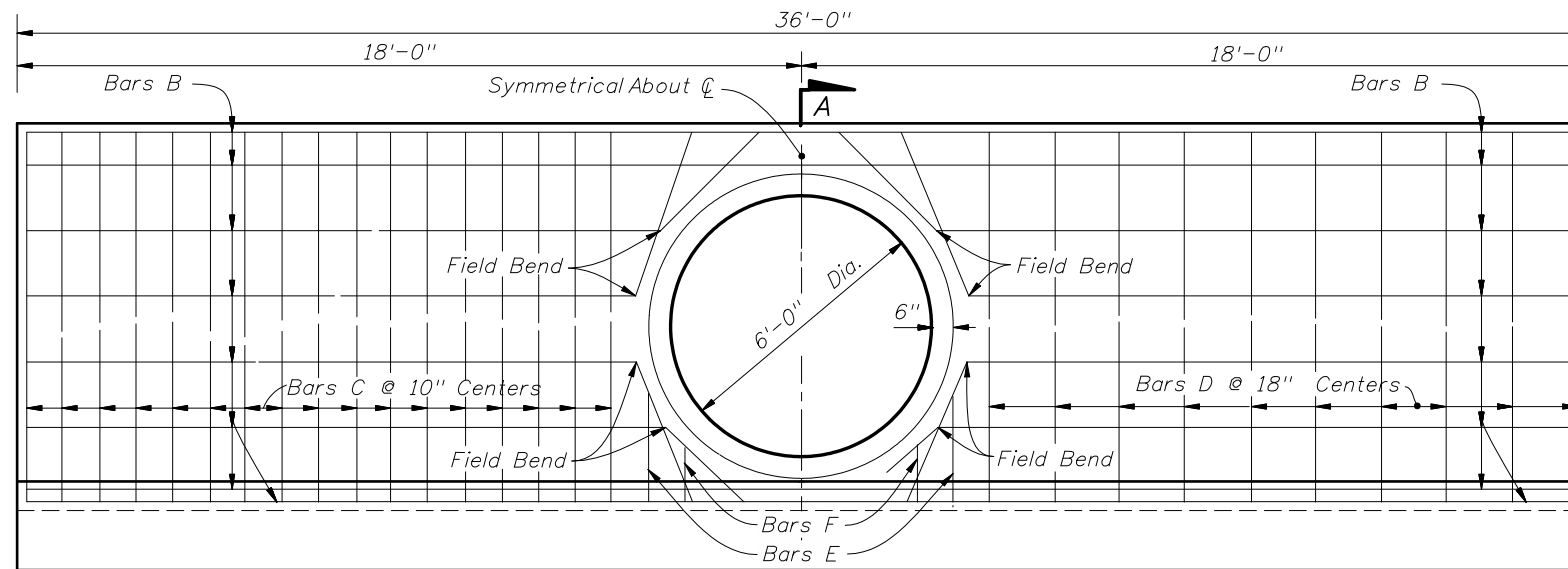

HALF ELEVATION
(Showing Bars In Back Face Of Wall)

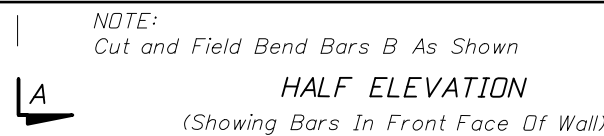

HALF ELEVATION
(Showing Bars In Front Face Of Wall)

GENERAL NOTES

1. Straight concrete endwalls are intended for use outside the clear zone.
2. Endwalls may be cast-in-place or precast construction. Cast-in-place endwalls shall conform to the details on this index, design specifications AASHTO 1989. Precast construction which adheres to this Index, including any additional reinforcement required for handling which shall be determined by the Contractor or supplier, does not require additional approvals. Deviations from this Index, for precast units, shall require the approval of the State Drainage Engineer prior to construction. For precast construction, see Index No. 201 for opening and grouting details.
3. Reinforcing steel shall be either Grade 40 or 60.
4. Concrete shall be Class II except concrete meeting the requirements of ASTM C 478 (4000 PSI) may be used in lieu of Class II concrete in precast units manufactured in plants which are under the Standard Operating Procedures for the inspection of precast drainage products.
5. Chamfer: All exposed edges and corners to be chamfered $\frac{3}{4}$ " unless otherwise shown.
6. That portion of corrugated Metal pipe in direct contact with the concrete slab and extending 12" beyond shall have a continuous bituminous coating of 0.004" minimum thickness coated applied prior to placing of the concrete.
7. Sodding shall be in accordance with Index No. 281 and paid for under the contract unit price for Performance Turf, SY.
8. Basis of payment for either cast-in-place or precast construction shall be the estimated quantities tabulated on the Index. Concrete and reinforcing steel shall be paid for under the contract unit prices for Class II Concrete (Endwalls), CY and Reinforcing Steel (Roadway), LB.

BILL OF REINFORCING STEEL					
MARK	SIZE	NO. REQD.	LENGTH	LOCATION	BENDING
A	5	68	4'-11"	Footing	Straight
B	4	17	35'-8"	Footing & Wall	Straight
C	5	34	10'-5"	Wall	Bend
D	4	20	8'-7"	Wall	Straight
E	4	4	2'-6"	Wall	Straight
F	4	4	1'-6"	Wall	Straight

BENDING DIAGRAM

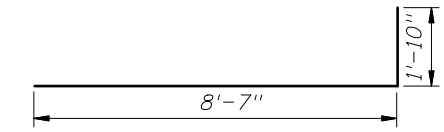

BAR C
NOTE: All bar dimensions are out to out

ESTIMATED QUANTITIES

ITEM	UNIT	RCP	CMP
Class II Concrete	Cu. Yd.	14.4	14.5
Reinforcing Steel	Lb.	1249	1249

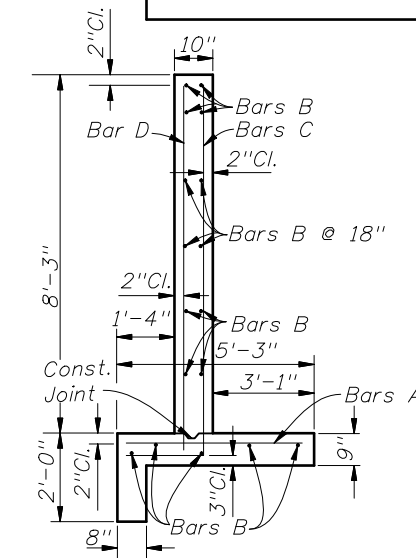

TYPICAL SECTION THRU ENDWALL

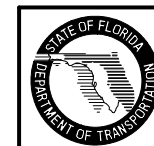

2008 FDOT Design Standards

STRAIGHT CONCRETE ENDWALLS
SINGLE AND DOUBLE 72" PIPE

Last Revision 07/01/07
Sheet No. 1 of 2
Index No. 253

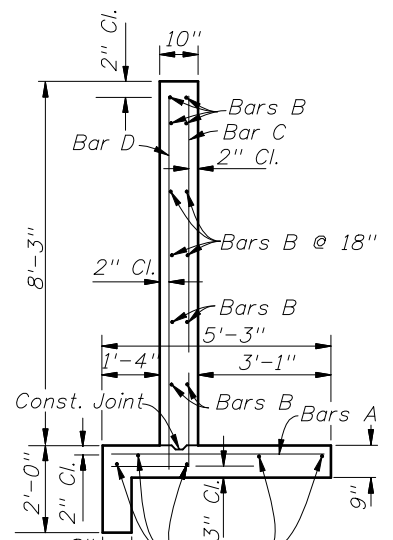
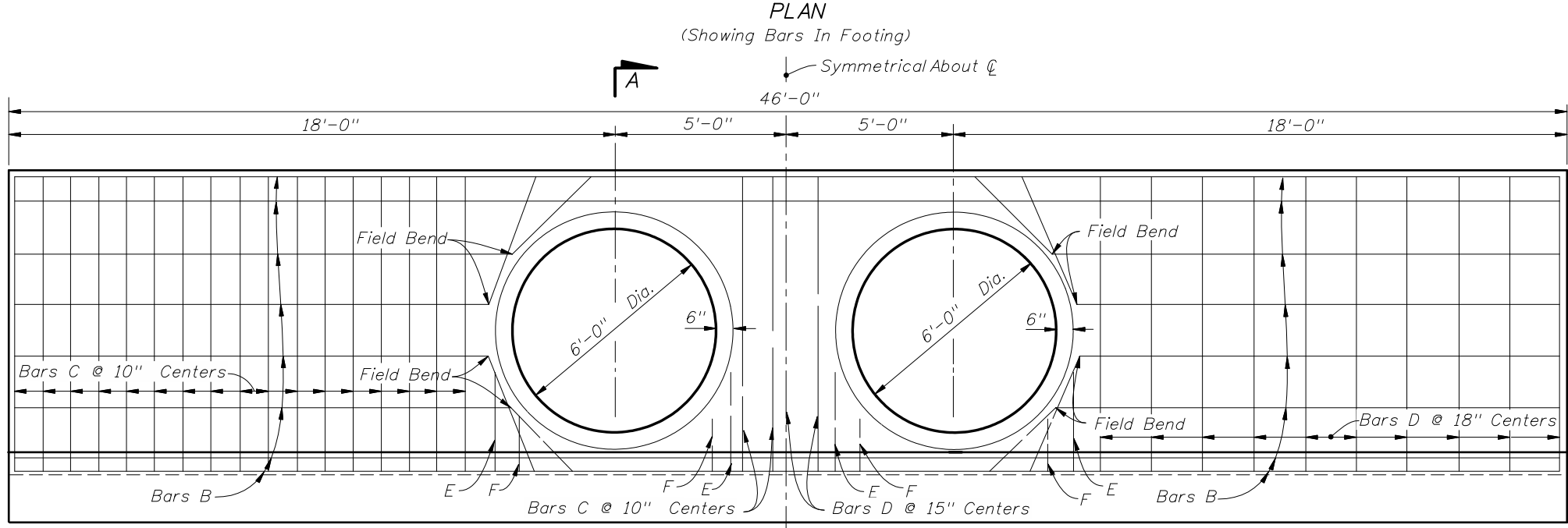
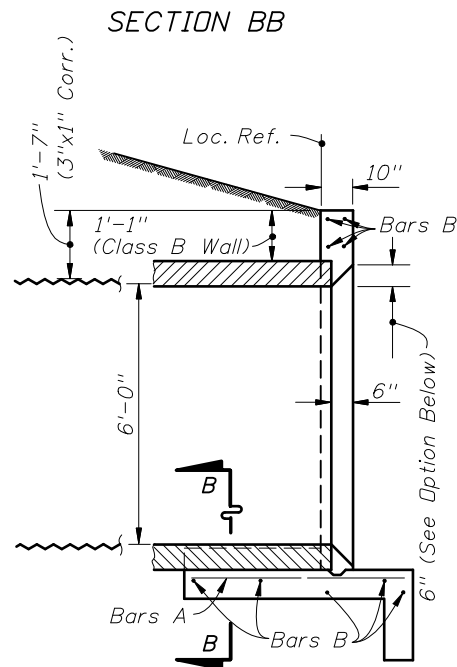
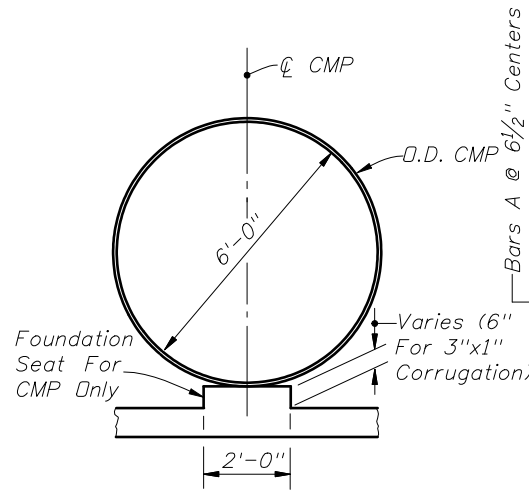
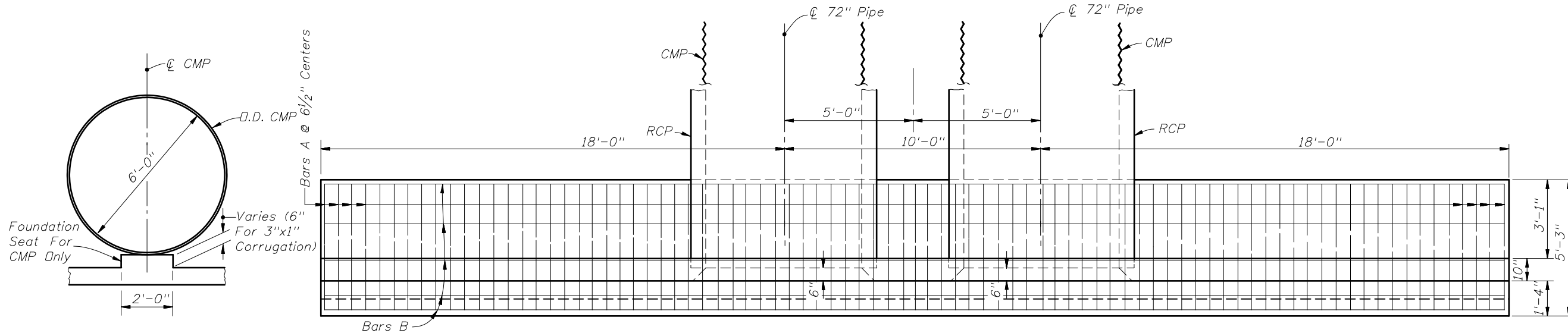

NOTE: Cut and Field Bend Bars B As Shown

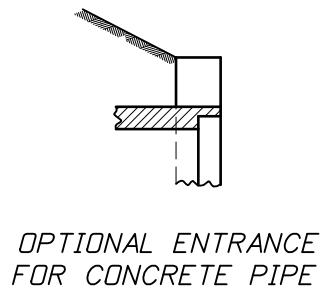

BILL OF REINFORCING STEEL					
MARK	SIZE	NO. REQD.	LENGTH	LOCATION	BENDING
A	5	85	4'-11"	Footing	Straight
B	4	17	45'-8"	Footing & Wall	Straight
C	5	38	10'-5"	Wall	Bend
D	4	23	8'-7"	Wall	Straight
E	4	8	2'-6"	Wall	Straight
F	4	8	1'-6"	Wall	Straight

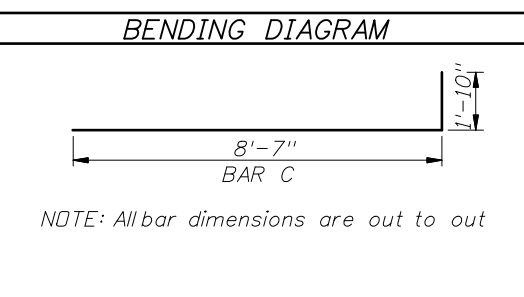

ESTIMATED QUANTITIES			
ITEM	UNIT	RCP	CMP
Concrete Class II	Cu. Yd.	17.5	17.8
Reinforcing Steel	Lb.	1519	1519

NOTE: See Sheet 1 of 2 for General Notes.



2008 FDOT Design Standards
STRAIGHT CONCRETE ENDWALLS
SINGLE AND DOUBLE 72" PIPE

Last Revision: 07/01/07
 Sheet No. 2 of 2
 Index No. 253