

**ESTIMATED QUANTITIES
For Informational Purposes Only**

SLOT TYPE	PAVEMENT		SDD
	SY	CY	SY
Single Slot	6.2	0.9	14
Double Slot	8.1	1.1	19

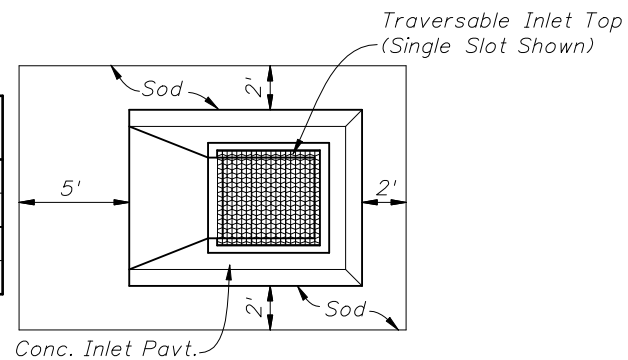

CONCRETE INLET PAVEMENT AND SODDING

NOTE: Alt. B Structure Bottom Only. See Index No. 200 for structure bottom details and pipe opening reinforcement.
INLET WITH STRUCTURE BOTTOM

RECOMMENDED MAXIMUM PIPE SIZES

INLET INSIDE WIDTH	PIPE SIZE
3'-8"	30"
4'-2"	36"

Note: Recommended sizes are for concrete pipe. Sizes for other types of pipe must be verified for fit in accordance with Index No. 201. For larger pipe see bottom detail above and Index No. 200.

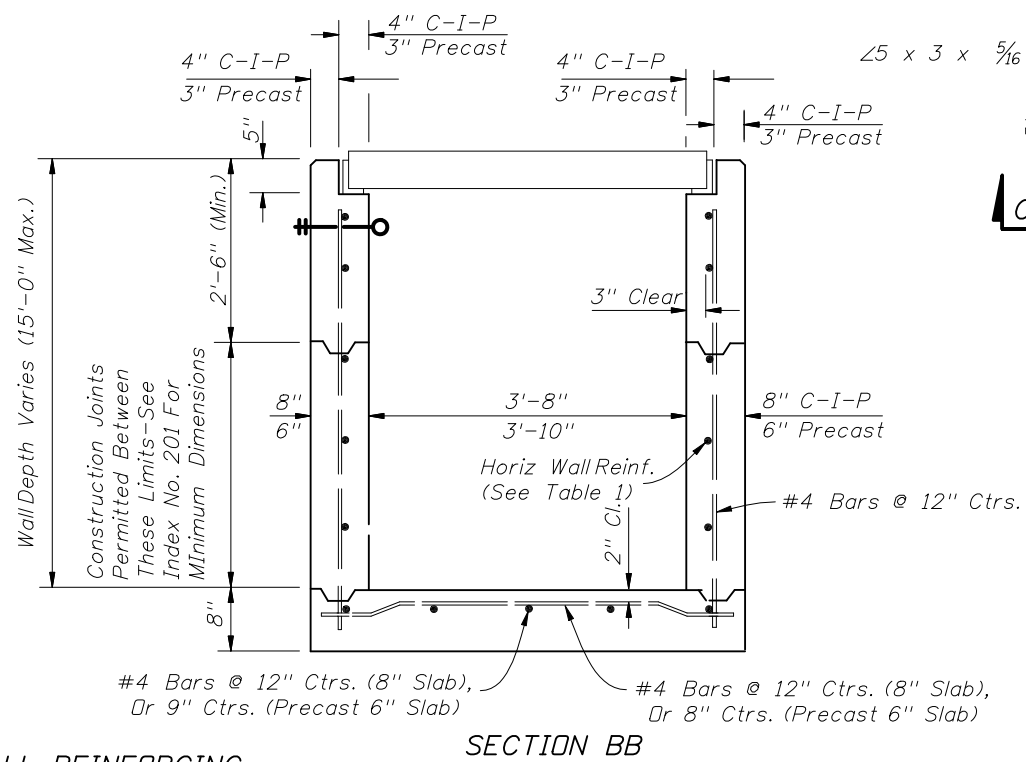
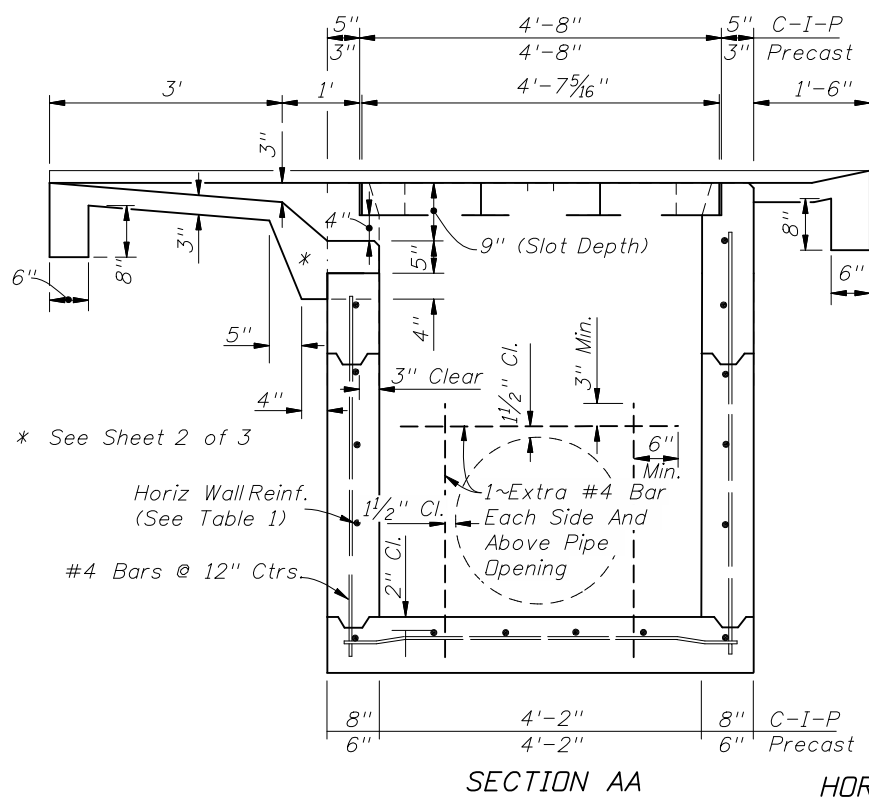

HORIZONTAL WALL REINFORCING SCHEDULE (TABLE 1)

WALL DEPTH	SCHEDULE	AREA (in. ² /ft.)	MAX. SPACING BARS	WWF
0' - 5'	A12	0.20	12"	8"
5' - 9'	A6	0.20	6"	5"
9' - 13'	B5.5	0.24	5 1/2"	5"
13' - 15'	Special	0.267	5"	4"

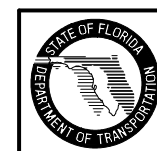
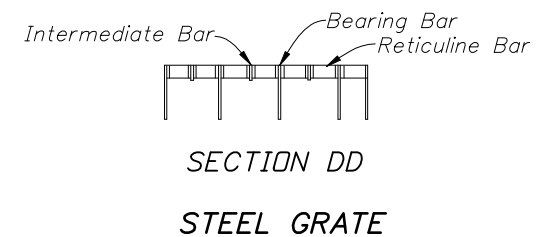
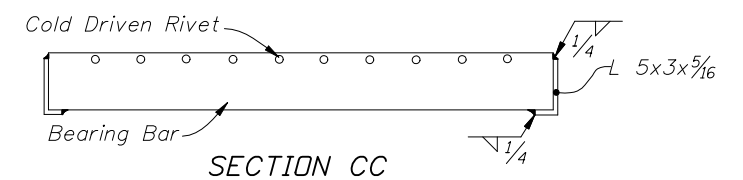
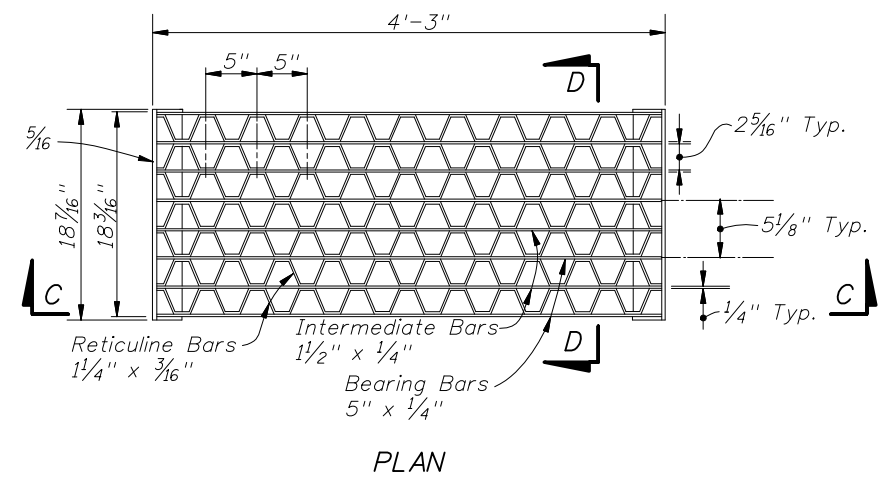

2008 FDOT Design Standards

DITCH BOTTOM INLET TYPE B

Last Revision
07/01/05
Sheet No.
1 of 3
Index No.
231

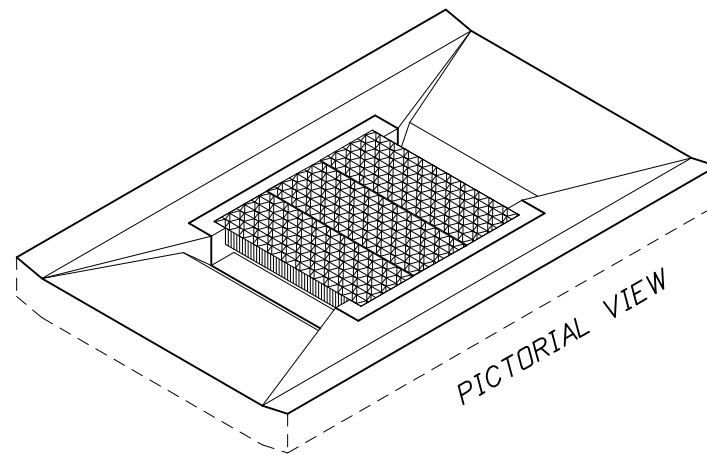
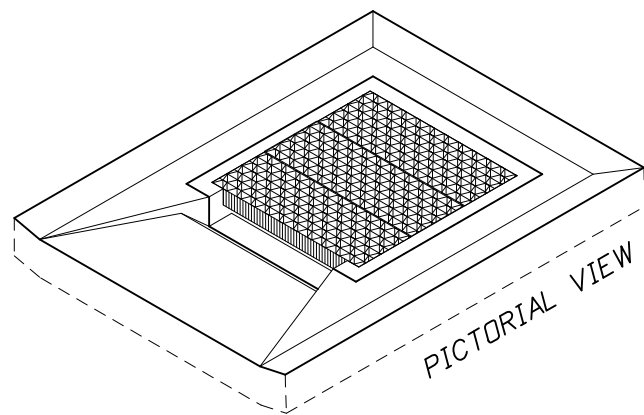

GENERAL NOTES

- The general purpose of the inlet top designs are:
 - For ditches, medians or other areas subject to heavy wheel loads. This inlet may be placed in areas subject to occasional pedestrian traffic such as landscaped areas and pavement areas where pedestrians can walk around the inlet.
 - Provide full grate and horizontal slot designs for new construction.
 - Provide full grate and horizontal slot designs for replacing the vertical slot tops on existing Inlets Type B and Type X that are in locations subject to occasional pedestrian traffic.
- All reinforcing is Grade 60 bars with 2" min. cover unless otherwise noted. See Index No. 201 for equivalent area of welded wire fabric. Bars to be cut or bent for min. 1 1/2" clearanc around pipe.
- All exposed edges and corners shall be 3/4" chamfer or tooled to 1/4" radius.
- When Alternate G grates are specified in the plans, the grates are to be hot-dip galvanized after fabrication.
- Cost for constructing traversable tops on new inlet boxes shall be included in the contract unit price for Inlets (DT BDT) (Type B), EA., and shall include the cost for surrounding concrete inlet pavement. Existing Inlets Type B and Inlets Type X that are converted to traversable inlet tops shall be paid for under the contract unit price for Inlets (DT BDT) (Type B) (Partial), EA. Unit price and payment shall be full compensation for inlet conversion and shall include the removal and disposal of any existing concrete inlet pavement; the removal and stockpiling or disposal of sufficient material from the existing inlet box to facilitate construction of the required inlet top; construction of the required inlet conversion; backfill construction; construction of concrete inlet pavement; reusing, supplementing, transferring or replacing grates as required by plans or as directed by the Engineer; any required earthwork for ditch restoration within 30' of the inlet; and, restoration of disturbed turf.
- Ditch pavement shall be paid for, separate from the inlet and concrete inlet pavement, by pavement types and units as called for in the plans.
- Sod will be paid for under the contract unit price for Performance Turf, SY.
- For supplementary details see Index No. 201.
- All dimensions are for both precast and cast-in-place inlets unless otherwise noted.

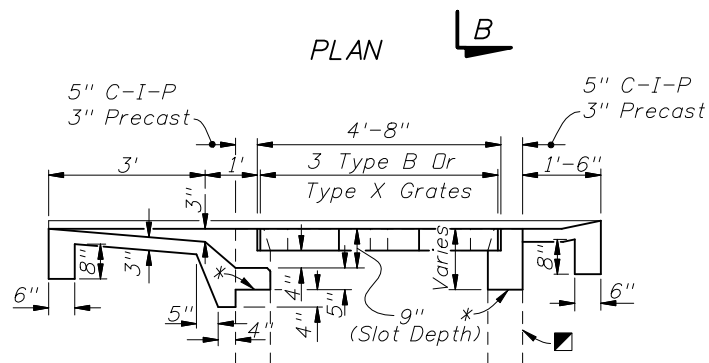
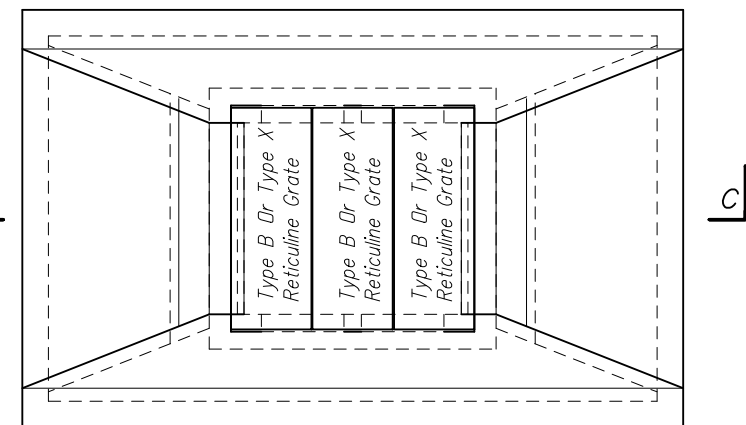
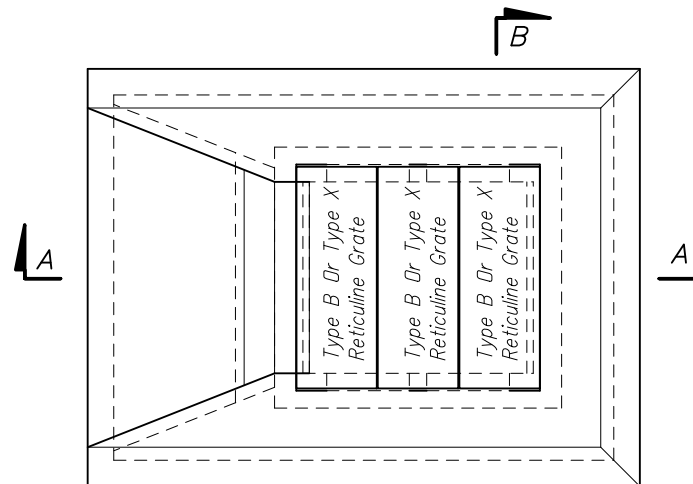

**SECTION AA
SINGLE SLOT**

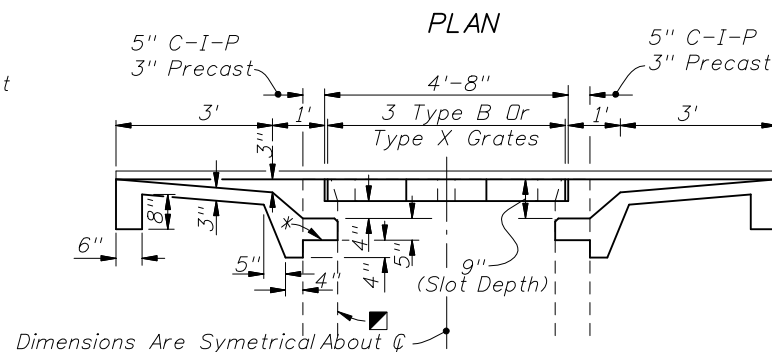

**SECTION CC
DOUBLE SLOT**

■ Inlet Box (Line Type Indicates Existing Box To Facilitate Depiction Of Partial Construction On Existing Inlets)

* On new boxes the traversable top may be cast as a monolithic unit or cast in segments, and the location of this line may be lower to facilitate handling and placement; however, the slot depth is to remain at 9 inches. See Index No. 201 for top to wall connection. For converting to traversable tops on existing inlets remove concrete to this line and expose the existing reinforcement. Reshape or splice in reinforcement to penetrate the rim and returns of the grate seat, and bend the reinforcement into the slot shelf to extend into the abutting throat pavement.

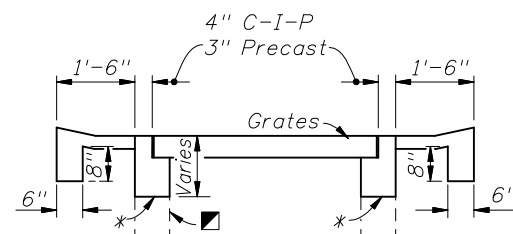

SECTION BB

DESIGN NOTES

- The type of top (single or double slots) depends on the approach ditch configuration and the hydraulic requirements of the site. The designer will stipulate in the plans the type of top to be constructed at each individual inlet location.

On existing inlets, conversion grates shall be constructed at the original grate elevations unless other elevations are called for in the plans. When plans call for the inlet top to be constructed to support storm water detention, details for ditch modifications and underdrains shall be shown in the plans.

MAINTENANCE NOTES

- Traversable inlet tops that are constructed by maintenance contract or by maintenance forces may reuse the existing grates that are determined by the Maintenance Engineer to be functionally sound, and their reuse is so directed by the Maintenance Engineer. Existing grates approved for reuse and new grates may be mixed, matched or replaced as directed by the Maintenance Engineer.

**TRAVERSABLE TOPS FOR INLETS TYPE B AND
FOR CONVERSIONS OF EXISTING INLETS TYPE B AND TYPE X**



2008 FDOT Design Standards

DITCH BOTTOM INLET TYPE B

Last Revision 07/01/07	Sheet No. 2 of 3
Index No. 231	

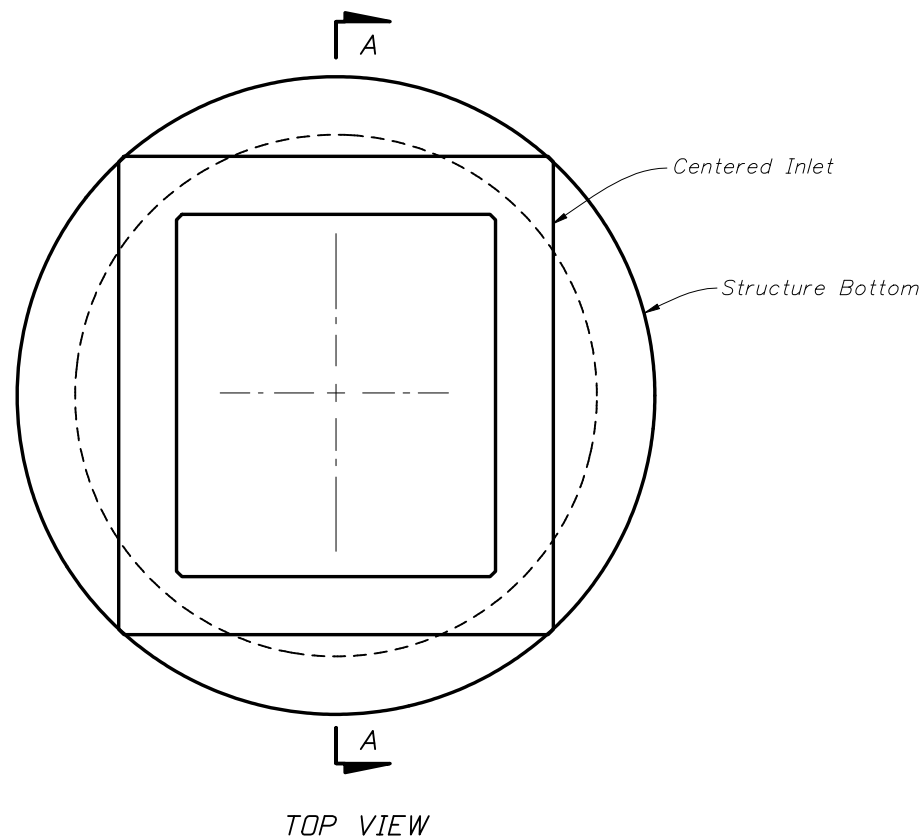

TOP VIEW

TOP SLAB OPENINGS		
DIAMETER	OPENING SIZE	
	MIN.	MAX.
6'-0" to 8'-0"	3'-8" x 4'-2"	3'-10" x 4'-2"

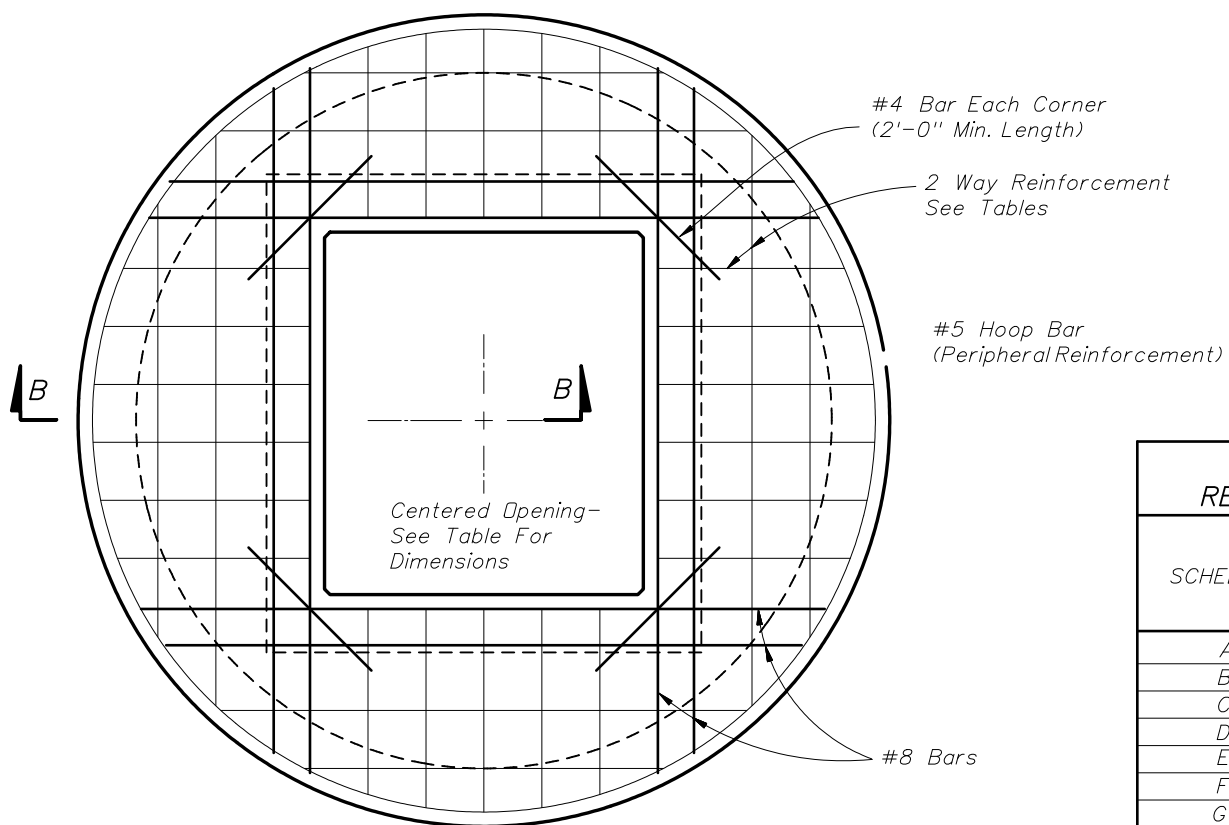

TOP SLAB REINFORCING DIAGRAM

TOP SLAB REINFORCING SCHEDULE	
SCHEDULE	GRADE 60 (BAR) OR 65 KSI & 70 KSI (WIRE FABRIC) $In^2/ft.$
A	0.20
B	0.24
C	0.37
D	0.53
E	0.73
F	1.06
G	1.45

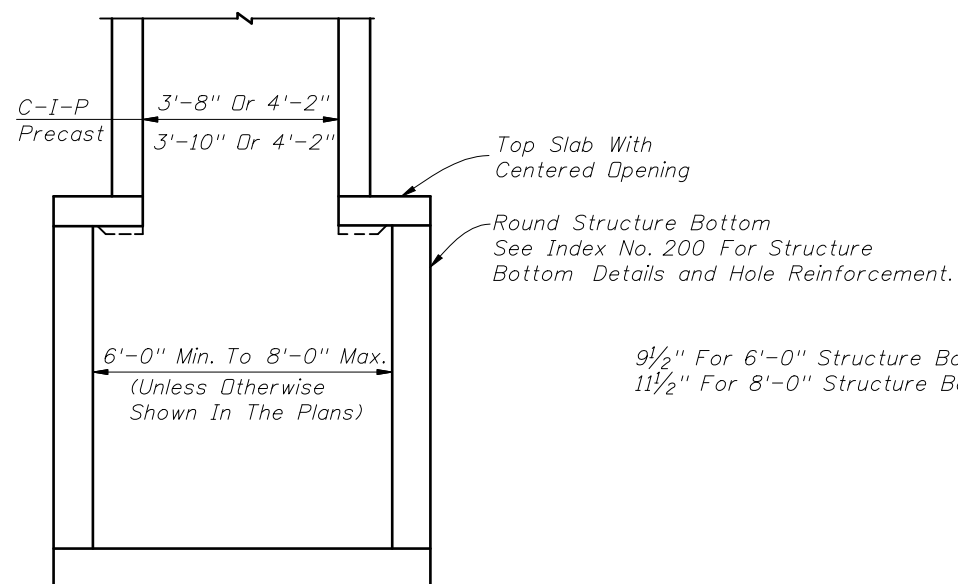

SECTION AA

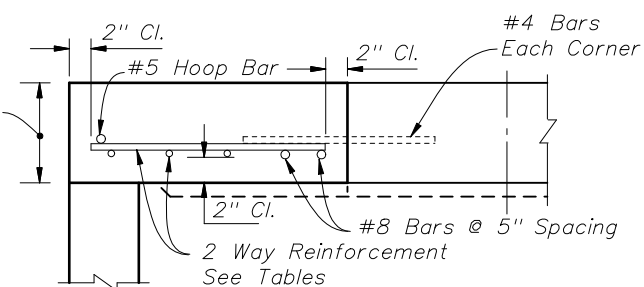

SECTION BB

TOP SLAB WITH CENTERED OPENING		
SLAB DEPTH	SLAB THICKNESS	REINFORCING (2 WAYS) SCHEDULE
SIZE: 6'-0"		
0.5' < 8'	9 1/2"	B
8' < 18'	9 1/2"	C
18' < 30'	9 1/2"	D
30' < 37'	9 1/2"	E
37'-40'	9 1/2"	G
SIZE: 8'-0"		
≥0.5' < 9'	11 1/2"	C
9' < 15'	11 1/2"	D
15' < 23'	11 1/2"	E
23' < 33'	11 1/2"	E
33'-40'	11 1/2"	G

ALT. A STRUCTURE BOTTOM FOR INLET TYPE B

