

TOP VIEW

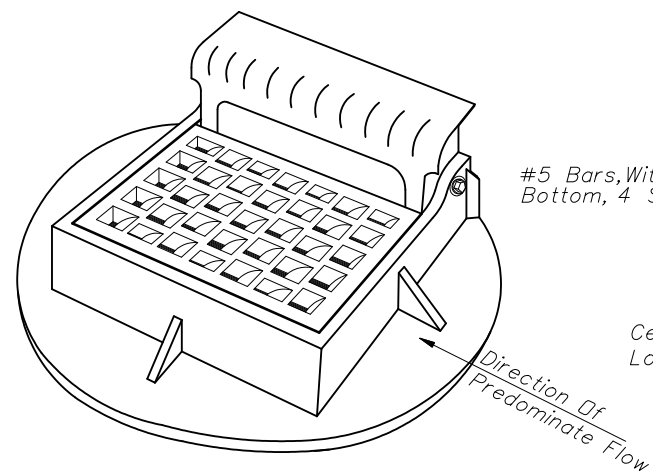

#5 Bars, With Hooks, 4" cc, Bottom, 4 Sides

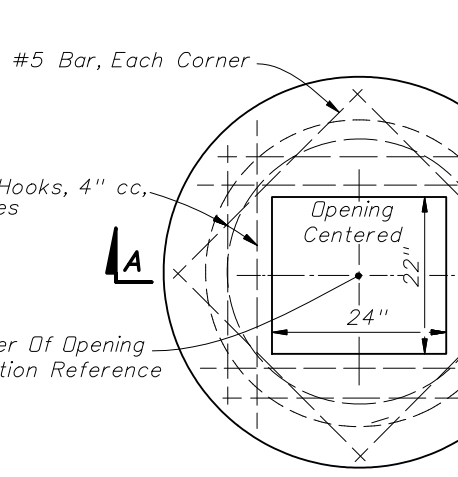

TOP VIEW

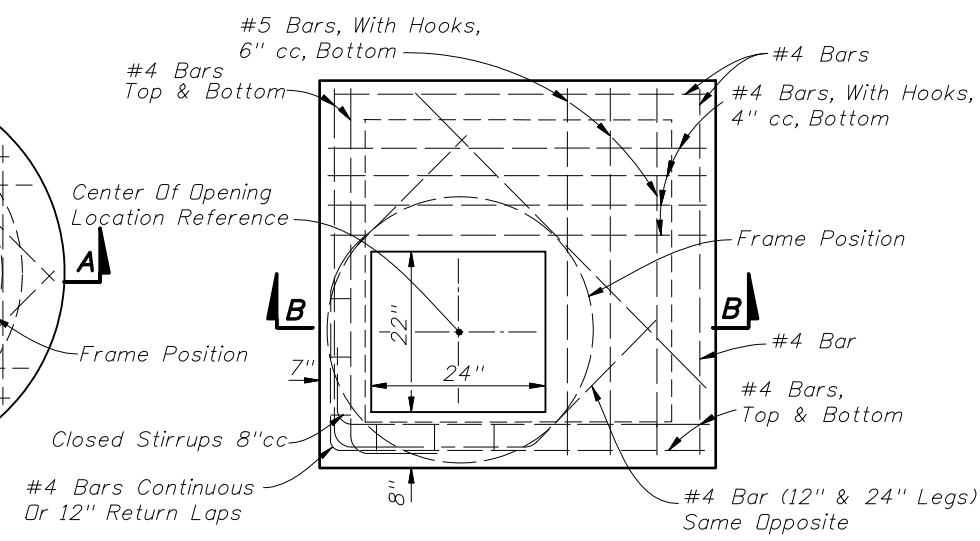

TOP VIEW

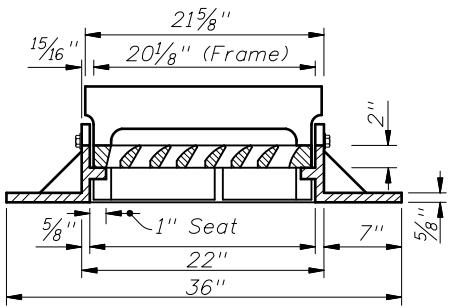

LONGITUDINAL SECTION

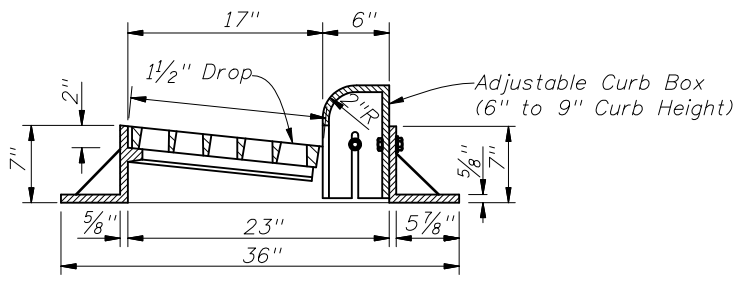

TRANSVERSE SECTION

FRAME AND GRATE

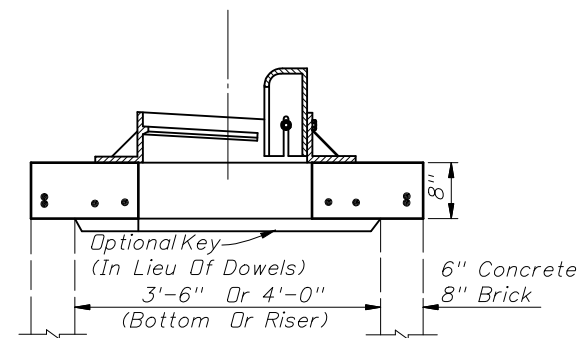

SECTION AA (SEE NOTE 6 BELOW)

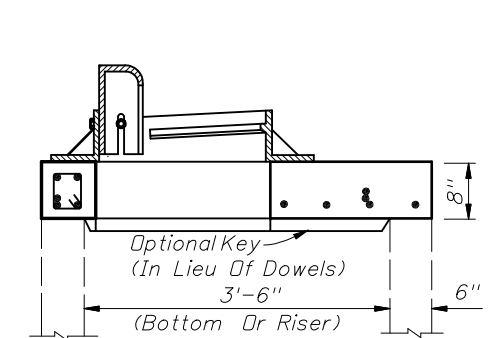

SECTION BB (SEE NOTE 6 BELOW)

TOP SLABS

GENERAL NOTES

1. This inlet is primarily intended for locations with light flows where right of way does not permit the use of throated Curb Inlets Types 1 through 6. The typical application is on curb returns to city streets. The inlet grate is suitable for pedestrian and bicycle traffic.
2. This inlet to be located outside of curb ramp area in vertical faced curbs such as Curb and Gutter Type F. Grate shall be oriented with vanes directed toward predominate flow.
3. For structure bottoms see Index No. 200. For supplemental details see Index No. 201.
4. All steel in slab tops shall have 1 1/4" minimum cover unless otherwise shown. Tops shall be either cast-in-place or precast concrete.
5. For Alternate B applications, top slab openings shall be placed such that 2 edges of inlet frame will be located directly above bottom or riser walls.
6. When used on a structure with dimensions larger than those detail above and risers are not applied, the top slab shall be constructed using Index No. 200 with the slab opening adjusted to 24"x36". The "Special Top Slab" on Index No. 200 is not permitted.
7. Frame may be adjusted with one to six courses of brick.
8. Cast iron frame grate and hood to be U.S. Foundry 5161-6019, Neenah Foundry R-3065-L, or approved equal. Inlet and grate detail shown is Neenah R-3065-L. Vaned grates with approximately equal openings will be permitted that satisfy AASHTD HS-20 loading. Grates shall be reversible.

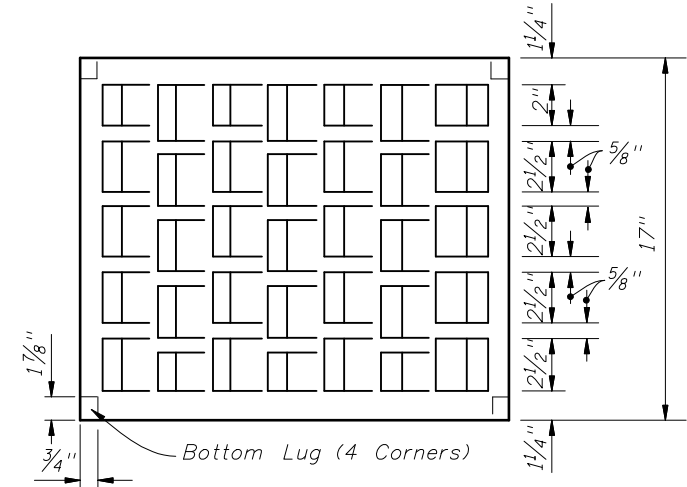

PLAN

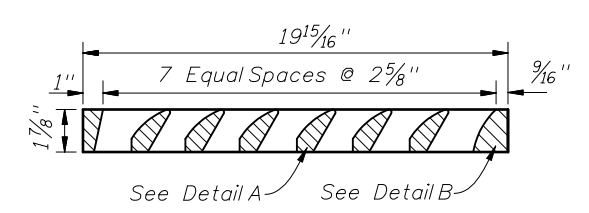

SECTION

GRATE DETAIL

Approximate Debris Free Capacity (0.02 Pavement Cross Slope)

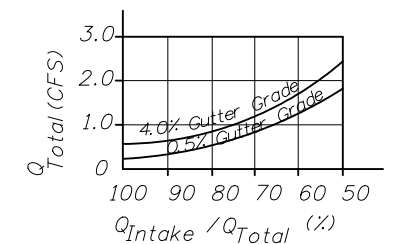

EFFICIENCY CURVE

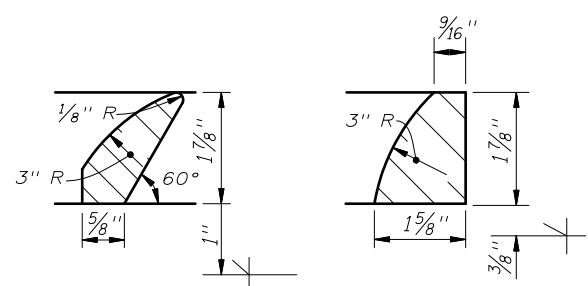

DETAIL A

DETAIL B



2008 FDOT Design Standards

CURB INLET TOP TYPE 10

Last Revision 04 Sheet No. 1 of 1

Index No. 215